

# KENWOOD R-5000 USER HANDBOOK MANUAL



## Quick Links

[Introduction](#)

[Performing Modifications](#)

[Am Broadcast Sensitivity](#)

[If Filters](#)

[DC Power Cable Kit](#)

[Vhf Converter](#)

## Table of Contents

[Table of Contents](#)

[PERFORMING MODIFICATIONS](#)

[CARRIER SCAN vs. TIME SCAN](#)

[EXTENDED FUNCTIONS](#)

[AM BROADCAST SENSITIVITY](#)

[SCAN SPEED](#)

[SCAN RESUME](#)

[BEEP LEVEL](#)

[FILTER TYPES](#)

[INSTALLING FILTERS](#)

[EXTERNAL SPEAKER](#)

[DC POWER CABLE KIT](#)

[VOICE SYNTHESIS UNIT](#)

[VHF CONVERTER](#)

[LEVEL CONVERTER](#)

[REMOTE CONTROL SOFTWARE](#)

[REMOTE INTERFACE INFORMATION](#)

[REMOTE CONTROL COMMANDS](#)

[Other ManualsLib Projects](#)

# THE KENWOOD R-5000 COMMUNICATIONS RECEIVER USER'S HANDBOOK

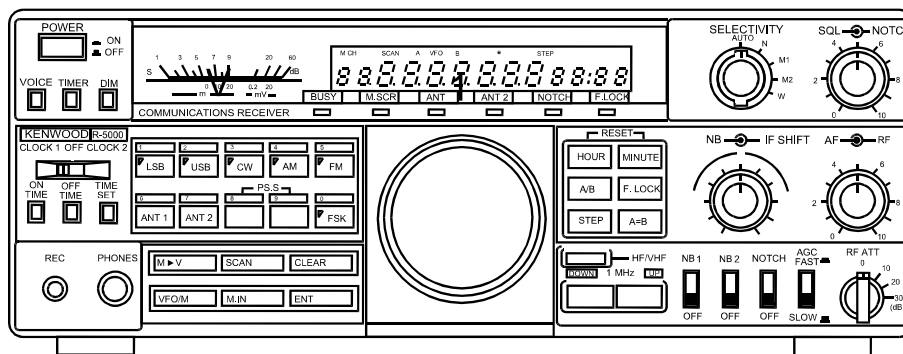

A USER'S GUIDE TO  
MODIFICATIONS, OPTIONS, AND MORE!

by  
David M. Corney  
WB2FCR

# TABLE OF CONTENTS

<b>INTRODUCTION</b> .....	1
<b>MODIFICATIONS</b> - Modifications that enhance radio performance and ease of use.	
PERFORMING MODIFICATIONS.....	2
CARRIER SCAN vs. TIME SCAN.....	2
EXTENDED FUNCTIONS.....	4
AM BROADCAST SENSITIVITY.....	6
<b>ADJUSTMENTS</b> - Internal adjustments that the user can set for personal preferences.	
SCAN SPEED.....	7
SCAN RESUME.....	7
BEEP LEVEL.....	7
<b>OPTIONS</b> - Useful options and how to install them.	
IF FILTERS.....	8
FILTER TYPES.....	8
INSTALLING FILTERS.....	9
EXTERNAL SPEAKER.....	10
DC POWER CABLE KIT.....	10
VOICE SYNTHESIS UNIT.....	11
VHF CONVERTER.....	11
<b>REMOTE CONTROL</b> - How to configure the R-5000 for remote control and how to use it.	
REMOTE CONTROL MODIFICATION.....	12
LEVEL CONVERTER.....	13
REMOTE CONTROL SOFTWARE.....	14
REMOTE INTERFACE INFORMATION.....	14
REMOTE CONTROL COMMANDS.....	15
<b>SERVICE BULLETINS</b> .....	26
<b>APPENDIX A</b> - Addresses of interest.....	27
<b>APPENDIX B</b> - Remote control programs.....	30
<b>APPENDIX C</b> - CMOS handling procedures.....	33

## INTRODUCTION

The Kenwood R-5000 Communications Receiver is truly an advanced high performance radio. It features great sensitivity, dynamic range, high stability and superb interference reduction. It is an all-mode (SSB, AM, FM, FSK) receiver designed to work from 100 kHz to 30 MHz. Coverage of 108 to 174 MHz is possible with the optional VC-20 VHF Converter. The R-5000 also has a 100 channel memory, dual VFOs, selectable IF filters, two noise blankers, and built-in dual clocks.

I have found the radio to be an excellent performer in listening to shortwave broadcasts, utility stations or monitoring any other type of HF transmission. It has excellent audio quality for continuous broadcast listening while the versatile notch filter and noise blankers can make DXing a breeze. With several IF filters to choose from, the user can customize his or her radio to suit their monitoring needs.

This book was written to assist the owners of the R-5000 in enhancing their receivers. I have collected all of the items outlined here over the years I have owned my receiver. Some of the information was easy to find on the World Wide Web, talking to fellow owners, etc, other information was more difficult. I started to compile all this information into one document just for my own personal quick reference book. After it continued to grow, I thought that others could benefit from all this hard work. I just wish someone had done this before to save me the trouble. I hope at least some if not all of this information is useful to you. Happy monitoring!

Dave Corney, WB2FCR

Permission for non-commercial use of this document, in whole form only, is granted. It may be mechanically or electronically copied, stored and/or downloaded provided each of the following conditions are met:

- No charge is made for a copy of this document
- No partial reproductions - the whole document must kept together – especially this page
- Full credit is given to the author

Kenwood is a trademark of Kenwood U.S.A Corporation

Rev A. 1/95 - Changed to Microsoft Word format. Updated KENTROL address

Rev B. 1/98 - Added World Wide Web addresses

Rev C. 2/99 – Word 97 format, updated Appendix B and World Wide Web addresses.

Rev D. 10/03 – Word 2000 format – released to public domain

## MODIFICATIONS

There are several "configurable options" that a user with electronic skills can add/change on the R-5000. These modifications vary in their usefulness, some actually degrade the standard functions. Some are sold by radio dealers as high priced options, but are easily done by the user with a little information. Some of the options that I have found are described in detail below.

### PERFORMING MODIFICATIONS

Most of these modifications involve simply cutting a diode or zero ohm jumper. Zero ohm jumpers look like resistors with no color codes on them. They have no resistance (hence the name zero ohm) but are used to make it easy to make or break continuity between two points in a circuit.

These diodes or jumpers are vertically mounted with one end (the diode's anode end) looping up. This makes enabling and disabling the option easy. To enable a particular option you can cut the loop and move the wires to one side. To disable the option in the future, you can simply re-solder the loop together.

Before you start, first understand that any modifications you do will **void your warranty**. Second the R-5000 has delicate wires and fragile circuit boards, please take care when handling them. Also the receiver has many CMOS parts that very sensitive to static electricity. Use proper CMOS handling procedures. Appendix C has information on CMOS handling.

Please do not attempt any modifications unless you know what you are doing. If in doubt, ask an experienced technician for assistance. The author assumes no liability for the effectiveness or consequences resulting from these modifications.

### CARRIER SCAN vs. TIME SCAN

The R-5000 has a scan function that allows the operator to scan channel groups (Memory Scan) or scan between two designated frequencies (Program Scan). Refer to the instruction manual for details on how both work. The standard scan function is called Time Operated Scan. The operator initiates scanning by rotating the squelch knob until the audio is muted. Then either Memory Scan or Program Scan is started. The radio will stop scanning when squelch is broken by a signal and the busy light comes on. The receiver will automatically return to scan after approximately 5 seconds whether or not the signal is still present.

The R-5000 can be modified for Carrier Operated Scan. This mod allows the receiver to return to scan only after there is no AM or FM signal. This modification involves cutting jumper W64 on the IF board. Figure 1 shows the location of W64.

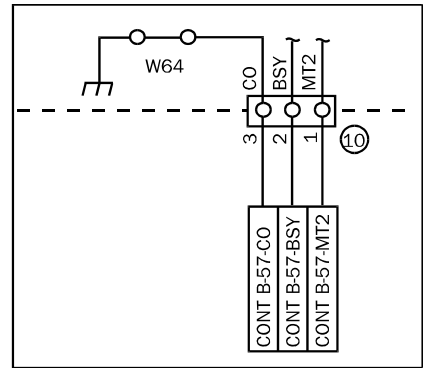
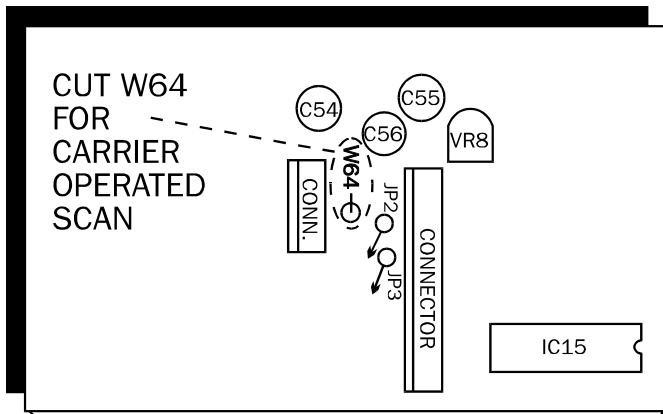

IF UNIT SCHEMATIC

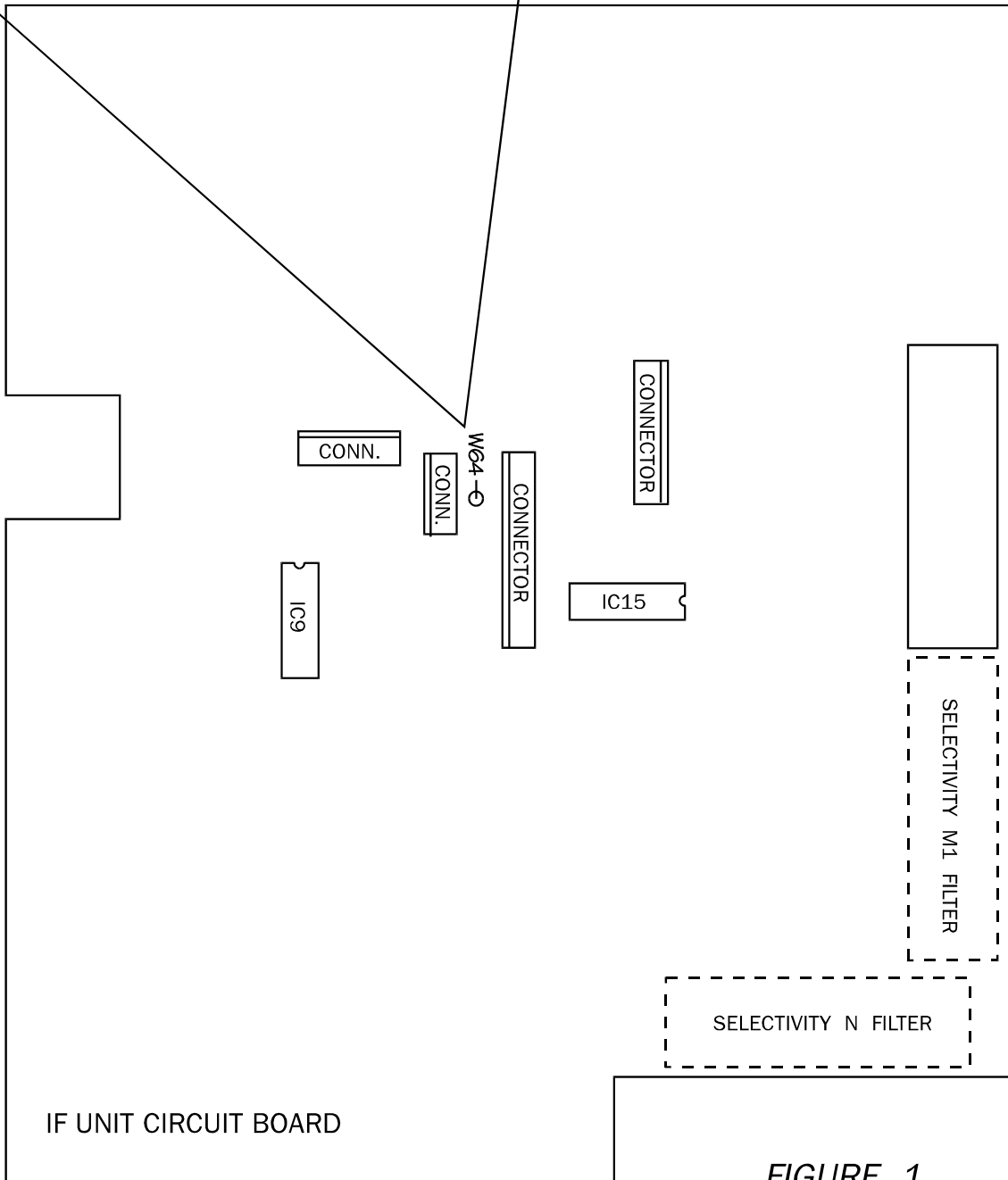

FIGURE 1

When used with the Scan Busy Stop modification (see page 5), this modification makes the scan function in the R-5000 much more effective. Time Operated Scan stops on an active channel only for 5 seconds, then resumes scanning. This means you would miss the rest of the transmission if it last more than 5 seconds. Carrier Operated Scan will not resume scanning until the signal goes away, much like the scanners people use to listen to police and fire calls. With this modification you won't miss a thing!

## EXTENDED FUNCTIONS

The R-5000 has several option jumpers that allow you to change how the receiver functions. These jumpers are vertically mounted diodes located on the Control PWB attached to the front panel. The diodes are labeled D65 to D69 and D72. Figure 2 shows the location of these diodes.

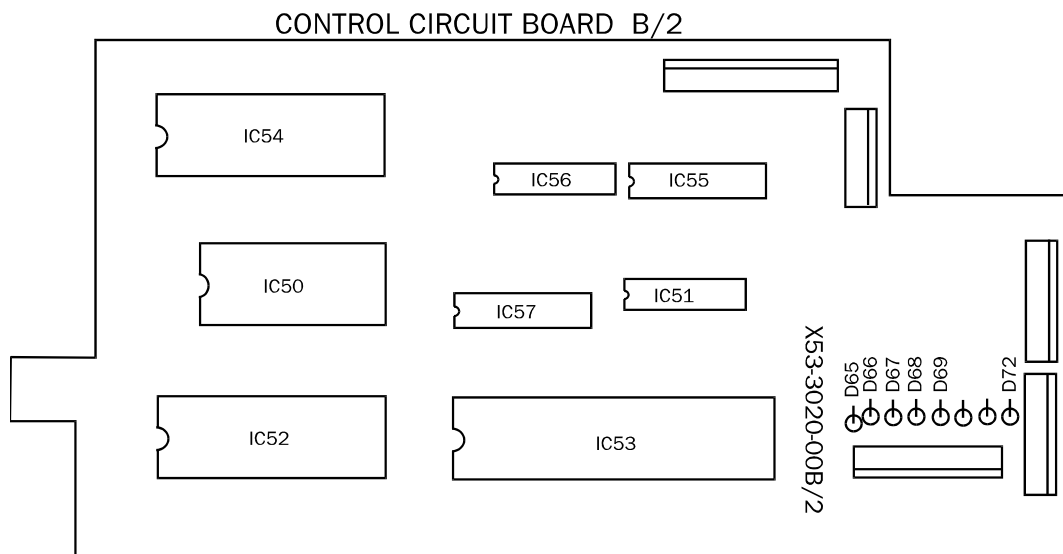

FIGURE 2

### Frequency Resolution

Diode D65 controls the resolution of the frequency display readout. The standard resolution is 10 Hz. With D65 cut, the display resolution is 100 Hz. The receiver still tunes in 10 Hz increments. I don't see any reason to decrease the display resolution, so this option has very limited applications.

### Mode Key Read Back

Diode D66 controls the read-back function of the mode keys. The standard function causes the receiver to generate the Morse code letter corresponding to each mode when a mode key is pressed. Visually impaired operators can then hear which mode they select. With D66 cut, the receiver generates a single beep to acknowledge a mode key press. Most operators get annoyed with the constant beeping, so you can cut this diode and save your sanity. The Adjustment section details how to turn off the beeping completely or adjust the volume level.

### FM Mode Step Frequency

Diode D67 controls the step frequency in FM mode when the step switch is on. The standard step frequency is 2.5 kHz. With D67 cut, the step frequency is 500 Hz. This modification is only for HF-band FM mode. When the VC-20 VHF option is installed, the step frequency is already 500 Hz with the step switch on. There is little FM activity on HF. Unless you know of specific FM transmissions where you need to step in 2.5 kHz increments, this option should be left alone.

### Scan Busy Stop

Diode D68 controls the busy stop in scan mode. The standard scan will stop when the busy light comes on only in AM or FM modes. With D68 cut, the receiver will stop scanning when the busy light comes on in all modes. This allows you to use the scan function in SSB, CW and FSK mode also. Great mod for utility monitoring like military, aircraft, and government agencies. These guys transmit for a short time (10 seconds or less) and you would miss most of the transmission if you try finding them with the tuning knob. You can load up the channels with frequencies and let the receiver scan through them. The radio will stop on the active channels so you can catch the action, and start scanning again when the activity has stopped on that channel.

### Memory Channel Scroll

Diode D69 controls how memory channels are stored and selected depending upon whether you are storing a new channel or stepping through channels already programmed. The standard function allows you to step through all the channels (either empty or programmed) whether you are programming a channel or selecting a channel to monitor. With D69 cut, you can only step through the programmed channels in memory mode and the empty channels are skipped. You will scroll through only those channels with frequencies in them by using the knob or step keys. Also, with D69 cut, when you are programming a channel and have pressed the M.IN key, you can only scroll through the empty channels. The channels already programmed are skipped. This option helps you to manually scroll through the channels faster and makes finding an empty channel to put a new frequency into a whole lot easier.

### Memory Channel Program

Diode D72 controls how channels that are already programmed are overwritten. The standard function allows you to program channels even if they are already programmed. With D72 cut, you cannot program a channel that already has information programmed into it. The only way to erase a channel is to clear the channel as described in the instruction manual. Used with the Memory Channel Scroll above, this option prevents you from overwriting a channel with previously-stored important frequencies. If you program and reprogram channels a lot, this modification is great, but programming the channels using a computer is faster and easier. See the Remote Control section for computer programming tips.

## **AM BROADCAST SENSITIVITY**

The R-5000 has excellent sensitivity in the HF band. The sensitivity in the AM broadcast band is acceptable for most. If you are a hard-core AM broadcast DXer, you can increase the sensitivity in this band slightly. The input filter for this band has an attenuator on its output consisting of R9, R10 and R11. Cutting either R9 or R11 will decrease the amount of attenuation and increase the gain. Be aware that this increase in gain can have a negative effect on strong signal levels in urban areas. A nearby AM broadcaster will have a tendency to overload the front end of the radio, which will result in interference in the receiver. The strong AM broadcast signal will not be properly attenuated and will punch its way through the front end. This interference will block reception of weak signals and the nearby AM broadcast signal could show up all across the band at various intervals blocking other stations.

## **ADJUSTMENTS**

The Kenwood R-5000 has a couple of internal adjustments that the user can set for personal preferences. These are outlined below.

### **SCAN SPEED**

The speed at which the receiver scans between channels or frequencies can be changed. The adjustment for this is a trimmer pot found on the Switch Unit X41-3000-00 A/8 board. This board is located behind the front panel where the squelch knob is mounted. The scan speed can be adjusted using trimmer VR2. If the receiver scans too fast or too slow for your liking try adjusting this trimmer.

### **SCAN RESUME**

The time it takes for the receiver to resume scan can be adjusted. The adjustment for this is another trimmer pot found on the Switch Unit X41-3000-00 A/8 board. This board is located behind the front panel where the squelch knob is mounted. The resume time can be adjusted using trimmer VR3. If the receiver returns to scan too fast or too slow for your liking try adjusting this trimmer.

### **BEEP LEVEL**

The level of the beep sound or mode key read back can be adjusted using VR8 on the IF board. It can set to extremely loud or no beep at all. Note that you can also disable the beep by cutting D9 on the Control PWB, but turning VR8 all the way down is a less destructive method. If the constant beeping of the radio every time you press a button is driving you nuts, try adjusting this trimmer.

## OPTIONS

### IF FILTERS

Adding filters of different bandwidths will help you receive signals in a crowded signal area. The smaller the bandwidth, the less a signal on an adjacent frequency can interfere with your frequency of interest. Every type of signal has a certain bandwidth: usually 4 to 6 kHz for broadcast, 3 kHz for SSB, and 150 Hz for CW. If you use a CW filter of 500 Hz to receive a broadcast station with 6 kHz bandwidth you will be cutting off most of the signal - not a good idea. A 1.8 kHz filter will work great in SSB mode because it is just wide enough to let one signal through while filtering out adjacent signals. Adding filters will improve your ability to reject adjacent interfering signals and pull in those weak ones.

The R-5000 will accept up to four filters of varying bandwidth. The filters are selected in series, with the overall bandwidth being determined by the narrowest filter used. The front panel SELECTIVITY switch gives the operator the choice of four bandwidths: N, M1, M2, W or AUTO. In FM mode, the SELECTIVITY switch does not work, as the receiver has a fixed 12 kHz bandwidth in FM mode.

### FILTER TYPES

The narrowest filter must be installed in the N position, with M1, M2, and W holding filters of increasing bandwidth. The N position is where a narrow CW filter like the 500 Hz YK88C filter would be installed. There is also a 270 Hz CW filter, the YK88CN, for the CW enthusiast. M2 is where the "stock" 2.4 kHz SSB filter (YK88S) is installed from the factory. There is also a 1.8 kHz SSB filter, the YK88SN, for the SSB work. The W position is where the "stock" AM filter is installed. This is a very poor quality filter, and the first thing you should do is replace this filter with the 6 kHz AM filter YK88A1. There are also a couple of "custom" AM filters with 4 kHz and 6 kHz bandwidths that offer better performance for DX.

In the AUTO position, the bandwidth is automatically selected by the receiver depending upon the mode selected. The following chart shows how the bandwidth is selected according to the mode:

SELECTIVITY	MODE
W	AM
M2	USB/LSB
N	CW
N	FSK

You'll notice that the M1 filter is not selected automatically, and can only be selected by the M1 position of the SELECTIVITY switch.

For a "full-up" shortwave broadcast selection, you can replace the stock AM filter with the YK88A1 filter in W, a custom 4 kHz filter in M2, move the YK88S to M1, and the YK88C in N. If SSB is your specialty, then try the YK88A1 in W, the YK88S in M2, the YK88SN in M1, and the YK88C in N. Try the YK88A1 in W, the YK88S in M2, the YK88C in M1, and the YK88CN in N for CW work.

## INSTALLING FILTERS

Installing the optional filters is easy. The IF board is labeled with each filter position as shown in Figure 3. Simply locate the proper position for the filter you wish to install and feed the leads through the board. The filter will only go in one way. Solder the leads with a low wattage iron as quickly as possible to prevent damage to the board. Each filter position also has a wire with a jumper pin to tell the microprocessor that a filter is installed. These jumpers are labeled (for example M1 FILTER), and when you install a filter you move the jumper pin from NO to YES.

The YK88A1 AM filter is much easier to install. It is mounted with screws and uses connectors to interface to the board. Simply remove the old filter and mate the new filter with the connectors and screw into place.

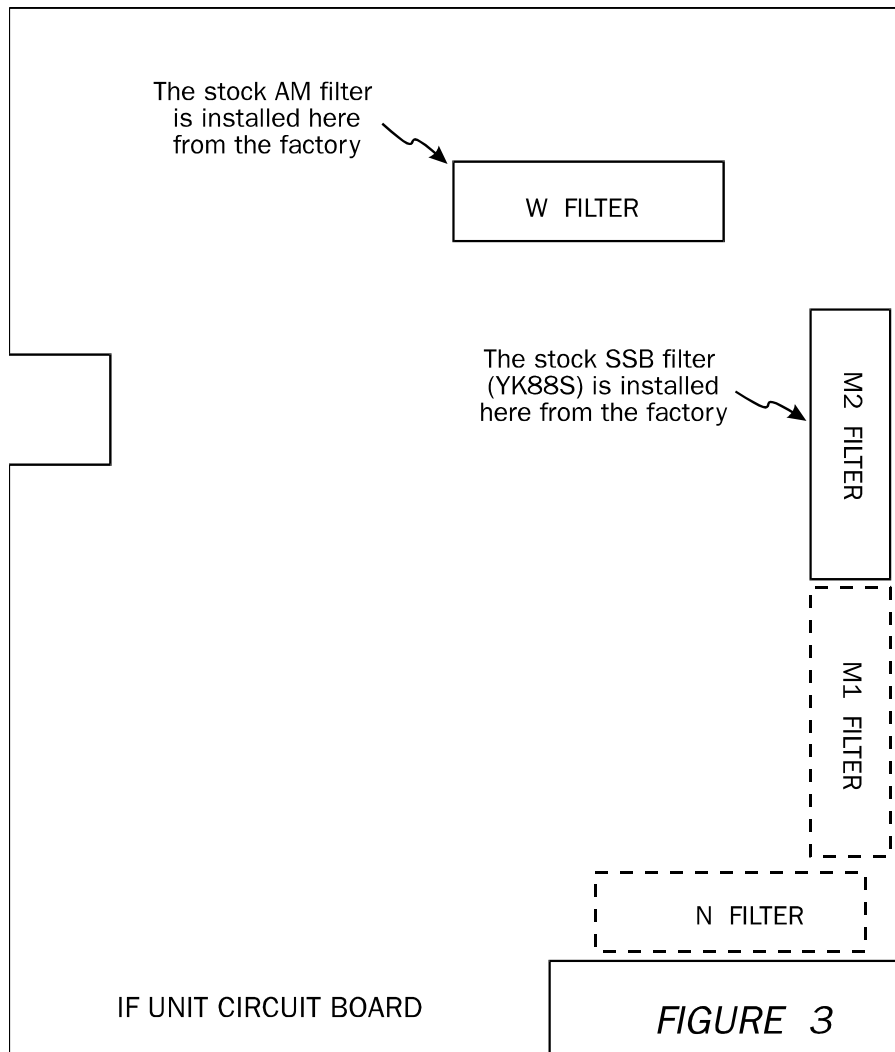

*FIGURE 3*

## EXTERNAL SPEAKER

The R-5000 has an external speaker jack on the rear panel. This allows the user to connect another speaker to the receiver for better sounding audio. Note that when this jack is used the internal speaker is cut off. The internal speaker does not have the best audio quality so an external speaker is a good addition, especially for listening to shortwave broadcasts. The original external speaker designed for the R-5000, the SP-430, is discontinued. The usual replacement is the SP-23 that works but does not match the color or styling of the R-5000.

## DC POWER CABLE KIT

The DC Power Cable Kit DCK-2 allows the R-5000 to run off 13.8 volts DC at 2 amps. It consists of a simple cable with connectors at both ends. One connector plugs into connector 5 located near the corner of the AVR board shown in Figure 4. The other connector mounts to the rear panel. The hole is covered by a metal plate that must be removed first. Included in the kit is a cable to connect the radio to a cigarette lighter in a vehicle. Technically- inclined users can probably make their own cable kit, but this option is tough to beat in price (around \$15).

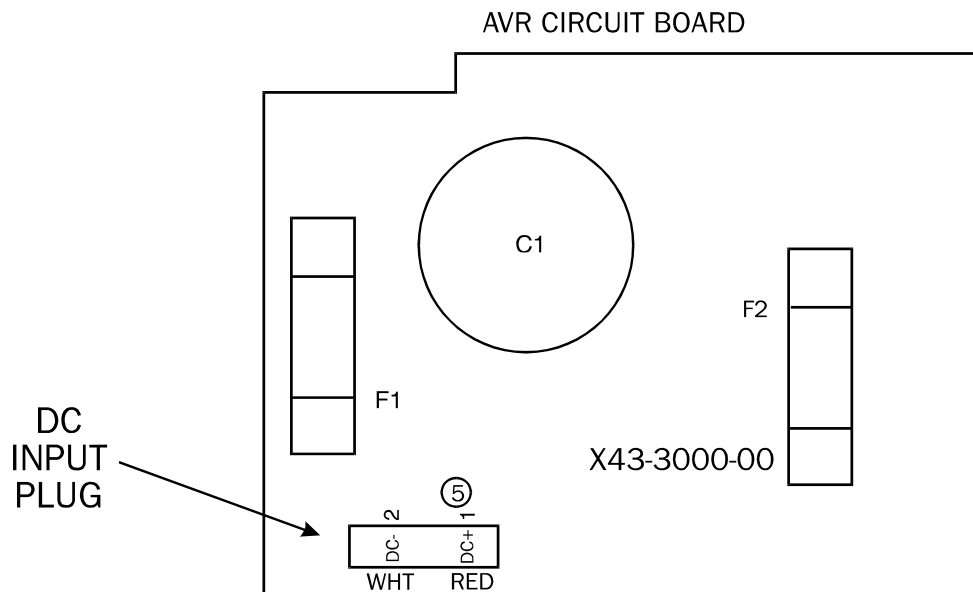

FIGURE 4

## **VOICE SYNTHESIS UNIT**

The VS-1 Voice Synthesis Unit option provides a synthesized voice announcement of the currently displayed frequency. The announcement is made through the speaker (or headphones) whenever the VOICE switch is depressed, and it can be either in English or Japanese. Visually impaired operators can then hear which frequency they are tuned to.

This option is installed in a shielded case on the top left hand side of the chassis next to the AVR board. Two cables with a 3 pin connector and an 8 pin connector are usually stored in this opening. The 3 pin connector goes to the connector labeled J01 on the VS-1 board. The 8 pin connector goes to the connector labeled J02 on the VS-1 board. The board is then vertically secured with two screws. Switch S1 on the VS-1 option selects English or Japanese language, and VR1 adjusts the volume level of the announcement.

## **VHF CONVERTER**

The VC-20 VHF Converter option allows the R-5000 to receive VHF frequencies of 108-174 MHz. These frequencies cover the civilian aviation band of 108-136 MHz, the federal government band of 136-144 MHz, the amateur "2 meter" band of 144-148 MHz, and the public safety band of 148-174 MHz. FM mode is usually used in this area except for AM in the aviation band. The VC-20 has its own antenna jack on the rear panel. This option allows the R-5000 owner to monitor local public safety communications and keep in touch with what is happening in their home town as well as across the globe.

This option mounts on brackets over the top of the IF board in the receiver. Be careful when removing the top cover and disconnect the speaker wires for easy access. Be careful of the delicate wires in this area. The mounting brackets, which are included with the option, should be attached to the sides of the VC-20 first. Next remove the plug from the hole under the VHF ANT label on the rear panel. Slide the VC-20 into the receiver rear-end first to make sure the antenna jack aligns with the hole. Secure with the four screws provided through the R-5000 rear panel. Secure the VC-20 mounting brackets to the two small mounting tabs on the chassis. These tabs are located on both sides of the IF board. Three cables with connectors (2 pins, 7 pins, and 8 pins) are bound together with beaded bands. Remove this band and connect them to the VHF Converter. The 2 pin connector goes to connector location 2, the 7 pin connector to connector location 3, and the 8 pin connector goes to connector location 4 on the front of the VC-20. Plug the coaxial cable connected to the VHF Converter to the connector marked VIF near the front left corner of the IF board. Reconnect the speaker and replace the top cover, taking care not to pinch wires, etc.

To use this option you must press the HF/VHF button on the front panel to switch back and forth between frequency ranges. Note that with this option installed you have two more VFOs for VHF, bringing the total to four for the receiver. The antenna selection switches ANT1 and ANT2 do not function in VHF mode.

## REMOTE CONTROL

The Kenwood R-5000 receiver can be remote-controlled from an external device like a personal computer. To do this, the receiver must first be modified and an external level converter must be used. Each of these can be bought from a dealer or directly from Kenwood. If you are technically capable, you can do these yourself.

Remote control of the R-5000 has a number of applications if you wish to do automatic logging of stations or unattended recording of broadcasts. I find it most useful to mass-program the 100 channels of the R-5000 depending on my listening interest at the time. I can load all the military HF aircraft frequencies in less than 30 seconds! I can then scan those frequencies listening for Air Force One transporting the Big Guy around the world. Then if I want to monitor shortwave broadcasts, I can load all those frequencies quickly and just scroll through the channels looking for the best frequency to catch latest Radio Japan program on learning Japanese. Using the frequency lists published by the monthly monitoring magazines and SW clubs, I can quickly adjust my receiver's channels to the latest frequencies. Some of the remote control programs even have periodic lists available to those who purchased their programs.

### REMOTE CONTROL MODIFICATION

Dealers offer the IC-10 modification kit for the R-5000 for anywhere from \$30 to \$50. The kit simply consists of two ICs: a 4040 CMOS binary counter (IC55) and an 8251A UART (IC54) that are installed into sockets on the control board. If bought from a mail order electronic parts store, these parts will cost less than \$10 (see Appendix A). Figure 5 shows where the two chips are installed on the control board. Please exercise proper CMOS handling procedures when installing these parts! See Appendix C for CMOS handling procedures.

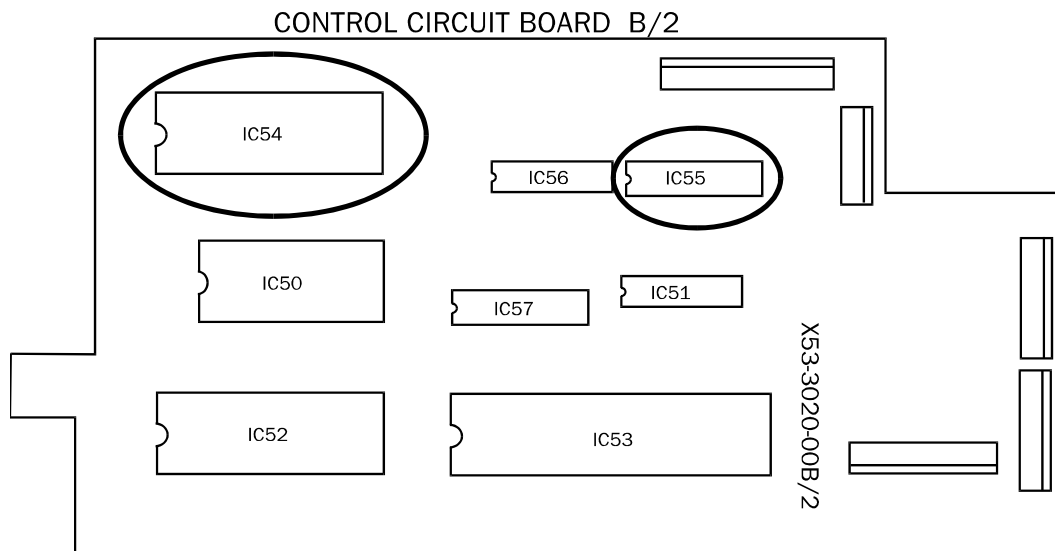

FIGURE 5

## LEVEL CONVERTER

The IF-232C level converter can be purchased from dealers for around \$100. This device converts the TTL levels that the R-5000 uses to RS-232 levels that a terminal or personal computers uses. One end plugs into the ACC connector on the back of the receiver. The other end plugs into the RS-232 connector on the PC (usually labeled COM1:). Figure 6 shows a schematic for a simple version that runs off an external 5-15 VDC supply. The parts can be purchased from most mail order parts stores (see appendix A) or your local Radio Shack. I estimate the cost should be less than \$10-\$15 depending on how you package the project. A wall transformer works well for the power supply. Make sure it is around 5-15 volts DC and not 5-15 volts AC.

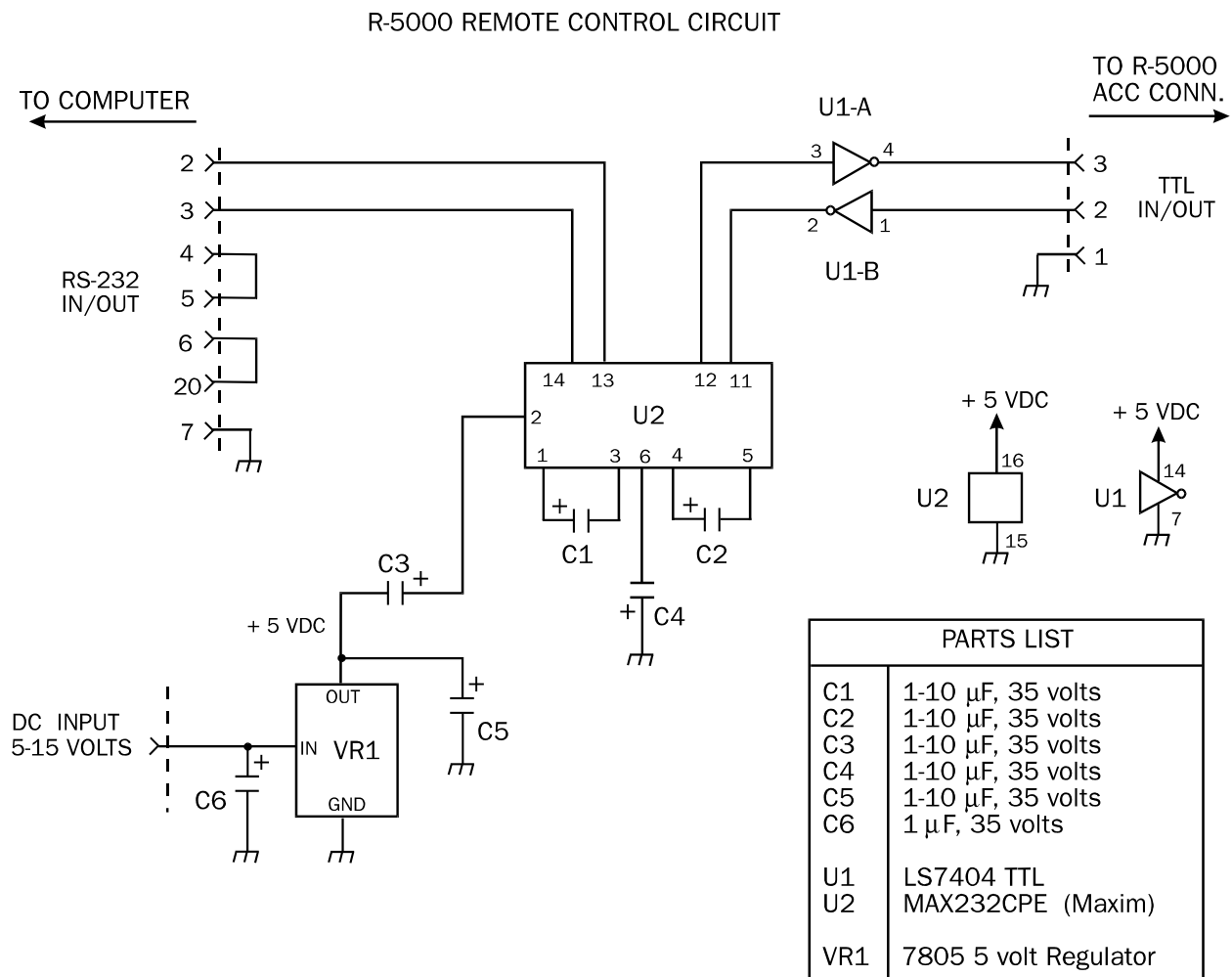

FIGURE 6

## REMOTE CONTROL SOFTWARE

There are a number of software packages specifically written to control the R-5000. These packages allow you to change frequency, mode, channels, etc. Some also allow you to do more advanced features like scanning and programming memory channels. Appendix B lists some of these programs and where to obtain them. Note that some of these programs were designed for the Kenwood TS-440 amateur transceiver, but the receive part of the programs will still work. Note that the R-5000 is a "sister product" to the TS-440, but the receiver design more closely follows that of the TS-940 transceiver.

I find most of these programs are overkill for my personal needs. I like to be able program the channels from my computer, and I prefer to tune the radio from the front panel knobs. I like the ease and speed of programming the channels with the frequencies and modes of interest from my computer. I use a computer modem communications program (Procomm Plus) on my computer and ASCII download text files with the channel information. I can program all 100 channels in about 30 seconds. For example, if I am interested in monitoring military aircraft on HF, I have a ASCII text file called MILAIRHF.TXT that contains frequency and mode information for each channel. I then download this file to the radio and I am ready to go. Below is a sample listing of that file (see REMOTE CONTROL COMMANDS below for description of the command MW):

```
MW 000001117600020 ;  
MW 010001324100020 ;  
MW 020001501500020 ;  
  .  
  .  
  .  
MW 990000899300020 ;
```

This loads channel 00 with 11.176 MHz USB, channel 01 with 13.241 MHz USB, and channel 02 with 15.015 MHz USB, etc. I have found you need to put a single RETURN every 10th line. This seems to allow the radio to keep pace with the incoming commands.

Note that if you download another group of frequencies you will overwrite any previous information programmed in those channels. You can erase all the programming in the receiver by holding down the A=B key on the front panel while you turn the radio on. This will completely erase everything, so be sure you copy down any frequencies of importance first!

## REMOTE INTERFACE INFORMATION

If you would like to use a communications program on your computer to control the R-5000, you will need to set up the interface. The interface to the radio should be at 4800 baud, 8 data bits, 1 start bit, 2 stop bits, with no parity. The receiver does not echo back the commands, so the program must have echo on or be on full duplex. Upper or lower case letters can be used, but each command must be followed by a terminator which is a semicolon (;). If you send a semicolon followed by a RETURN the receiver will send a question mark (?) in response. This is a good check to verify that communications are working.

## REMOTE CONTROL COMMANDS

This is a list of commands that control a Kenwood R-5000 Receiver. The format and spacing are critical. If blank spaces are needed I have pointed them out in the descriptions. Refer to the previous section, REMOTE INTERFACE INFORMATION for an explanation on the protocol requirements and the terminator character.

Each command is listed in the following pages using the basic outline shown below:

### NAME

### COMMAND

LIST OF COMMAND OPTIONS (if any)

COMMAND INFORMATION - Describes what the command does, and how to use the different options.

EXAMPLE - An example of the command using typical options.

**x** - This symbol represents a variable that the user must enter.

## AUTO INFORMATION

**AIx;**

AI0; = OFF

AI1; = ON

**AUTO INFORMATION** - Sends a complete receiver status in the format of the IF command (see below), when front panel controls are changed, to the computer.

**EXAMPLE** - If you enter the command AI1; the auto information function is enabled.

## ANTENNA

**ANx;**

AN1; = ANTENNA 1

AN2; = ANTENNA 2

**ANTENNA** - Selects either antenna port 1 or antenna port 2.

**EXAMPLE** - If you enter the command AN2; antenna port 2 is selected.

## DOWN

**DN;**

**DOWN** - If the receiver is in VFO mode, moves the current VFO down in frequency according to step switch. Refer to the R-5000 manual for the step sizes for each mode. If in memory channel mode, moves the receiver down one channel.

**EXAMPLE** - If you enter the command DN; the frequency is decreased 1 kHz if the receiver is in AM mode, either VFO A or VFO B is selected, and the step switch is off.

## FREQUENCY READ

**Fx;**

FA; = VFO A

FB; = VFO B

**FREQUENCY READ** - Receiver will send back frequency of that VFO in the format below:

Fx00000000000;

**EXAMPLE** - If you enter the command FA; and the receiver sends back FA00006955000;, this means VFO A is set at 6.955 MHz.

## FREQUENCY INPUT

**Fx00000000000;**

FA00000000000; = VFO A

FB00000000000; = VFO B

**FREQUENCY INPUT** - Change frequency of the desired VFO in the format below:

Fx00000000000;

**EXAMPLE** - If you enter the command FA00006955000; the receiver changes VFO A to a frequency of 6.955 MHz.

## FUNCTION SELECT

**FNx;**

FN0; = VFO A

FN1; = VFO B

FN2; = MEMORY CHANNEL MODE

**FUNCTION SELECT** - Select which VFO the receiver is using or puts the receiver in memory channel mode.

**EXAMPLE** - If you enter the command FN1; VFO B is selected.

**IDENTIFICATION**

**ID;**

**IDENTIFICATION** - Receiver will send back the ID number for the particular Kenwood model number. The R-5000 will return ID005;.

**EXAMPLE** - If you enter the command ID; the receiver sends back ID005;.

**INFORMATION**

**IF;**

**INFORMATION** - Receiver will send back complete radio status in the format below:

IF00000000000000000000 000000 ;

The last field follows the first by 8 spaces. The semicolon follows the last field by 5 spaces. Each position is outlined below.

**Receiver Frequency** - The first eleven positions of the first field indicate the receiver's frequency:

IF00000000000000000000 000000 ;

**Frequency Step** - The last five positions of the first field indicate the frequency step:

IF000000000000000000 000000 ;

FIELD	FREQ.	MODE	STEP
01000	1 kHz	AM	OFF
00100	100 Hz	AM/USB/LSB/CW/FSK	ON
00010	10 Hz	USB/LSB/CW/FSK	OFF
05000	5 kHz	FM	OFF
02500	2.5 kHz	FM	ON

**Memory Channel** - The first two positions of the last field indicate the memory channel the receiver is on:

IF000000000000000000000000 000000 ;

The third position of the last field is not used and is always zero for the R-5000.

IF000000000000000000000000 000000 ;

**Mode** - The fourth position of the last field indicates the mode of the receiver:

IF000000000000000000000000 000000 ;

The mode is indicated by:

- 1 = LSB
- 2 = USB
- 3 = CW
- 4 = FM
- 5 = AM
- 6 = FSK

**Function** - The fifth position of the last field indicates the current function of the receiver:

IF000000000000000000000000 000000 ;

The function is indicated by:

- 0 = VFO A
- 1 = VFO B
- 2 = MEMORY CHANNEL MODE

**Scan** - The last position of the last field indicate whether the receiver is in scan or not:

IF000000000000000000000000 000000 ;

The scan is indicated by:

- 0 = OFF
- 1 = ON (scanning)

**EXAMPLE** - If you enter the command IF; and the receiver sends back complete status of:

IF0000741500001000 220520 ;

Reading left to right, the first field states the receiver is set at 7.415 MHz and a step frequency of 1 kHz. The last field states the receiver is on channel 22, in AM mode, memory channel mode, and the radio is not scanning.

Note: Even if the receiver is not in memory channel mode (i.e. VFO A is selected), the IF status will still indicate a memory channel as does the front panel of the receiver.

## LOCK

**LKx;**

LK0; = UNLOCK

LK1; = LOCK

**LOCK** - Enables or disables the frequency lock function of the receiver. This also works on frequency changes from the remote.

**EXAMPLE** - If you enter the command LK1; any frequency changes are prevented.

## MEMORY CHANNEL

**MC x x;**

**MEMORY CHANNEL** - Selects a memory channel independent of the current receiver function. A single space between the MC and the actual channel number is necessary.

**EXAMPLE** - If you enter the command MC 19; channel 19 is selected on the receiver.

## MODE CHANGE

**MDx ;**

MD1; = LSB

MD2; = USB

MD3; = CW

MD4; = FM

MD5; = AM

MD6; = FSK

**MODE CHANGE** - Changes the mode of the receiver.

**EXAMPLE** - If you enter the command MD3; the receiver is changed to CW mode.

## MEMORY READ

**MR x x;**

**MEMORY READ** - Reads contents of memory channel **x x**. Two spaces between the MR and the actual channel number is necessary. The receiver will send back the contents of that memory channel in the format below:

MR000000000000000000 ;

The semicolon follows the last field by 4 spaces. Each position is outlined below.

The first two positions are not used.

MR000000000000000000 ;

**Channel Number** - The third and four positions indicate the memory channel number:

MR000000000000000000 ;

**Frequency** - The fifth through the fifteenth position indicates the channel's frequency:

MR000000000000000000 ;

**Mode** - The sixteenth position indicates the mode the memory channel is programmed with:

MR0000000000000000 ;

The mode is indicated by:

- 1 = LSB
- 2 = USB
- 3 = CW
- 4 = FM
- 5 = AM
- 6 = FSK

**Channel Lock** - The last position indicates whether the channel is locked out for memory scan:

MR00000000000000000 ;

The lockout is indicated by:

0 = NOT LOCKED OUT

1 = LOCKED OUT

**EXAMPLE** - If you enter the command MR22; and the receiver sends back:

MR00220000741500060 ;

Reading left to right, this means that memory channel 22 is programmed with a frequency of 7.415 MHz, FSK mode, and the channel is not locked out for memory scan.

## MEMORY WRITE

**MW 0000000000000000** ;

**MEMORY WRITE** - Writes information into a specific memory channel in the following format. The two spaces between the MW and the actual information are necessary. The semicolon follows the last field by 4 spaces. Each position is outlined below.

**Memory Channel** - The first two positions are for the channel number:

MW 000000000000000000 ;

**Frequency** - The third through the thirteenth position are for the memory channel's frequency:

MW 0000000000000000 ;

**Mode** - The fourteenth position is for the mode the memory channel is to be programmed with:

MW 00000000000000 ;

The mode is indicated by:

1 = LSB

2 = USB  
3 = CW  
4 = FM  
5 = AM  
6 = FSK

**Channel Lock** - The last position is used to lock out the channel for memory scan:

MW 0000000000000000\_ ;

The lockout is indicated by:

0 = NOT LOCKED OUT  
1 = LOCKED OUT

**EXAMPLE** - If you enter the command:

MW 220000741500050 ;

Reading left to right, this means that memory channel 22 will be programmed with a frequency of 7.415 MHz, AM mode, and the channel will not be locked for memory scan.

NOTE: Writing all zeros to a channel will clear that channel. For example to clear channel 32:

MW 3200000000000000 ;

## POWER

**PSx;**

PS0; = RECEIVER OFF

PS1; = RECEIVER ON

**POWER** - The receiver can be powered on or off from the remote.

**EXAMPLE** - If you enter the command PS0; and the receiver is on, the receiver will turn off.

## SCAN

**SCx;**

SC0; = SCAN OFF  
SC1; = SCAN ON

**SCAN** - Enables or disables the scan function of the receiver. Refer to the instruction manual for details on how the scanning function operates in Memory Scan and Program Scan.

**EXAMPLE** - If you enter the command SC1; the receiver will go into the scan mode.

**NOTE:**

The scan group in Memory Scan can only be entered from the receiver. The R-5000 remembers the group from the last memory scan. The receiver will then scan that group if you initiate a memory scan from the remote. The default is all groups are selected.

In Program Scan you must first select a channel from the group that has the frequency limits in channels x8 and x9. For example, you want to Program Scan between the frequencies in channels 18 and 19. First you must select a channel between 10 and 19 using the MC **x x**; command (see above) like MC 15;. Then you start the scan (while in VFO mode) using the command SC1;.

**STEP**

**STx;**

ST0; = STEP OFF  
ST1; = STEP ON

**STEP** - Enables or disables the frequency step function of the receiver. See the table below for the different frequency steps for each mode and step condition.

STEP	MODE	STEP FREQ.
OFF	AM	1 kHz
ON	AM	100 Hz
OFF	USB/LSB/CW/FSK	10 Hz
ON	USB/LSB/CW/FSK	100 Hz
OFF	FM	5 kHz
ON	FM	2.5 kHz

**EXAMPLE** - If you enter the command ST1; and the receiver is in AM mode, the step frequency will change from 1 kHz to 100 Hz.

## UP

**UP;**

**UP** - If the receiver is in VFO mode, moves the current VFO up in frequency according to step switch. Refer to the R-5000 manual for the step sizes for each mode. If in memory channel mode, moves the receiver down one channel.

**EXAMPLE** - If you enter the command UP; the frequency is increased 1 kHz if the receiver is in AM mode, either VFO A or VFO B is selected, and the step switch is off.

## VOICE RECALL

**VR;**

VR0; = VOICE RECALL OFF

VR1; = VOICE RECALL ON

**VOICE RECALL** - Enables or disables the voice synthesizer generator function of the receiver. This command will not work unless the Voice Synthesis option is installed.

**EXAMPLE** - If you enter the command VR1; the receiver will announce the operating frequency by voice synthesis.

## **SERVICE BULLETINS**

The only service bulletin I have found for the R-5000 is number SB-919 dated 7-21-87. It involves the capability to change the frequency from the remote interface. This only seems to be a issue with receivers of serial number 8049999 or less. The problem can be corrected by making sure the Integrated circuit in IC52 is an MBM27C128-25JA2.

## APPENDIX A

This appendix lists the addresses, phone numbers, etc. of various Kenwood offices, dealers and electronic part stores. Also listed are some addresses from the World Wide Web that may be of interest.

Kenwood USA Corporation  
2201 E. Dominguez Street  
P.O. Box 22745  
Long Beach, CA 90810

SALES  
1-800-435-6966

CUSTOMER SERVICE  
(310) 639-7140  
(310) 631-3913 (fax)

PARTS  
1-800-262-1312  
(310) 515-0207  
(310) 538-4919 (fax)

TECHNICAL ASSISTANCE  
(310) 639-9000

BBS  
761-8284

WORLD WIDE WEB  
<http://www.kenwood.net/>

SERVICE CENTER - EAST  
Kenwood Service Center East  
Suite 130  
910 South Lynn Haven Parkway  
Virginia Beach, VA 23452  
(804) 340-1702  
(804) 340-6809 (fax)

PARTS - EAST COAST  
East Coast Transistor Parts Inc.  
P.O. Box 238  
2 Marlborough Road  
West Hempstead, New York 11552  
(516) 483-5742  
(516) 483-5904 fax  
1-800-637-0338 (outside New York State)

## **DEALERS**

Although the Kenwood R-5000 is no longer offered, these dealers will be able to help with repairs, accessories, etc. Some will also have generic amateur radio and shortwave information as well.

Amateur Electronic Supply  
5710 W. Good Hope Road  
Milwaukee, WI 53223  
1-800-558-0411 (orders)  
(414) 358-0333 (technical)  
358-3337 (fax)  
<http://www.aesham.com/>

Grove Enterprises  
P.O. Box 98  
Brasstown, NC 28902  
1-800-438-8155 (orders)  
(704) 837-7081 (technical)  
(704) 837-9200 (office)  
(704) 837-2216 (fax)  
<http://www.grove-ent.net/>

Universal Radio Inc.  
68330 Americana Parkway  
Reynoldsburg, OH 43068  
1-800-431-3939 (orders)  
(614) 866-4267 (technical)  
866-2339 (fax)  
<http://www.universal-radio.com/>

## **ELECTRONIC PART STORES**

Digi-Key Corporation  
701 Brooks Ave. South  
P.O. Box 677  
Thief River Falls, MN 56701  
1-800-344-4539  
681-3380 (fax)  
<http://www.digikey.com/>

Jameco Electronics  
1355 Shoreway Road  
Belmont, CA 94002  
1-800-831-4242  
1-800-237-6948 (fax)  
<http://www.jameco.com/>

## **WORLD WIDE WEB PAGES**

Here are some radio-related pages on the World Wide Web. They may have shareware versions of the remote control programs, generic information on the Kenwood R-5000, or shortwave /amateur radio in general. Pages come and go on the Web, so I can't guarantee these sites will always work. There are thousands of pages with new ones being added all the time. Try using one of the search engines (Yahoo, Excite, etc.) and search for words like R-5000, Kenwood, shortwave, and the like.

- QSL Net  
<http://www.qsl.net/>
- TRS Consultants  
<http://www.trsc.com/>
- Shortwave Radio Catalog  
<http://itre.ncsu.edu/radio/>
- Association of North American Radio Clubs  
[http://www.anarc.org /](http://www.anarc.org/)
- Ontario DX Association  
<http://www.durhamradio.ca/odxa/>
- Radio Netherlands  
<http://www.rnw.nl/realradio/r5000.html>

## **APPENDIX B**

This appendix lists various remote control programs that I have tried for the Kenwood R-5000 radio. Some have been around for years, and may or may not be updated since my initial review of them. Only programs for IBM compatible computers are listed. Included are remote control programs specifically for controlling the Kenwood R-5000. Some of these were also written for the Kenwood TS-440 transceiver, but the receiver commands are identical. Some also control other radios other than the R-5000.

Some of these programs are "shareware" available on CD ROMS, or World Wide Web pages that cater to the shortwave hobby or amateur radio (see Appendix A for a list of Web pages that may have these programs). Shareware is a form of software, usually written by individuals, that is lower in cost than commercially available programs. Shareware is distributed on a trial basis. If you continue to use the program, a small donation (usually \$20-\$40) should be paid to the author. Most of the people who write Shareware do it for fun and not for profit. Supporting them will only foster the idea of affordable software.

Also listed is a common modem communications program called Procomm Plus. Those who wish to enter the commands manually can use this program. Any similar program written for computers to talk to each other through modems can be used. You can use these programs to send single commands or to download channel memory information. The more advanced computer users could write small script files to do multiple commands.

### **REMOTE CONTROL PROGRAMS**

#### **1) SMART KENWOOD CONTROL**

This program allows you to run your Kenwood radio from the Microsoft Windows environment. Smart Kenwood Control is a sophisticated and versatile remote control program, and is very user friendly. It allows tuning and memory channel management as well as all the other remote control functions. The user interface is in the typical Windows style of scroll bars, buttons, icons, etc. The tuning window also shows the status of both VFOs and memory, as well as which antenna is selected. The program uses an awesome database of frequencies for broadcasters and utility stations. This database contains not only the frequencies for most shortwave stations, but also their broadcast schedules. You can simply enter the current time and a window shows you which stations are broadcasting and what frequency to tune to. Tuning is then as simple as clicking you mouse on the frequency. Updates to the database can be obtained from the company or the user can enter their own. Smart Kenwood Control also works with the TS-440 Transceiver. Overall this program does a great job of controlling the radio. An evaluation copy of Smart Kenwood Control program by Fineware can be download from the World Wide Web at <http://www.erols.com/fineware/skc.html>.

## 2) SCANCAT

This program is designed to control several different receivers from different manufacturers including the R-5000. Scancat is also a very advanced and multipurpose remote control program. You can enter frequencies, select a VFO or memory, change mode, and load/read memory channels. Several sample channel files are included, and you can create your own. You can read the channels in the radio and store them into a file. The strength of this program is in its scanning capability. You can scan between any two frequencies at any rate and increment. This program also comes in a couple of versions, a basic version and a more advanced one. The company offers a demonstration disk or a downloadable evaluation copy with limited capabilities. Scancat is available on the Web at <http://www.scancat.com/>, or from:

J & J Enterprises  
4001 Parkway Drive  
Bossier City, LA 71112

## 3) HAMWINDOWS PLUS

This program controls the R-5000 (and others) from Microsoft Windows. I have not tried this program but according the review in Monitoring Times magazine (Sept-Oct '93) it is the ultimate in a remote control program. But all these capabilities come at a high price (list is around \$190). HamWindows Plus is available from:

California Software Inc.  
2121 E. Pacific Coast Hwy.  
#220 Corona del Mar, CA 92625

## 4) 440 SPOILER

A simple menu-driven program to control the TS-440 transceiver, but will work on R-5000. 440 Spoiler is an older DOS based program that has been around for years. It allows you to change one function at a time by selecting a letter from a menu. This is one step above using a modem communications program and typing the commands in yourself. 440 Spoiler is shareware and is available from:

QSO2000 Project  
5518 12th Street  
Lubbock, TX 79415

#### 4) PROCOMM PLUS

Procomm Plus is a commercial program designed for computer to computer communications via phone line modems. It can be used to send single commands to the Kenwood R-5000, as a "poor-mans" remote control. Unfortunately the program is not as cheap as the programs listed above. Procomm Plus can be found at most computer stores, the Web at <http://www.symantec.com/procomm/procomm.html>, or directly from Symantec at:

Symantec Corporation  
175 west Broadway  
Eugene, OR 97401

## APPENDIX C

Complementary Offset Symmetry Metal-Oxide Semiconductor (CMOS) devices have diode protection against detrimental electrical conditions such as static electricity. Although these devices contain circuitry to protect their inputs against damage from high voltages, care should be taken in handling them.

Severe electrical conditions can occur during handling. Static electricity generated by someone walking across a rug can be as high as 4 to 15 kV. This depends upon the humidity, friction, and other factors. These voltages can be disastrous when discharged into a CMOS part. CMOS devices have built-in protection which can protect itself from overvoltages. However, they can not protect the part from the high voltages described above.

Below are some suggested CMOS handling procedures. If you are not sure what you are doing, enlist the help of an experienced technician.

All CMOS parts should be stored and transported in the package they were delivered in. This package prevents static electrical charges from building up. Never use plastic bags or bins.

1. Avoid contact with the leads of the part. Always handle the part by the ends or sides opposite the leads.
2. Avoid contact between printed wiring boards or CMOS parts and synthetic clothing while handling static sensitive parts or boards containing static devices.
3. Do not insert or remove CMOS parts with the power still applied to the unit.
4. Use only soldering irons and tools that are properly grounded. Ungrounded soldering iron tips will destroy CMOS parts. Never use soldering guns.

# Other ManualsLib Projects



[www.manualslib.com](http://www.manualslib.com)



[www.manualslib.de](http://www.manualslib.de)



[www.manualslib.es](http://www.manualslib.es)



[www.manualslib.fr](http://www.manualslib.fr)



[www.manualslib.nl](http://www.manualslib.nl)



[www.manualslib.mx](http://www.manualslib.mx)



[www.manualslib.tech](http://www.manualslib.tech) 30+ Languages