

# KENWOOD R-5000 SERVICE MANUAL



## Table of Contents

[Contents](#)

[Circuit description](#)

[Overview](#)

[Frequency configuration](#)

[Signal frequency configurations](#)

[PLL Frequency configurations](#)

[Circuit configuration](#)

[Series connection of IF filters](#)

[IF filter connection in the conventional models](#)

[IF filter connection](#)

Noise blanking

Selectivity responds each auto mode

Selectivity switch peripheral circuit

Notch circuit

NB rate control pulse performing circuit

AGC and S Meter Circuits

Muting circuit

Analog switch

PLL circuit

Reference oscillator circuit

PLL4

PLL1

PLL2

PLL3

PLL5

Unlocked signals

MKR signal

Digital control

Control circuit block diagram

Details of the units

Encoder circuit

System clock and system reset circuits

Address control

Address control division

System clock oscillation circuit

Real-time clock

Display driver interface

Digital display circuit

A/D converter analog input

A/D converter peripheral circuit

A/D converter data timing chart

PLL data

Band information

Key Scan

Extended functions

Static input

Keyscan matrix

External control baud rate oscillation circuit

Output ports

Serial interface baud rate oscillation circuit

Semiconductor data

Keyboard Ass'y

Terminal connection diagram

Block diagram

Description of components

IF Unit

Parts List

Capacitors

Temperature coefficient

Tolerance

Semiconductor

Disassembly

Adjustment

Required test equipment

DC Voltmeter

DC Ammeter

PLL Adjustment

Top view

[Bottom view](#)

[Level diagram](#)

[RF Unit](#)

[Circuit diagram](#)

[PC Board Views](#)

[Control unit](#)

[Switch unit](#)

[Terminal function](#)

[VS-1](#)

[VC-20](#)

[Installation of options](#)

[Voice synthesis unit VS-1](#)

[Crystal filter](#)

[Voltage measurement conditions](#)

[FM mode receiving](#)

[Interface Chip IC-10](#)

[DC Power Cable Kit](#)

[VHF Converter](#)

[Specifications](#)

[Other ManualsLib Projects](#)

COMMUNICATIONS RECEIVER

# R-5000

## SERVICE MANUAL

# KENWOOD

©1986-10/87-2 PRINTED IN JAPAN  
B51-3073-00 (O) 150



## CONTENTS

CIRCUIT DESCRIPTION .....	2	MB-430 (MOBILE MOUNT) .....	88
SEMICONDUCTOR DATA .....	24	SP-430 (SPEAKER) .....	88
DESCRIPTION OF COMPONENTS .....	33	VS-1 (VOICE SYNTHESIZER) .....	88
PARTS LIST .....	41	VC-20 (VHF CONVERTER)	
DISASSEMBLY .....	64	SPECIFICATIONS .....	89
PACKING .....	68	CIRCUIT DESCRIPTION .....	89
ADJUSTMENT .....	69	BLOCK DIAGRAM .....	90
LEVEL DIAGRAM .....	76	TERMINAL FUNCTION .....	91
BLOCK DIAGRAM .....	76	PARTS LIST .....	91
PC BOARD VIEWS/CIRCUIT DIAGRAMS		ADJUSTMENT .....	99
RF UNIT (X44-3010-00) .....	76	PC BOARD VIEWS .....	100
IF UNIT (X48-3000-00) .....	78	CIRCUIT DIAGRAM .....	101
PLL UNIT (X50-3030-00) .....	80	INSTALLATION OF OPTIONS	
CONTROL UNIT (X53-3020-XX) .....	82	CRYSTAL FILTERS .....	102
SWITCH UNIT (X41-3000-00) .....	84	VS-1 .....	102
AVR UNIT (X43-3000-00) .....	84	IC-10 .....	103
DISPLAY UNIT (X54-3010-00) .....	84	DCK-2 .....	104
SCHMATIC DIAGRAM .....	85	VC-20 .....	105
TERMINAL FUNCTION .....	86	SPECIFICATIONS .....	BACK COVER
OPTION FILTER .....	87		

### Caution :

Optional accessory installation — The user should not attempt to install the optional accessory beyond that described in the operating instructions. All installations should be referred to qualified service personnel.

## CIRCUIT DESCRIPTION

### OVERVIEW

The R-5000 is a double-conversion general-coverage receiver with a first IF (intermediate frequency) of 58.1125 MHz and second IF of 8.83MHz. (In the FM mode triple conversion is used with a third IF of 455kHz.) It can receive AM, LSB, USB, CW, FM, and RTTY signals from 30kHz to 30MHz, with performance specifications guaranteed from 100kHz up. The VC-20 VHF converter option extends the receiving range to 108MHz to 174MHz.

Interference is removed by an IF filter switching circuit and 0-to-30dB RF attenuator. The receiver also has an IF shift feature, AF notch filter (not used in the CW mode), and AF peak filter (CW mode only).

The receiver's phase-locked loops operate under micro-processor control. High frequency stability and accuracy are achieved by a single-crystal system that provides digital frequency control in 10Hz steps. This includes the frequencies of the VHF converter.

Other major features of the R-5000 receiver are

1. Reduction of many types of impulse noise controlled by two noise blanker switches and a noise-blanker level control.
2. Two digital VFOs (Variable-Frequency Oscillators).
3. Direct entry of frequencies thru the use of numeric keypad.
4. A memory that stores band, mode, and antenna (1 or 2) information for 100 channels.
5. Memory scanning and ten types of programmed scanning.
6. A built-in timer and dual-time clock.
7. Display dimmer.
8. The VS-1 voice synthesizer option internal installation.
9. Possible interfacing to a personal computer.
10. A rechargeable lithium backup battery for the micro-processor.
11. A built-in AC power supply (the receiver can also operate on an external DC power supply).

### Frequency Configuration

The R-5000 operates as a triple-conversion receiver in the FM mode and as a double-conversion receiver in other modes. **Fig. 1** shows the principal frequencies used in its signal circuits. Consider an HF-band signal received in the SSB mode. Let  $f_{IN}$  be the frequency input from the antenna,  $f_{VCO}$  the local oscillator frequency input by the first mixer (MIX1),  $f_{HET}$  the local oscillator frequency input by the second mixer (MIX2), and  $f_{BFO}$  the beat-frequency oscillator input from the detector. When  $f_{IN}$  is at zero-beat – that is, when the SSB signal is zeroed in with  $f_{IN}$  as the carrier point – the following relationship holds true :

- (1) First IF at the MCF input  
 $f_{VCO} - f_{IN} = 1st\ IF\ (58.1125MHz) \dots\dots\dots ①$
- (2) Second IF at the XF input  
 $1st\ IF - f_{HET} = 2nd\ IF\ (8.83MHz) \dots\dots\dots ②$

- (3) At the detector input  
 $2nd\ IF - f_{BFO} = 0\ (AF\ signal) \dots\dots\dots ③$
  - (4) Substituting the left side of Eq. (2) into (3) and the left side of Eq. (1) into (2) gives  
 $f_{VCO} - f_{IN} - f_{HET} - f_{BFO} = 0 \dots\dots\dots ④$
  - (5) Which can be rewritten as  
 $f_{IN} = f_{VCO} - f_{HET} - f_{BFO} \dots\dots\dots ⑤$
- Equation ⑤ describes the frequency relationship of the signal circuits.

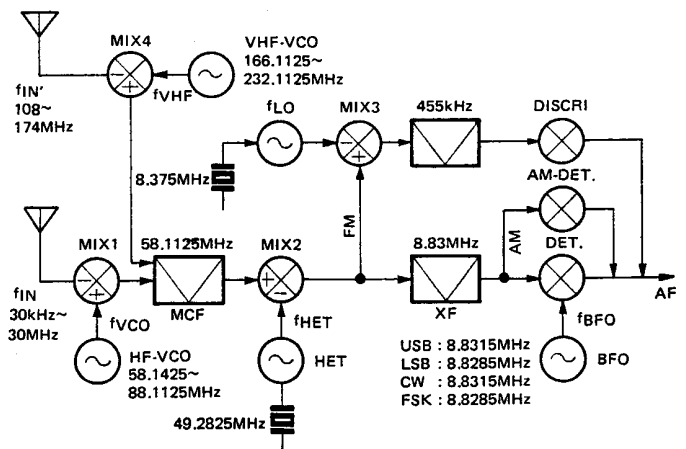

**Fig. 1 Signal frequency configurations**

Consider next the  $f_{VCO}$  frequencies from the PLL circuits.

- (1) In PLL1  
 At \*1,  
 $f_{VCO1} = \frac{1}{4500} \cdot \frac{1}{2} f_{STD} \cdot N1 \dots\dots\dots ⑥$
- At \*2,  
 $f_{VCO1}' = \frac{1}{200} \cdot f_{VCO1} \dots\dots\dots ⑦$
- At \*3,  
 $f_{VCO1}'' = f_{VCO1}' + f_{BFO} + f_{HET} \dots\dots\dots ⑧$
- (2) In PLL2  
 $f_{VCO2} - f_{VCO1}'' = PLL2\ IF \dots\dots\dots ⑨$   
 $\therefore f_{VCO2} = f_{VCO1}'' + PLL2\ IF \dots\dots\dots ⑨$   
 where the intermediate frequency PLL2 IF is:  
 $PLL2\ IF = \frac{1}{180} \cdot \frac{1}{2} f_{STD} \cdot N2 \dots\dots\dots ⑩$
- (3) In PLL3  
 $f_{VCO2} - f_{VCO} = PLL3\ IF \dots\dots\dots ⑪$   
 $\therefore f_{VCO} = f_{VCO2} - PLL3\ IF \dots\dots\dots ⑪$   
 where the intermediate frequency PLL3 IF is:  
 $PLL3\ IF = \frac{1}{18} \cdot \frac{1}{2} f_{STD} \cdot N3 \dots\dots\dots ⑫$
- (4) These equations can be combined by substituting ⑥ and ⑦ into ⑧ to obtain  
 $f_{VCO1}'' = \frac{1}{200} \cdot \frac{1}{4500} \cdot \frac{1}{2} f_{STD} \cdot N1 + f_{BFO} + f_{HET}$

# CIRCUIT DESCRIPTION

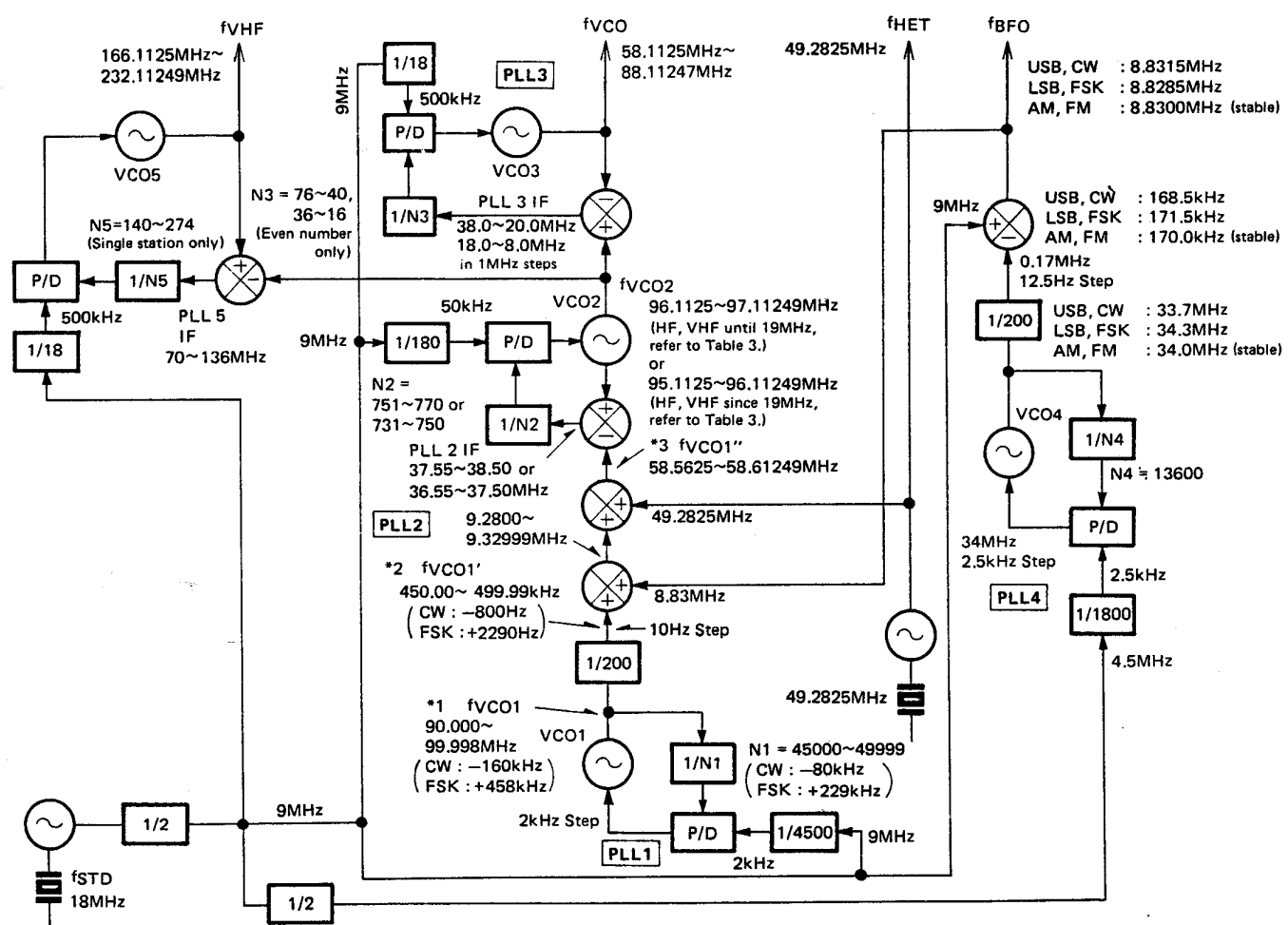

Fig. 2 PLL frequency configurations

(5) and substituting ⑩ and ⑬ into ⑨ to obtain

$$f_{VCO2} = \frac{N1}{1800000} f_{STD} + f_{BFO} + f_{HET} + \frac{N2}{360} f_{STD} \dots \textcircled{14}$$

(6) Substitution of ⑫ and ⑭ into ⑪ then gives

$$f_{VCO} = \frac{N1}{1800000} f_{STD} + f_{BFO} + f_{HET} + \frac{N2}{360} f_{STD} - \frac{N3}{36} f_{STD} \dots \textcircled{15}$$

This derivation of fVCO from the PLL system implies the following relation between the PLL and signal circuits.

(1) Substituting ⑮ into ⑤, we get

$$\begin{aligned} f_{in} &= f_{VCO} - f_{HET} - f_{BFO} \\ &= \frac{N1}{1800000} f_{STD} + f_{BFO} + f_{HET} + \frac{N2}{360} f_{STD} - \frac{N3}{36} f_{STD} \\ &\quad - f_{HET} - f_{BFO} \\ &= \frac{N1}{1800000} f_{STD} + \frac{N2}{360} f_{STD} - \frac{N3}{36} f_{STD} \\ &= \left( \frac{N1}{1800000} + \frac{N2}{360} - \frac{N3}{36} \right) f_{STD} \dots \textcircled{16} \end{aligned}$$

(1) If the same relations are considered in the VHF band, at the fourth mixer (MIX4) in the signal system

$$f_{VHF} - f_{in'} = 1 \text{ st IF}$$

The rest follows the same development as in the HF band. From Eqs. (2) and (3) above.

$$f_{VHF} - f_{in'} - f_{HET} - f_{BFO} = 0$$

$$\therefore f_{in'} = f_{VHF} - f_{HET} - f_{BFO} \dots \textcircled{17}$$

(2) In the PLL system, the decades from PLL2 on down follow the same path as in the HF band, so the same calculations can be performed.

(3) At PLL5

$$f_{VHF} - f_{VCO2} = \text{PLL 5 IF}$$

$$\therefore f_{VHF} = f_{VCO2} + \text{PLL 5 IF} \dots \textcircled{18}$$

where PLL5 IF is given by

$$\text{PLL 5 IF} = \frac{1}{18} \cdot \frac{1}{2} f_{STD} \cdot N5 \dots \textcircled{19}$$

## CIRCUIT DESCRIPTION

(4) Substitution of ⑭ and ⑰ into ⑱ gives

$$f_{VHF} = \frac{N1}{1800000} f_{STD} + f_{BFO} + f_{HET} + \frac{N2}{360} f_{STD} + \frac{N5}{36} f_{STD} \dots\dots\dots ⑳$$

(5) Substitution of ⑳ into ⑰ gives

$$f_{IN} = \underbrace{\frac{N1}{1800000} f_{STD} + f_{BFO} + f_{HET} + \frac{N2}{360} f_{STD} + \frac{N5}{36} f_{STD}}_{f_{VHF}} - f_{HET} - f_{BFO}$$

$$= \frac{N1}{1800000} f_{STD} + \frac{N2}{360} f_{STD} + \frac{N5}{36} f_{STD}$$

$$= \left( \frac{N1}{1800000} + \frac{N2}{360} + \frac{N5}{36} \right) f_{STD} \dots\dots\dots ㉑$$

From Eqs. ⑱ and ㉑ it can be seen that in both the HF and VHF bands the  $f_{BFO}$  and  $f_{HET}$  terms drop out, leading to the conclusion that **the receiving frequency is determined by the standard reference frequency and the division ratios N1, N2, N3 and N5.**

Further analysis indicates the following:

- i) Since the values of N1, N2, N3, and N5 are determined by the microprocessor according to the operating frequency, they are not subject to error or drift.
- ii) Since the expression is linear in  $f_{STD}$  the accuracy of the operating frequency equals the accuracy of the standard reference frequency.
- iii) Since there are no terms involving  $f_{BFO}$  and  $f_{HET}$ , the operating frequency is unaffected by variations in  $f_{BFO}$  and  $f_{HET}$ .

The crystal oscillator that produces the reference frequency  $f_{STD}$  of the R-5000 is accurate to within 10ppm (at  $-10^{\circ}\text{C}$  to  $50^{\circ}\text{C}$ ). From i) and ii), it follows that the overall accuracy is that same at any point in the range of 30kHz to 30MHz and 108MHz to 174MHz. Additionally iii) implies that the variable-band functions of IF-shift etc. can be realized easily by controlling  $f_{BFO}$  (the division ratio of PLL4).

The discussion above has dealt with the SSB mode, but a similar argument applies to all modes except the FM mode to show that the receiving frequency is determined by the standard reference frequency  $f_{STD}$  and N1, N2, N3, and N5 alone.

To generate 800Hz receiver beats in the CW mode, the frequency of PLL1 is shifted 800Hz down.

To match the receiver frequency to the space frequency in the FSK mode, the frequency of PLL1 is shifted 2290 Hz lower.

Mode	Displayed frequency
USB, LSB	Carrier point frequency
CW	BFO frequency + 800Hz
AM, FM	IF filter nominal center frequency
FSK	BFO frequency + 2290Hz

### Circuit Configuration

From the antenna terminals on the rear panel, the signal enters the RF unit, in which relay switch (RL1) selects the signal from the desired antenna: ANT1 or ANT2. The signal is routed through a low-pass filter with a cutoff frequency of 30MHz, a 20dB attenuator (RL2), and a 10dB attenuator (RL3), to a ten-element bandpass filter. (The two bands below 1.6MHz are defined by low-pass filters.) Each bandpass filter element has the same configuration as in the TS-940, but in bands where there is ample bandwidth, a fixed inductance is used. There is no need to adjust the impedance at the output of the bandpass filter because automatic gain control is not accomplished using a PIN diode. The signal is therefore taken from the bandpass filter through a high impedance and matched directly to the RF amplifier (Q1). In the 0.5 MHz to 1.6MHz band, the signal passes through a three-stage trap filter that removes interference from broadcast-band transmission.

- Note:** Trap 1 L12 (0.39 $\mu\text{H}$ ) x C35 (0.033 $\mu\text{F}$ ) = 1403kHz  
 Trap 2 L13 (1 $\mu\text{H}$ ) x C36 (0.033 $\mu\text{F}$ ) = 876kHz  
 Trap 3 L14 (2.2 $\mu\text{H}$ ) x C37 (0.033 $\mu\text{F}$ ) = 591kHz

In locations subject to interference, such as near high-power broadcasting stations, interference can be reduced or eliminated changing by the L or C constants of the traps to tune them to the interfering frequencies. The attenuation of the trap can be enhanced by increasing the L/C ratio (making L large and C small) without changing the trap frequency, but this has a gradually increasing effect on low bands in the 2MHz to 3MHz range.

The signal from the RF amplifier (consisting of Q1 and Q2 cascaded) passes through an IF trap (around L44) then converted to the first IF of 58.1125MHz by mixing with the VCO signal in the first mixer (Q3 and Q4). To assure a high intercept point, the output of the mixer passes through a grounded-gate push-pull amplifier (Q5 and Q6), and is then applied to the IF unit after correction for the loss generated in the MCF.

The configuration so far is basically the same as in the TS-940, except for the higher 58.1125MHz first IF.

Upon entering the IF unit, the signal passes through HF/VHF switch (D1 and D2), then through the 58.1125 MHz MCF (XF1) which narrows the bandwidth by approximately 20kHz/-6dB, and is then amplified by the first IF amplifier (Q1). Q1 acts with delayed automatic gain control: it operates with full gain up to antenna input voltages of 100 $\mu\text{V}$  to 150 $\mu\text{V}$  but reduces gain for higher inputs. The use of AGC in this stage keeps the input level of the second mixer, the one that saturates the fastest

# CIRCUIT DESCRIPTION

(causing clipping), at an appropriate level so that even large input signals such as S9 + 60dB are undistorted. The AGC delay results in quick suppression of internal noise in the small and medium input ranges, thereby improving the audible signal-to-noise ratio.

In the second mixer (Q4 and Q5), the signal from Q1 is mixed with the HET signal (49.2825kHz) from Q2 and Q3, which converts it to the second IF (8.83MHz). The HET signal is generated by a third-overtone crystal oscillator, X1. To cancel any drift in this signal by frequency control in the set as a whole, the signal is also sent to the main phase-locked loop in the PLL unit.

After the signal is converted to 8.83MHz, it is applied in parallel to the noise blanker gate (Q10) and to the third mixer (Q9). In the third mixer, the third local oscillator frequency (8.375MHz) generated by Q8 is injected to convert the 8.83MHz signal to 455kHz. The 455kHz signal is sent in parallel to the noise blanking circuit and to the FM IF section.

In modes other than FM, the signal leaving the noise blanking gate (Q10) is routed through a series of filters: first an approximately 6kHz/-6dB W filter (XF2), then an filter M2 (XF3), an filter M1 (optional), and filter N (optional), with amplifier (Q18, Q19, and Q20) between adjacent filter stages. After being narrowed to the required bandwidth by these filters, the signal is amplified by Q21 and Q22 and is detected by a link detector (D24 to D27) or AM detector (Q26).

In the FM mode, the output of the third mixer (Q9) passes through a ceramic filter (CF1) and is amplified by limiters IC5 and IC6, then is detected by a ceramic discriminator (L26).

After detection, the level and frequency characteristics of the signal are corrected by a separate preamplifier for each mode, and the output is selected by an analog CMOS switch (IC9). The selected signal passes through a notch circuit that functions automatically as a peak filter in the CW mode, then through (X59-3030-00), a squelch gate (X59-3040-00), a tone balance amplifier IC12, and the AF gain trimmer. It is then amplified by the AF power amplifier IC13.

## Series Connection of IF Filters

A major feature of the R-5000 is that the IF filters that determine the receiving bandwidth are not switched in parallel as in previous receivers but are arranged in series (or cascade).

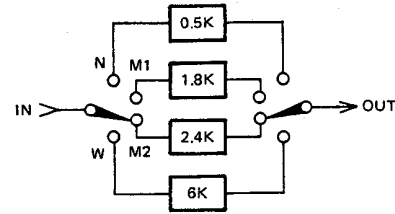

Fig. 3-1 IF filter connection in the conventional models

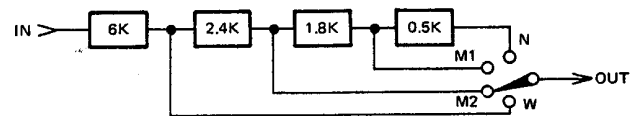

Fig. 3-2. IF filter connection in R-5000 (conceptual diagram)

Filters with passbands wider than the desired receiving bandwidth all pass the signal without attenuating it; the width of the passband is determined by the narrowest filter used; the other filters do not cause any changes or undesirable effects. At offsets of greater than a few kilohertz, however, the attenuation of each filter is added in. This and the careful circuit layout have resulted in a major improvement in guaranteed attenuation.

Passage through a number of narrow-band filters adds a group delay, but in practice the narrowest filter exerts the controlling influence, so there is no major change. The advantage of this type of layout was demonstrated, although in a different way, by the dual filter system of the TS-830 and TS-940.

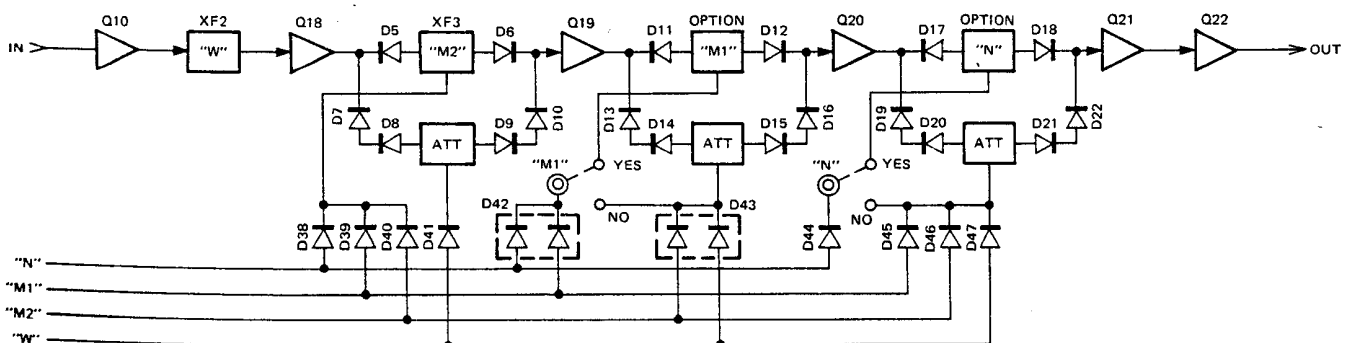

Fig. 4 IF filter connection

## CIRCUIT DESCRIPTION

The SELECTIVITY switch offers a choice of four receiving bandwidths: N, M1, M2, and W. In the AUTO position, these are selected automatically according to the signal mode as follows:

MODE	SELECTIVITY
USB, LSB	M2
CW	N
AM	W
FSK	N

**Table 2 SELECTIVITY responds each auto mode**

The SELECTIVITY switch does not function in the FM mode, so the set operates with a fixed FM bandwidth.

The M1 and N filters are optional. YES/NO jumpers in the IF unit must be reset when these filters are installed. If an optional filter selected by the SELECTIVITY switch is not installed, the set automatically operates at the bandwidth of the next-wider installed filter. **Fig. 5** shows the circuits associated with the SELECTIVITY switch.

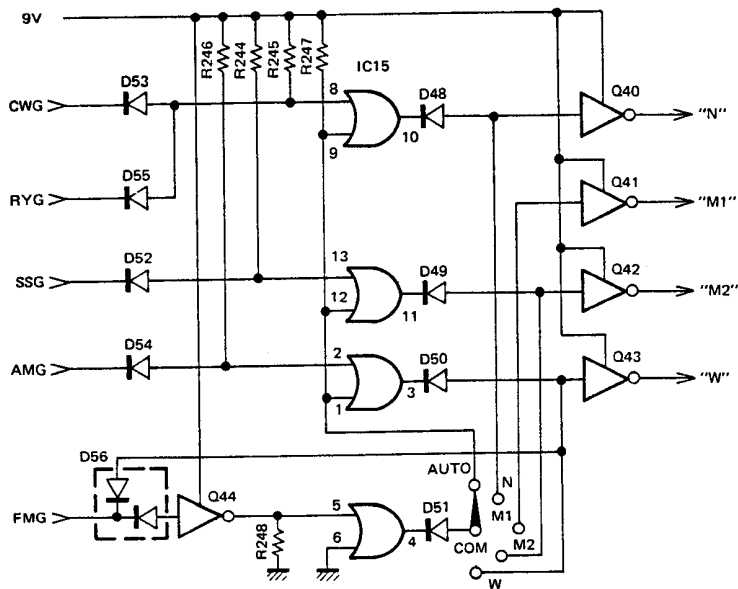

**Fig. 5 SELECTIVITY switch peripheral circuit**

### Noise Blanking (NB)

The noise blanker is basically the same as the one used in previous models. A particular feature is the NB2 position that stresses "woodpecker" blanking. The noise blanking level can be controlled from the front panel for maximum effectiveness.

Noise blanking is performed at the second IF (8.83 MHz) of the SSB signal system, but the NB noise amplifier operates at 455kHz, the third IF of the FM mode. If two 8.83MHz high-gain amplifiers were mounted on the same board, inadequate isolation between them would have the same result as inadequate filtering by the SSB IF filters, and the selectivity characteristic would be impaired. For this reason, the frequency of the NB noise amplifier is different from the frequency of the main SSB signal system.

The NB noise amplifier uses MOS-FET element that provide a wide AGC dynamic range and suppress inter-modulation distortion and unwanted noise blanking triggered by strong adjacent-channel signals.

Other models used diode switching for the noise blanking gate, but the R-5000 switches a MOS-FET amplifier (Q10) on and off to gate noise to blanking—this matches impedances of the preceding and following filters and other circuits to obtain a better overall gain distribution. When on, the gate itself has gain. Gating is fast enough to pose no problems for noise blanking, and an on/off transconductance ratio of 70dB or above is guaranteed.

The circuit in **Fig. 6** generates the noise blanking gate control pulse.

Due to the effect of automatic gain control in the NB noise amplifier, application of an unmodulated carrier generates a signal voltage of approximately 0.6V at point A.

A input of an AM voice signal gives a maximum of about 1.3V, and SSB input gives a maximum of 2V. When fast impulse noise is applied, however, the AGC tracking delay allows a momentary voltage of 3V to 5V. The emitter of Q15 is connected to a circuit consisting of R67, R68, Q25, R69, the NB LEVEL potentiometer control, and the NB switch. When the NB switch is OFF, a voltage of approximately 6.1V is added; when the NB switch is ON, a voltage of 0.3V to 2.6V is added, depending on the position of the NB LEVEL control. When the voltage at point A rises 0.6V above the voltage of the Q15 emitter, Q15 switches ON. Since point B is coupled to ground, Q16 switches ON, Q17 switches on, and NB gate Q10 switches OFF.

## CIRCUIT DESCRIPTION

Discrimination between signal and noise by observation of the voltage at point A depends on the mode as described above and on the strength of the signal, the presence of interference, and the type of noise. The NB LEVEL control provides an extremely effective means of keeping the optimum noise separation and switching threshold voltage set, but if NB LEVEL is turned up too high, noise blanking will be triggered by peaks in the voice signal, so this control must be used with care.

When NB2 is OFF, Q15, Q16, and Q17 all switch ON and OFF simultaneously; but when NB2 is ON, the NB2 end of resistor R71 becomes open so that C56 extends the blanking state by about 7ms. This makes the noise blanker effective against almost any type of "woodpecker" noise. For other types of woodpecker noise and for certain propagation conditions, however, the effectiveness is somewhat reduced.

Q25 is a protection switch that minimizes the break in the received signal when NB2 is switched ON by mistake for non-woodpecker noise. In the TS-930 and TS-940, a circuit counted the period of the blanking pulse and blanking was automatically inhibited in the case of operator error, but the R-5000 has a simplified circuit that detects operator errors from abnormalities in the receiver output tone.

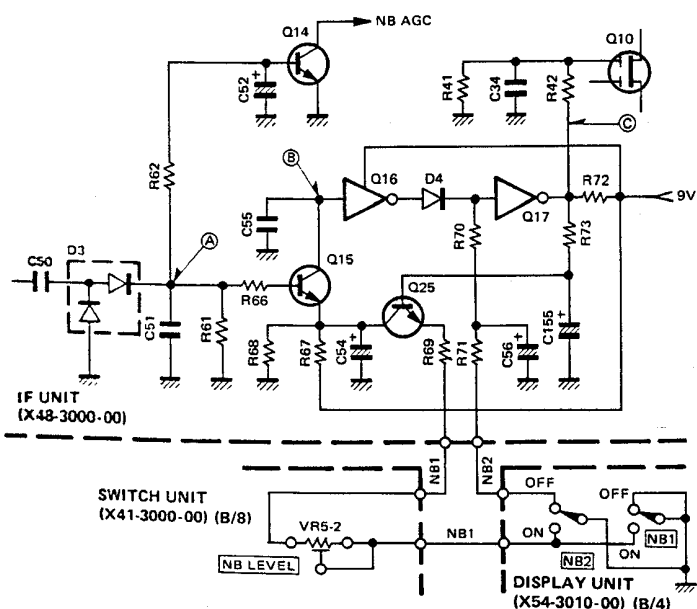

Fig. 6 NB gate control pulse performing circuit

### Notch Circuit

The R-5000 has an audio notch filter. In the CW mode this is automatically switched over to a peak filter that mainly blocks the high audio frequencies for CW reception with a good signal-to-noise ratio. The notch/peak frequency can be varied continuously from 450Hz to 3kHz by the NOTCH control.

A notch filter with a sharp cut-off may represent a high level of audio filter engineering, but in practice it can be difficult to use because the notch point is too hard to locate. Accordingly, this notch filter has a comparatively broad characteristic.

The circuit is basically a bridge-T active filter acting as a variable bandpass filter (peak filter). The notch characteristic is synthesized according to the input and output signal sum. Using a modular configuration with chip components improves stability. As a result, the effective notch attenuation is 30dB to 40dB throughout the variable range.

### NOTCH (X59-3030-00)

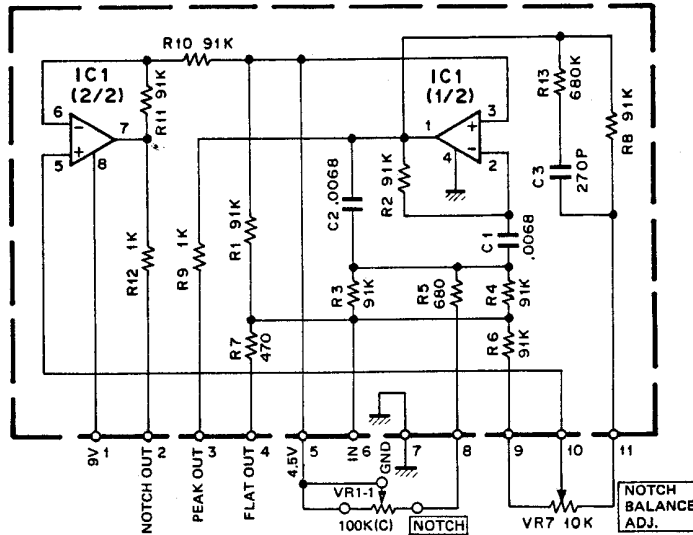

Fig. 7 NOTCH circuit

# R-5000

## CIRCUIT DESCRIPTION

### AGC and S Meter Circuits

In the R-5000, automatic gain control is implemented in four MOS-FET stages located in the first IF amplifier (58.1124MHz, IF unit, Q1) and second IF amplifier (8.83 MHz, IF unit, Q19, Q21, Q22). In the first IF amplifier, the automatic gain control is delayed. This guarantees an AGC range of at least 90dB for an antenna input voltage of  $1\mu\text{V}$  to 20mV and up. There are four AGC time constants: an independent slow and fast in both the SSB and AM systems, providing stable, undistorted reception.

Fig. 8 shows the R-5000's AGC circuit. The signal taken from Q22 in the last IF amplifier at 8.83MHz is buffered by Q24 then detected by the AGC detector D28; its DC component drives AGC amplifier (Q27). The time-constant circuit has four time constants, as explained above, which are selected by an analog C-MOS switch according to the current mode and the position of the AGC switch. (SLOW or FAST). In the FM mode, the SSB-fast time constant is used regardless of the position of the AGC switch. This is done not because automatic gain control operates in the FM mode but to adjust the response of the S meter.

The voltage from the time-constant circuit is applied to the S meter module unit and drives the AGC line through a voltage buffer (Q5) and the AGC drivers (Q3 and Q4). The reason for the Q5 voltage buffer is to provide a high-impedance input to the time-constant circuit and for temperature compensation of S meter driver Q2 (to prevent zero-point temperature drift of the S meter). The AGC drivers (Q3 and Q4) have the same complementary Darlington configuration as used in the TS-930 and TS-940, which reduces the impedance of AGC line, improve the transient tracking characteristic, and enables the emitter current of Q3 to be controlled by an external muting signal, so that muting can be created by block-biasing the IF amplifier via the AGC line. This method of block biasing using the AGC line was also used in the TS-930 and TS-940 as part of the full-breaking circuit. It enables muting to be switched ON and OFF quickly and smoothly, with no abnormal gain increase during transient switchover.

On the controlled side, fast AGC is fed back to Q21 and Q22 with no attack delay, but the feedback to Q19 is somewhat slowed, in consideration of loop stability, to provide for narrow-band filtering (filter options N and M1) in the loop.

The source voltage of voltage buffer Q5 is detected and applied to comparator (IC4) which generates the delayed AGC voltage for Q1 in the first IF amplifier. If the AGC dynamic range is ignored, the best signal-to-noise ratio results from having automatic gain control act on the latest possible stage, for rapid suppression of the internal noise generated as the antenna input voltage increases. To prevent saturation (clipping distortion) due to large input and to obtain a wide AGC dynamic range, level control must be performed at as early a stage as possible. To satisfy both these requirements at once, the R-5000 uses delayed automatic gain control. Specifically, the first IF amplifier (Q1) operates at full gain at antenna input voltages from  $100\mu\text{V}$  to  $150\mu\text{V}$ , but at diminishing gain at higher voltages. Due to the large number of narrow-band filters in the loop, however, the AGC attack speed is set to a low value; since the recovery speed is also slow, no block bias is added to Q1 from the external muting signal.

As indicated by the fact that the S meter can be read in microvolts, the S meter of the R-5000 is superior in accuracy and linearity to previous models in the 1.8MHz to 30MHz range. The same S meter circuit is used in all modes, so the meter deflects by the same amount in response to the same incoming signal level in any receiving mode. Even in the FM mode, the S meter deflects according to the AGC voltage, just as in the SSB system.

The SSB IF circuit always generates an AGC signal which drives the S meter. For that reason, the first IF amplifier (Q1), shared by the FM and SSB systems, is under automatic gain control even in the FM mode but, since the automatic gain control is delayed and applies only to large antenna input, it has no actual effect on the FM signal.

## CIRCUIT DESCRIPTION

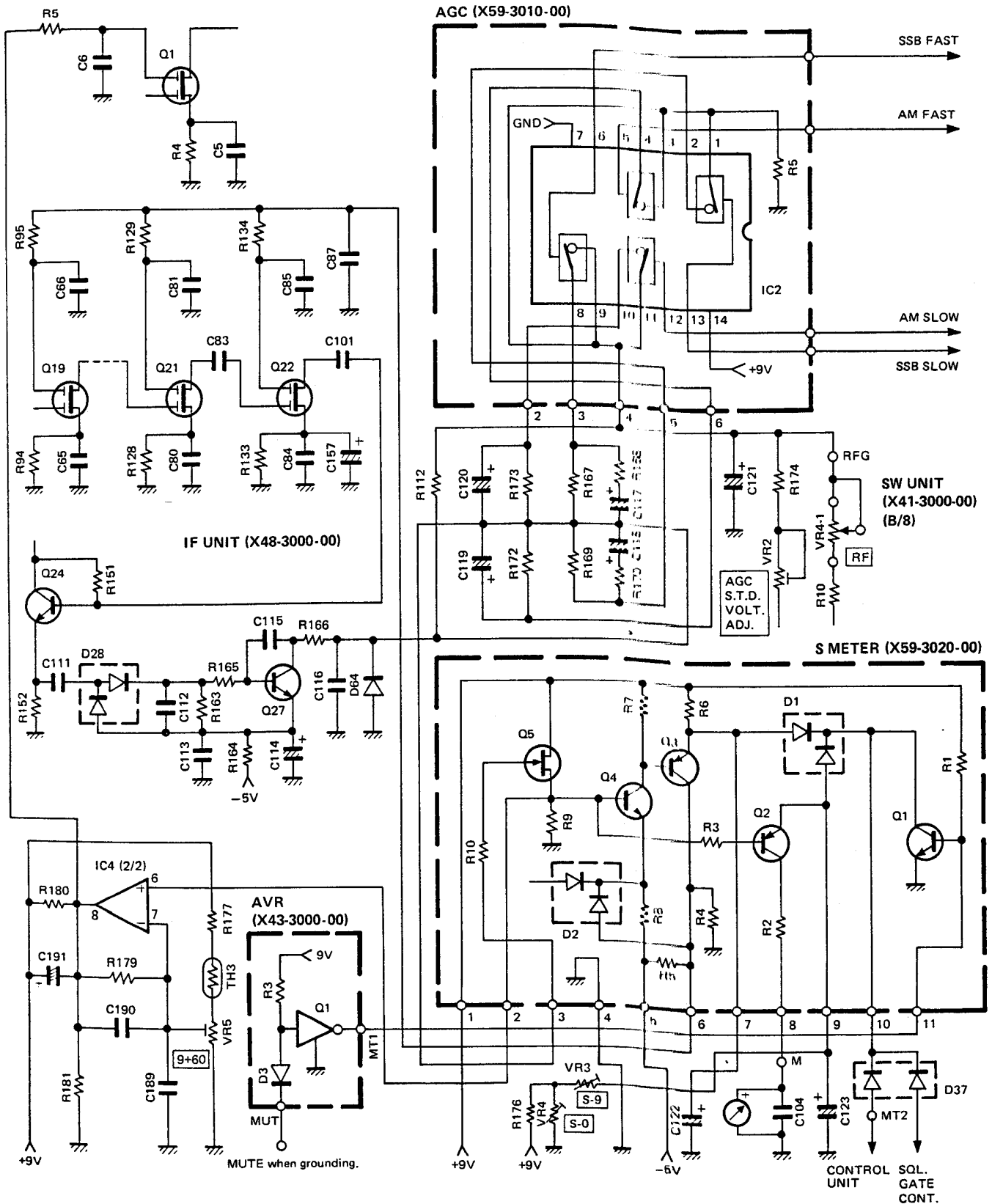

Fig. 8 AGC circuit

## CIRCUIT DESCRIPTION

### Muting Circuit

The R-5000 is designed to be used in combination with a separate transmitter, so it has been provided with an external muting control connector that can be used to halt reception during transmission. When the REMOTE connector pin on the rear panel is connected to chassis ground, the R-5000 is muted.

1. The second mixer (Q4, Q5 in the IF unit) is block-biased over the BLK line from the microprocessor.
2. The second IF amplifier (IF units, Q19, Q21, Q22) is block-biased through the AGC line.
3. The S meter drive circuit is switched OFF. The S meter does not deflect when the RF GAIN control is turned counterclockwise.
4. The squelch gate is switched OFF, the audio is muted, and the BUSY lamp lights.
5. ENT, SCAN, SCROLL, and other operations are halted and cleared.

The electrical states of the muting connector on the rear panel are as follows

Voltage : about + 4.8V when open

Current : about 0.4mA when grounded

Accordingly, if the residual voltage is roughly 0.2V or less when muting is switched ON, a transistor switch can be used to control the muting input.

### Analog switch

The R-5000 uses analog C-MOS switches to select the AGC time constant, the detected audio signal, the filter characteristic (notch, peak, or flat), and for squelch gating. These switches have the following advantages:

1. High duty factor
2. Low ON state resistance
3. Little generated distortion and noise
4. Only slight clipping the control input
5. Very low control power

They also simplify the Control circuits and reduce the length of the signal lines.

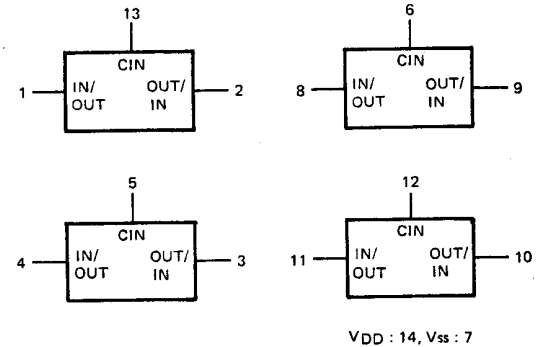

Fig. 9 Analog switch TC4066BP block diagram

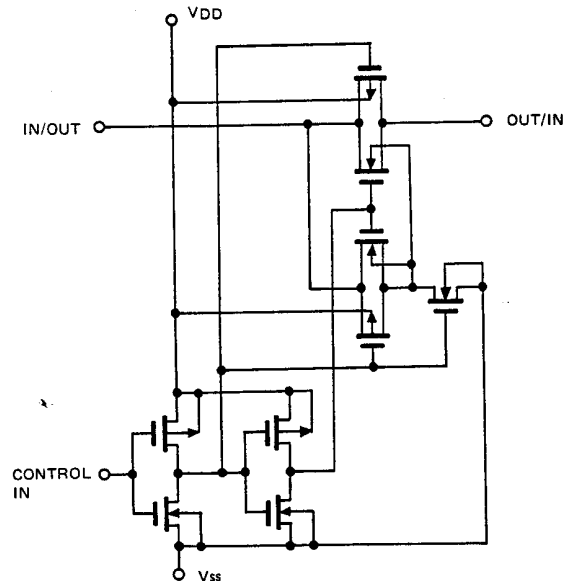

Fig. 10 Analog switch TC4066BP equivalent circuit

### PLL Circuit

The PLL circuit of the R-5000 consists of five phase-locked loops that provide tuning in 10Hz steps from 30kHz to 30MHz in the HF band with a base frequency of 18MHz (from 108MHz to 174MHz if the VHF converter option is installed).

The BFO and HET frequencies are applied to the phase-locked loops to perform an IF shift. The division ratio data sent to the phase-locked loops is controlled by the microprocessor. Except in the FM mode, one-crystal frequency control is performed, the signal phase being compared with a reference frequency generated by an oscillator.

Fig. 11 is a block diagram of the PLL circuit.

## CIRCUIT DESCRIPTION

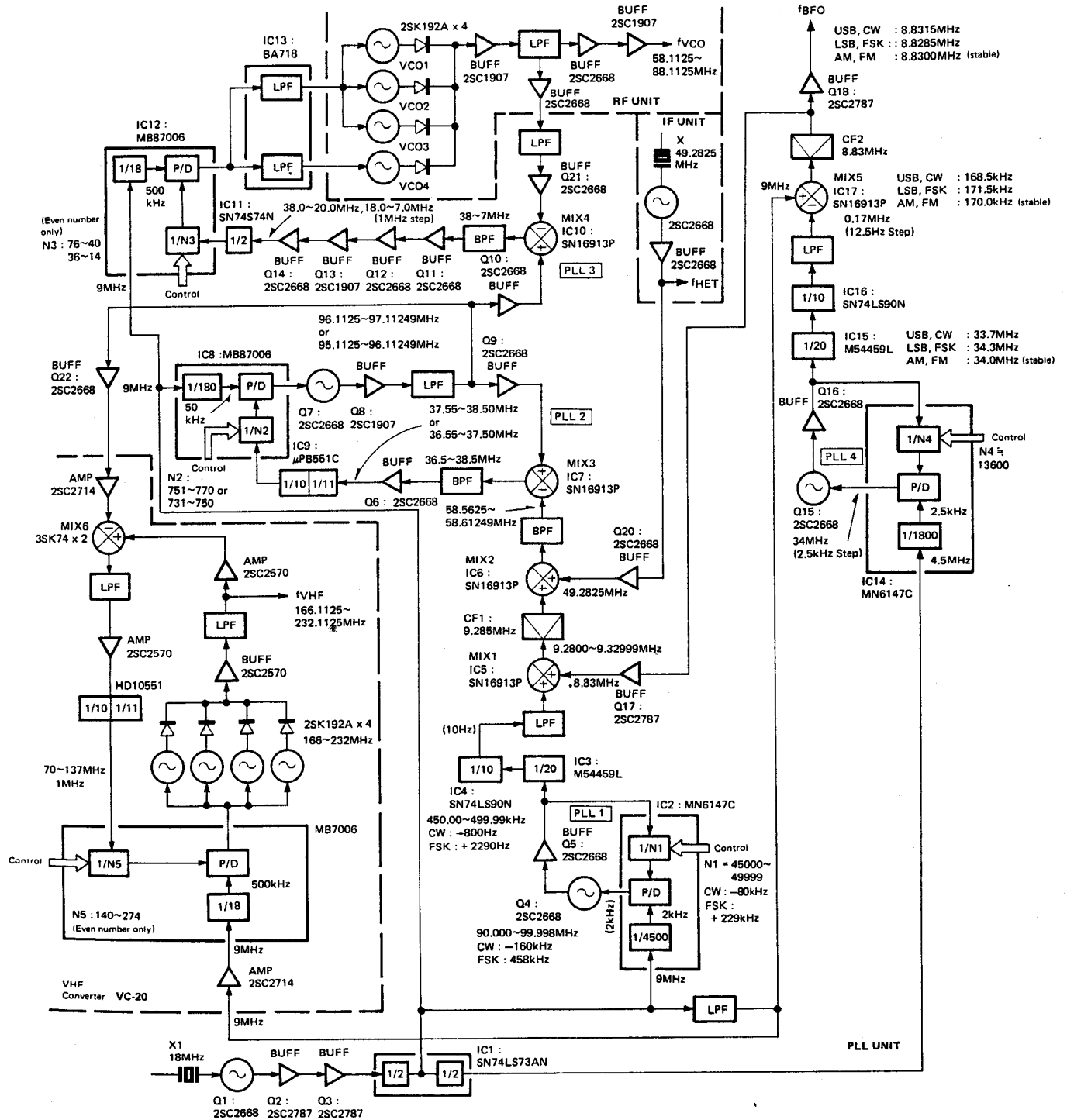

Fig. 11 PLL circuit block diagram

## CIRCUIT DESCRIPTION

### • Reference oscillator circuit

The basic standard signal used in the R-5000 (f<sub>STD</sub>) is generated by an 18MHz crystal oscillator X1 and Q1 : 2SC2668. It is buffered by Q2 and Q3 : 2SC2787, then divided by IC1 : SN74LS73AN to produce the basic reference frequencies of 1/2 f<sub>STD</sub> and 1/4 f<sub>STD</sub> used by the phase-locked loops.

### • PLL4

PLL4 operates on the BFO signal, and its main component is IC14 : MN6147C. PLL4 also performs fine frequency adjustments such as IF shifting of the detected signal and carrier point correction.

The basic reference frequency 1/4 f<sub>STD</sub> is divided by 1800 in the reference frequency prescaler (IC14) to generate form the 2.5kHz reference frequency. The signal generated by VCO4 at Q15 : 2SC2668 is buffered by Q16 : 2SC2668 and returned to IC14, which divides it by according to the ratio sent from the Control unit (DA0 to DA3, CL4), and compares its phase with the comparison reference described above. The phase difference is returned to VCO4 forming the BFO phase-locked loop. When PLL4 is locked, the VCO4 frequency is approximately 34MHz, but varies depending on the mode, IF shift, and carrier point correction.

The output from PLL4 is divided by 20 at IC15 : M54459L, then by 10 in IC16 : SN74LS90N. After filtering by a low-pass filter, it is mixed with the 1/2 f<sub>STD</sub> signal of 9MHz, passed through CF2 (8.83MHz), and buffered by Q18 : 2SC2787, then supplied to the IF unit as the BFO signal.

The second BFO signal is buffered by Q17 : 2SC2787 and enters the mixer in the main loop, where it drives the digital variable-frequency oscillator (VFO). As a result, even if the BFO frequency is varied, the operating frequency does not change. Mode switching (USB, LSB, etc.), IF shifting, and carrier point fine adjustment are performed. The IF shift is a shift of ±1kHz during SSB, CW, and FSK reception. The carrier point frequency can be adjusted by about ±300Hz.

The frequency relationships of PLL4 are given below:

$$f_{VCO4} = \frac{1}{1800} \cdot \frac{1}{4} f_{STD} \cdot N4$$

$$f_{BFO} = \frac{1}{2} f_{STD} - \frac{1}{200} f_{VCO4} = \left( \frac{1}{2} - \frac{N4}{1440000} \right) f_{STD}$$

### • PLL1

PLL1 forms the lowest-order decade of the digital VFO, corresponding to a bandwidth of 50kHz.

Its main component is IC2 : MN4617C. The VCO at Q4 : 2SC2668 locks in the range from 90.000MHz to 99.998MHz (89.840MHz to 99.838MHz in the CW mode, 90.458MHz to 100.456MHz in the FSK mode). The 9MHz 1/2 f<sub>STD</sub> signal is applied at pin 3 of IC2, and is divided by 4500 internally to form the 2kHz reference signal.

The output of the VCO passes through the buffer amplifier Q5 : 2SC2668 and is applied at pin 16 of IC2, which divides it internally by a factor of N1. A phase comparator compares it with the 2kHz reference signal, the VCO frequency is then locked in 2kHz steps. The division ratio N1 is sent as division data (DA0 to DA3, CL1) from the microprocessor in 5000 steps (45000 to 49999) corresponding to frequencies from 0.00kHz to 49.99kHz. The division ratio N1 is corrected according to the mode.

During CW reception, to obtain 800Hz beats at the operating frequency reading, N1 is shifted by 80 (44920 to 49919). During FSK reception, to equalize the space frequency and displayed frequency, N1 is shifted by 229 (45229 to 50228).

The PLL1 output is divided by 20 at IC3 : M54459L, then by 10 in IC4 : SN74LS90N and passes through a low-pass filter to pin 5 of IC5 : SN16913P in the first mixer (MIX1), where it is mixed with the signal produced by PLL4. After passing through CF1, it emerges in 10Hz steps from 9.2800MHz to 9.32999MHz, and is applied to pin 5 of IC6 : SN16913P of the second mixer (MIX2).

The frequency relationships of PLL1 are given by the following equation:

$$f_{VCO1} = \frac{1}{4500} \cdot \frac{1}{2} f_{STD} \cdot N1 = \frac{N1}{9000} f_{STD}$$

### • PLL2

PLL2 is also one of the digital VFO phase-locked loops, corresponding to the 1MHz bandwidth. It has a pulse-swallow configuration and consists of IC8 : MB87006 and IC9 : μPB551C.

The division ratio data are arranged to shift the frequency range covered by PLL2 and PLL3, and by PLL2 and PLL5 (in the VHF converter), so that the frequency ranges of the VCOs in the PLL unit are not received as internal beats. PLL2 therefore has two frequency ranges, and VCO2 is variable within a range of 2MHz.

The in or sign by 50 250 cor lo sig is 2 v rat f th dr th P t

## CIRCUIT DESCRIPTION

The oscillation frequency of VCO2 in the locked state is in one of the two ranges 96.1125MHz to 97.11249MHz or 95.1125MHz to 96.11249MHz. The basic reference signal  $1/2 f_{STD}$  is applied to pin 1 of IC8 and divided by 180 by the reference divider in IC8 to produce the 50kHz reference signal. The signal produced at Q7 : 2SC2668 in VCO2 passes through a buffer amplifier consisting of Q8 : 2SC1907 and Q9 : 2SC2668 and a low-pass filter, then is mixed with the low-order decade signal in the third mixer (MIX3). The resulting signal is filtered by a bandpass filter and buffered by Q6 : 2SC2668, then fed back to the pulse-swallow prescaler IC9 where it is divided by an amount depending on the division ratio data N2 from the Control unit (SO, SCK, CL2).

Next its phase is compared with that of the 50kHz reference signal. In forming the low-order decade signal, the VCO1 signal is divided by 200, and to cancel the drift of the BFO and HET signals,  $f_{HET}$  and  $f_{BFO}$  are fed into the main loop early.

Considerations involving the prescaler and mixer on the signal path result in the frequency relationships in PLL2 as follows:

$$\begin{aligned} f_{VCO2} &= \text{PLL2 IF} + f_{HET} + f_{BFO} + \frac{1}{200} f_{VCO1} \\ &= \frac{1}{180} \cdot \frac{1}{2} f_{STD} \cdot N2 + f_{HET} + \left( \frac{1}{2} - \frac{N4}{1440000} \right) f_{STD} \\ &\quad + \frac{1}{200} \cdot \frac{N1}{9000} f_{STD} \\ &= \left( \frac{N1}{1800000} + \frac{N2}{360} - \frac{N4}{1440000} + \frac{1}{2} \right) f_{STD} + f_{HET} \end{aligned}$$

### • PLL3

PLL3 is the last phase-locked loop in the HF band. Its principal component is IC12 : MB87006. VCO3, which is located in the RF unit, is divided into four bands, one for each frequency range, one of which is selected by a signal that depends on the band data (RB0 to RB3) from the Control unit.

The basic reference signal  $1/2 f_{STD}$  is applied to pin 1 of IC12 and divided by 18 to create a 500kHz reference signal. The VCO3 output selected according to the received frequency is buffered by Q12 : 2SC1907 and Q15 : 2SC2668 in the RF unit, then returned as the VFO signal to the PLL unit. After buffering by Q21 : 2SC2668 in the PLL unit, it is mixed with low-order decade signal VCO2 and passed through a bandpass filter and buffer amplifier consisting of Q11, Q12 and Q14 : 2SC2668 and Q13 : 2SC1907, then divided by 2 in IC11 : SN74S74N and returned to IC12.

Here it is divided according to division ratio data N3 from the Control unit (SO, SCK, and LE1) and its phase is compared with that of the 500kHz comparison reference. VCO3 is controlled according to the error voltage to complete the PLL3 loop.

The frequencies in PLL3 are as follows:

$$\begin{aligned} f_{VCO3} &= f_{VCO} = f_{VCO2} - \text{PLL3 IF} \\ &= \left( \frac{N1}{1800000} + \frac{N2}{360} - \frac{N4}{1440000} + \frac{1}{2} \right) f_{STD} + f_{HET} \\ &\quad - \frac{1}{18} \cdot \frac{1}{2} f_{STD} \cdot N3 \\ &= \left( \frac{N1}{1800000} + \frac{N2}{360} - \frac{N3}{36} - \frac{N4}{1440000} + \frac{1}{2} \right) \\ &\quad f_{STD} + f_{HET} \end{aligned}$$

### • PLL5

This phase-locked loop covers the VHF band and is part of the VHF converter option. VCO5 is also divided according to the received frequency into four bands, one of which is selected according to the band data (RB0 to RB3) from the Control unit.

The IC package of this phase-locked loop, IC101 : MB87006 on the VHF converter board, receives  $1/2 f_{STD}$  at pin 1, which is divided by 18 to create the 500kHz comparison reference signal.

The output signal from VCO5 passes through a low-pass filter, buffer, and amplifier (Q111 and Q100 : 2SC2570) then is mixed with low-order PLL signal VCO2. Then it is filtered by another low-pass filter and buffered by Q104 : 2SC2570, then applied to the pulse-swallow prescaler IC100 : HD10551. IC101 receives division ratio data N5 from the Control unit (SO, SCK, and LE2), according to which it divides the input signal while switching the swallow prescaler through the modulus control pin, and performs a phase comparison with the 500kHz comparison signal. Low-order decade signal VCO2 covers the received-frequency range from 108MHz to 174MHz in 10Hz steps, the same as in the HF band.

The frequencies in PLL5 are given as follows:

$$\begin{aligned} f_{VCO5} &= f_{VHF} = f_{VCO2} + \text{PLL5 IF} \\ &= \left( \frac{N1}{1800000} + \frac{N2}{360} - \frac{N4}{1440000} + \frac{1}{2} \right) f_{STD} + f_{HET} \\ &\quad + \frac{1}{18} \cdot \frac{1}{2} f_{STD} \cdot N5 \\ &= \left( \frac{N1}{1800000} + \frac{N2}{360} - \frac{N4}{1440000} + \frac{N5}{36} + \frac{1}{2} \right) f_{STD} \\ &\quad + f_{HET} \end{aligned}$$

## CIRCUIT DESCRIPTION

### • Unlocked signals

If even one of the phase-locked loops becomes unlocked, the displayed frequency would not agree with the received frequency. In unlocked operation, a signal is sent to the Control unit, which blanks the display to warn the user of the unlock condition.

From PLL2 on down the HF and VHF bands share the same phase-locked loops, so three analog signals are output, corresponding to PLL3 (HF), PLL5 (VHF), and PLL1 + PLL2 + PLL4 (low-order decades). If the PLL3 unlock signal (HUL) and low-order unlocked signal (ULK) are simultaneously active in the HF band or if the PLL5 unlock signal (VUL) and low-order unlock signal

(ULK) are simultaneously active in the VHF band, the Control unit concludes that the PLL system is correctly locked.

The VUL signal is used to detect the presence or absence of the converter option. When the converter is not installed or is malfunctioning, VUL does not become active, so operation is unconditionally shifted to the HF band.

### • MKR signal

The 500kHz comparison reference signal is always sent output from pin 13 of IC12, so this signal is used as the marker signal for 500kHz calibration.

Name	Use	IC components	Reference signal	Comparison frequency	R: Range of N	VCO frequency range	Test point	Unlock signal
PLL1	Digital VFO least significant digit	IC2 : MN6147C	1/2 fSTD	2kHz	45000~49999 (CW : 44920~49919) (FSK : 45229~50228)	90.0~99.998MHz (CW : 89.83~99.838MHz) (FSK : 90.458~100.456MHz)	Pin 3 : Reference signal 1/2 fSTD Pin 16 : VCO1 return signal, approx. 90~100MHz when locked.	Pin 2 : "H" when locked.
PLL2	Digital VCO middle digit	IC8 : MB87006 IC9 : $\mu$ PB551C (Pulse swallow)	1/2 fSTD	50kHz	751~770 or 731~750	96.1125~97.11249MHz or 95.1125~96.11249MHz  PLL2 IF 37.55~38.50MHz or 36.55~37.50MHz (In 50kHz steps)	Pin 1 : Reference signal 1/2 fSTD Pin 13 : Comparison signal 50kHz IC9, pin 2 : PLL2 IF signal	Pin 7 : "H" when locked.
PLL3	Digital VCO VHF band most significant digit	IC12 : MB87006	1/2 fSTD	500kHz	76~40 and 36~14 (Even number only)	58.1425~88.11245MHz PLL3 IF 38.0~20.0MHz 18.0~7.0MHz (In 1MHz steps)	Pin 1 : Reference signal 1/2 fSTD Pin 13 : Comparison signal 500kHz Pin 8 : PLL3 IF signal	Pin 7 : "H" when locked. PLL unit connector 5 , HUL terminal : "L" when locked.
PLL4	BFO signal	IC14 : MN6147C	1/4 fSTD	2.5kHz	Logical IF shift center value USB, CW : 13480 LSB, FSK : 13720 AF, FM : 13600 Varied by IF shift and carrier point compensation. 13209~13990	Logical IF shift center value USB, CW : 33.7MHz LSB, FSK : 34.3MHz AM, FM : 34.0MHz  33.0225~34.975MHz	Pin 3 : Reference signal 1/4 fSTD Pin 16 : VCO4 return signal, approx. 34MHz	Pin 2 : "H" when locked.
PLL5	Digital VFO VHF band most significant digit	VHF converter IC101 : MB87006 IC100 : HD10551 (Pulse swallow)	1/2 fSTD	500kHz	140~274 (Even number only)	166.1125~232.1125MHz PLL5 IF 70.0~137.0MHz (In 1MHz steps)	Pin 1 : Reference signal 1/2 fSTD Pin 13 : Comparison signal 500kHz Pin 8 : PLL5 IF signal	Pin 7 : "H" when locked. VHF converter connector 3 , VUL terminal : "L" when locked.

Table 3 PLLs summary

# CIRCUIT DESCRIPTION

## Digital Control

The digital section of the R-5000 has a multichip configuration consisting of a  $\mu$ PD7800G 8-bit microprocessor CPU, 16K-byte x 8-bit read-only memory (ROM), 2K-byte x 8-bit random-access memory (RAM), and two M5M82C55AP-5 universal C-MOS input-output ports. It also has an optional 8251 serial I/O port for interfacing with a personal computer. These components are connected

via a common data bus.

Fig. 12 is a block diagram of the control system. The integrated circuits are interfaced by an address bus, data bus, and control bus. Data flow is controlled by the microprocessor.

The digital control section consists of the Control unit (X53-3020-XX) and Display unit (X54-3010-00).

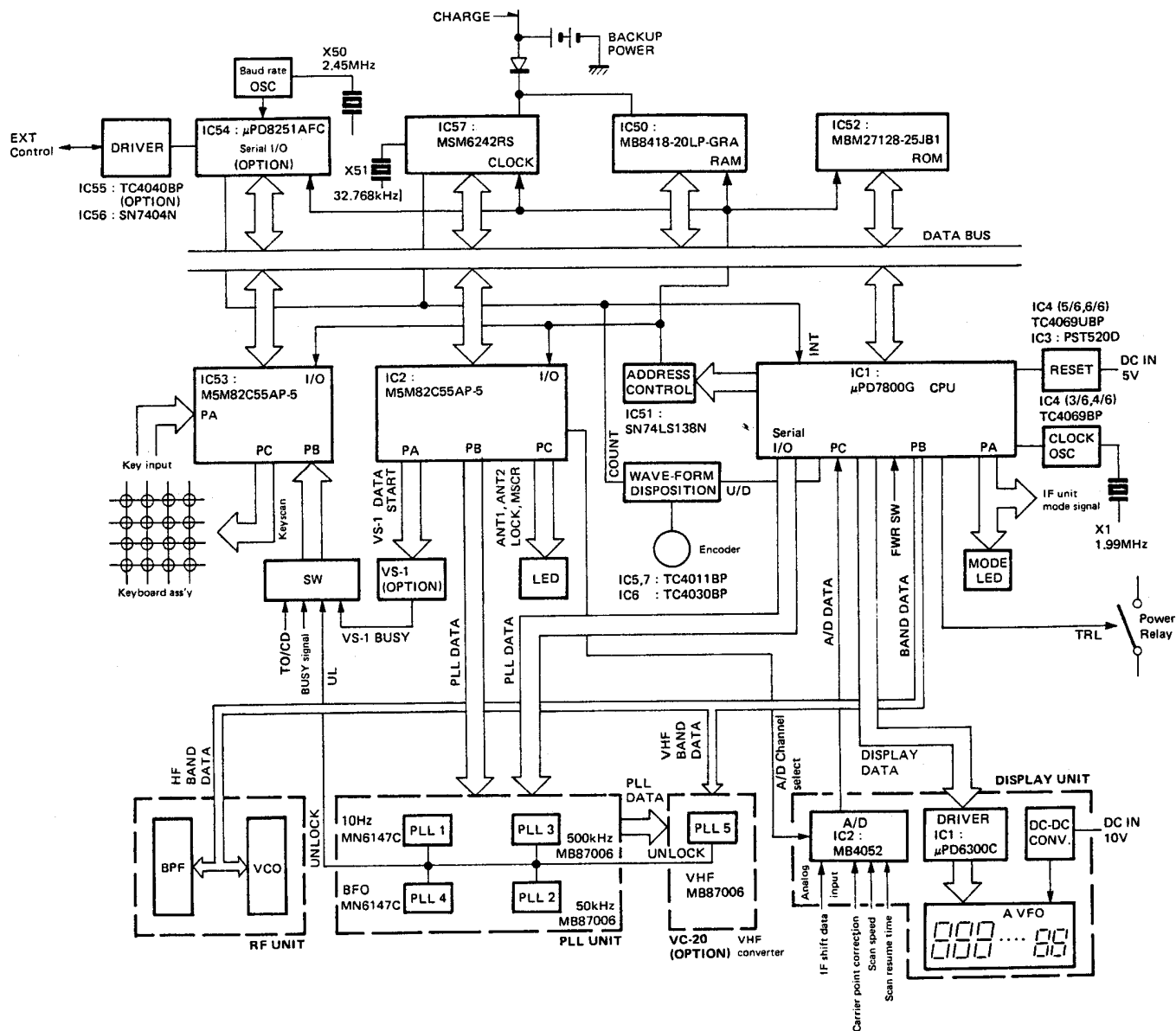

Fig. 12 Control circuit block diagram

## CIRCUIT DESCRIPTION

### ● Details of the Units

The control unit is a microcomputer incorporating a CPU, ROM, RAM, parallel I/O, serial I/O (optional), encoder waveform-shaping circuit, system reset circuit, system clock, and real-time clock.

The Display unit consists of a display data interface, A/D converter, fluorescent indicator tubes, an indicator driver, and a DC-DC converter.

The microcomputer section operates continuously as long as the set is plugged in, regardless of whether the power switch is ON or OFF. It also controls the display of time and runs the timer.

### ● Encoder Circuit

The encoder is an optical device that provides two count pulses 90° out of phase. In the Control unit, this two-phase signal is resolved into an up/down directional signal and count pulses that notify the microprocessor of the rotation of the encoder. The encoder has 250 slits, each slit giving rise to four count pulses so that one rotation of the encoder generates 1000 pulses.

Fig. 13 shows the encoder circuit, and Fig. 14 gives the timing chart.

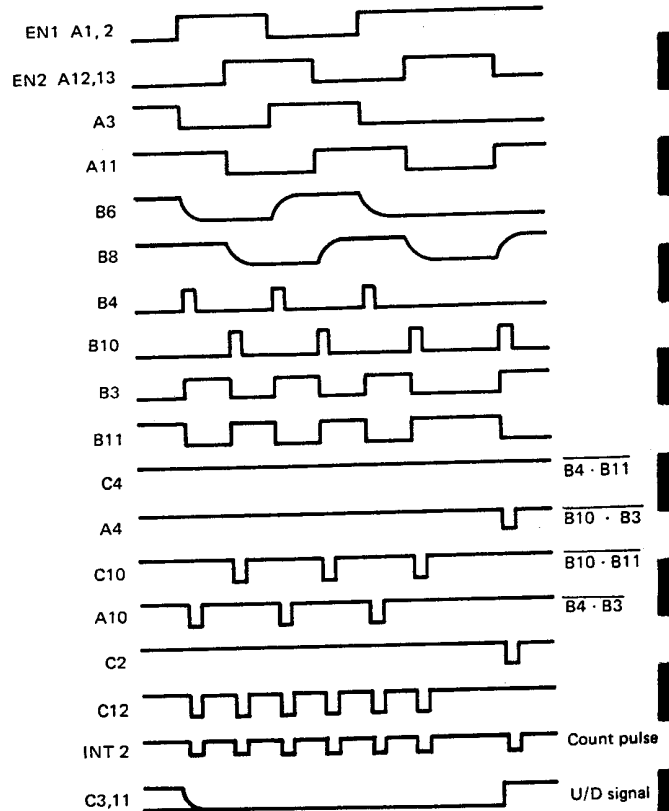

Fig. 14 Encoder timing chart

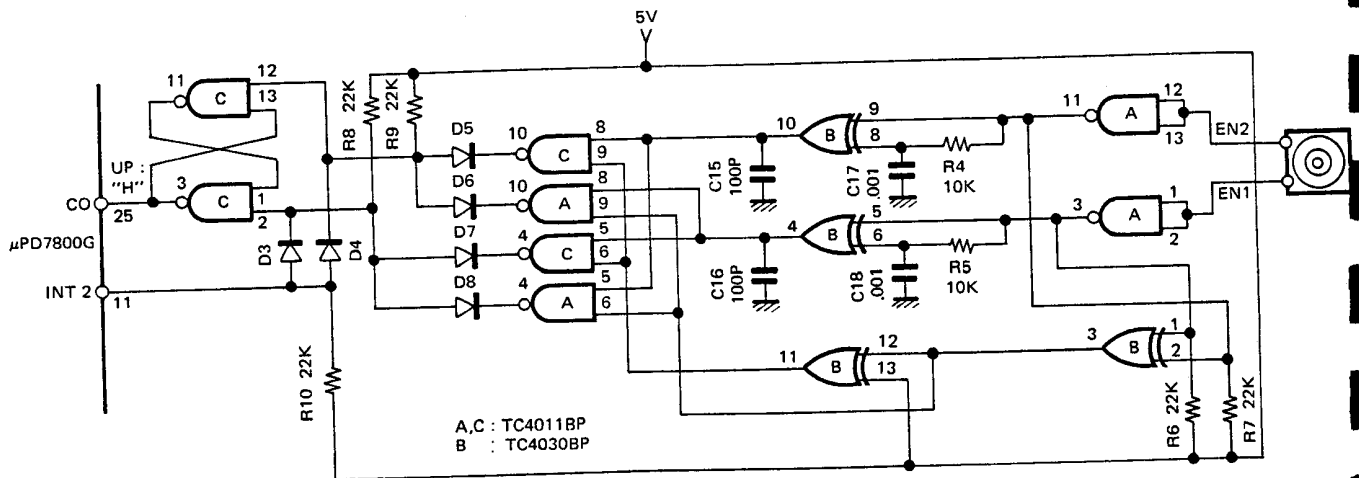

Fig. 13 Encoder waveform-shaping

## CIRCUIT DESCRIPTION

### ● System Clock and System Reset Circuits

The  $\mu$ PD7800G microprocessor requires a 2.00MHz system clock, which is generated by ceramic oscillator X1 and IC4 (3/6, 4/6). Since the system clock consists of square waves, it contains infinite high-frequency harmonics that cause internal beats, so the frequency is moved slightly down to 1.99MHz to avoid interference in the amateur band.

IC3 is the reset circuit. When the supply voltage is approximately 4.3V, it sends a reset signal to the microprocessor and I/O ports that halts them immediately. The reset signal is cleared when the supply voltage goes above 4.3V; after the time constant determined by R3 and C10, the microprocessor is initialized and begins running. (Fig. 15 is a schematic of IC3 and IC4 (3/6, 4/6); 7 Fig. 16 is a reset timing chart.)

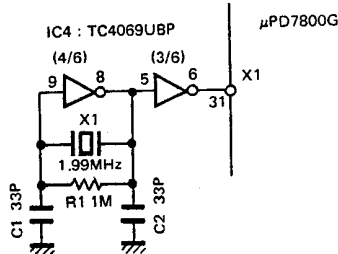

Fig. 15 System clock oscillation circuit

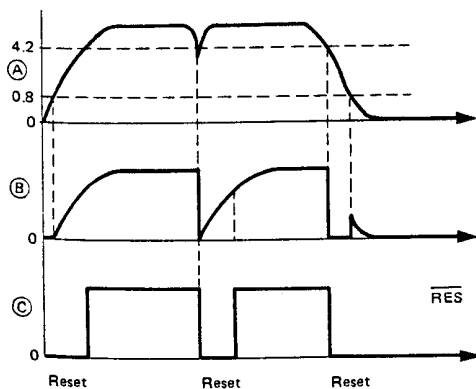
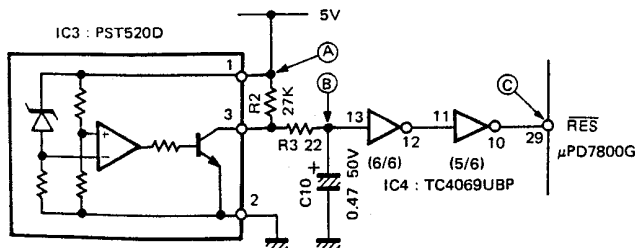

Fig. 16 Reset circuit and timing chart

### ● Address Control

The address signals (E0 to E15) from the microprocessor cannot be used directly to select chips; they must be decoded by IC51 : SN74LS138N to obtain a selection signal. IC51 has a 64K-byte memory area which is divided into eight 8K-byte blocks, one for each IC chip. Fig. 17 shows the address control circuits, and Fig. 18 is a memory map of the R-5000.

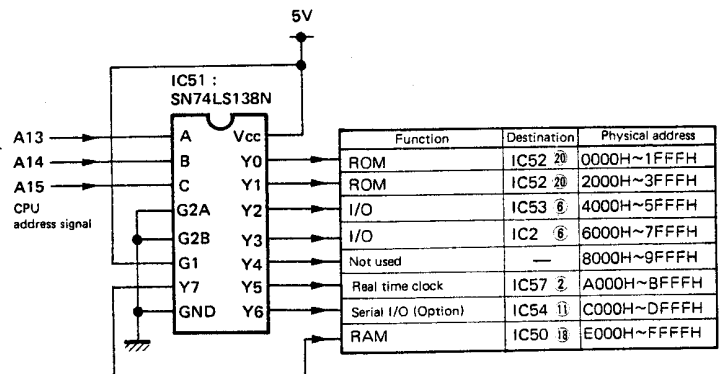

Fig. 17 Address control division

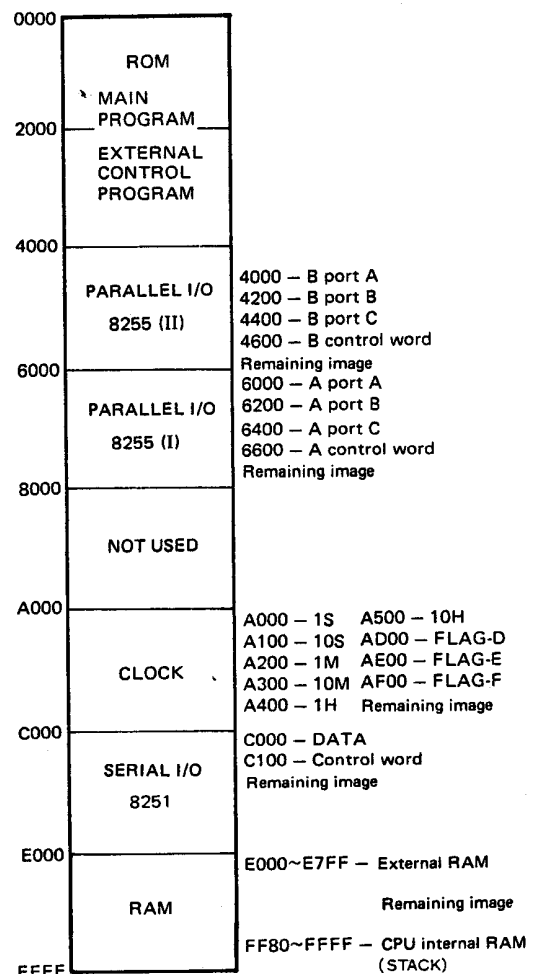

Fig. 18 Memory map

## CIRCUIT DESCRIPTION

### ● Real-Time Clock

IC57 is a single-chip real-time clock connected to a 32.768kHz crystal oscillator (X51). The microprocessor reads current time data from this clock chip and displays it as CLOCK1. The clock chip divides the 32.768kHz frequency by 512 to produce a 64Hz signal that it uses to flash the colon every 0.5s and to generate microprocessor interrupts to read the time at 1s. When CLOCK2 is set, the difference from CLOCK1 is calculated each time CLOCK1 changes to create the CLOCK2 signal.

### ● Display Drive Interface

A timer in the microprocessor generates an interrupt approximately every 1ms for sending display data to the  $\mu$ PD6300C display driver chip in the Display unit. The data is sent serially from the microprocessor at a rate of 1MHz, but is divided to 500kHz by IC3 before being

passed to the  $\mu$ PD6300C. The 13 digit, and the 7-segment signals are buffered by  $\mu$ PD6300. Dp is buffered by a transistor and the red characters are driven by 8V for intensity balance.

A total of 40 bits of display data is sent 8 bits at a time, followed by a negative enable pulse to latch the data in the  $\mu$ PD6300C and light the display.

The  $\mu$ PD6300C has a  $\overline{BI}$  pin that can easily be connected to a duty-control type of dimmer. In the R-5000, a 555 timer is used for duty control by a one-shot multivibrator on the latch pulse ( $\overline{LH}$ ). The  $\overline{BI}$  pin is high when the dimmer is OFF and receives a square wave with a duty ratio of approximately 20% when the dimmer is ON.

Fig. 19 shows the Display circuits.

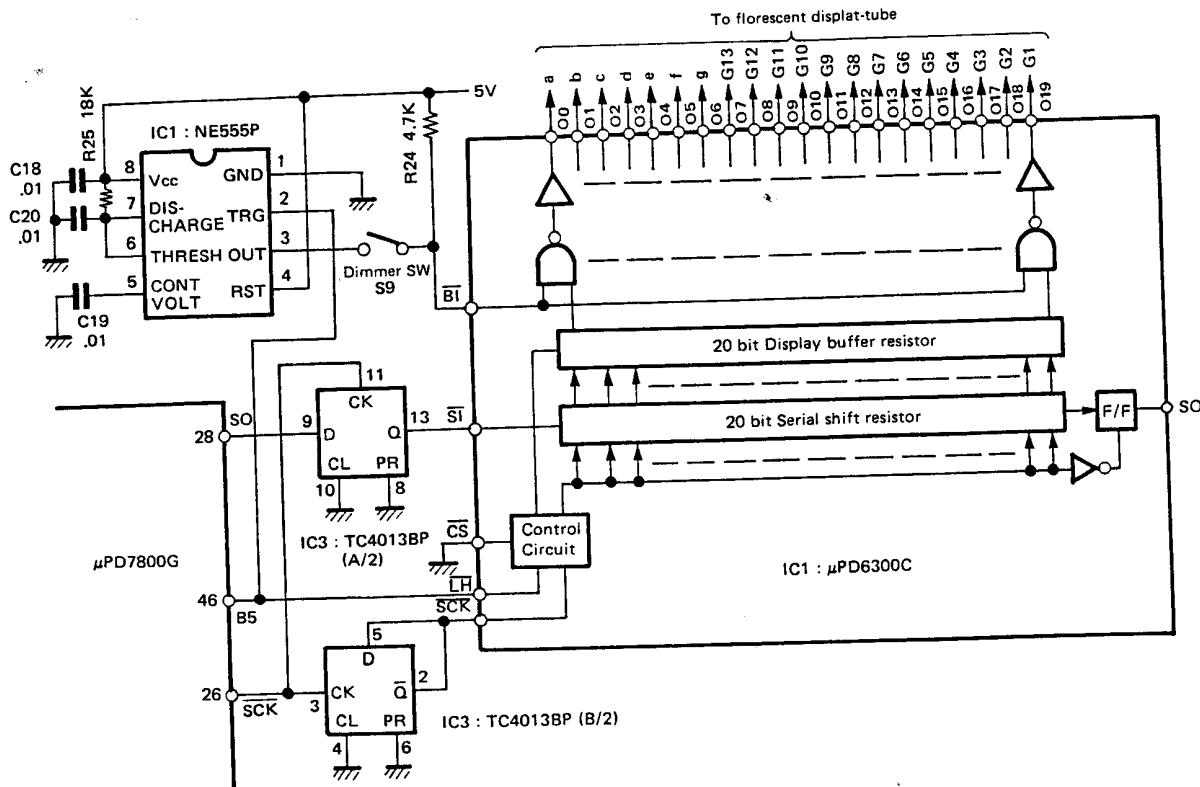

Fig. 19 Digital display circuit

# CIRCUIT DESCRIPTION

## ● A/D Converter Analog Input

The R-5000 uses four A/D converters to generate digital signals for IF shifting, carrier point correction, scan speed and scan resume time, which are read by the microprocessor. The A/D converter in the Display unit is linked by the channel select signal and control signal for data input from the Control unit. The microprocessor sends the

channel select signal first. A positive-going pulse from port B0 of IC2 : M5M82C55AP-5 resets the MB4052 A/D converter. After nine clock pulses from port C0 of the  $\mu$ PD7800G have been sent, the digital output of the A/D converter is sent to port C7 of microprocessor synchronized with the clock. **Fig. 20** and **21** show the circuits associated with the A/D converter and the timing diagram.

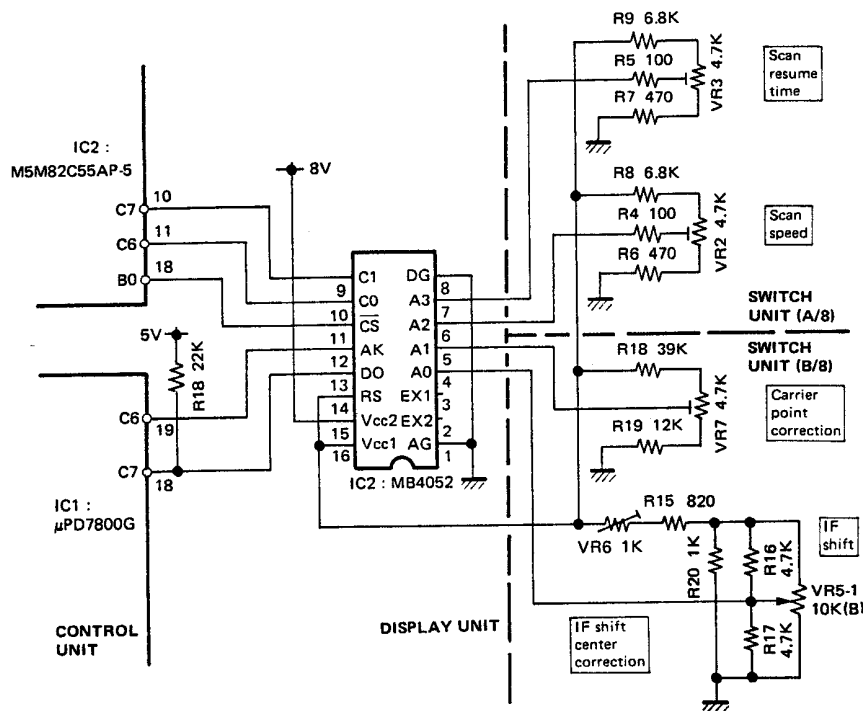

Fig. 20 A/D converter peripheral circuit

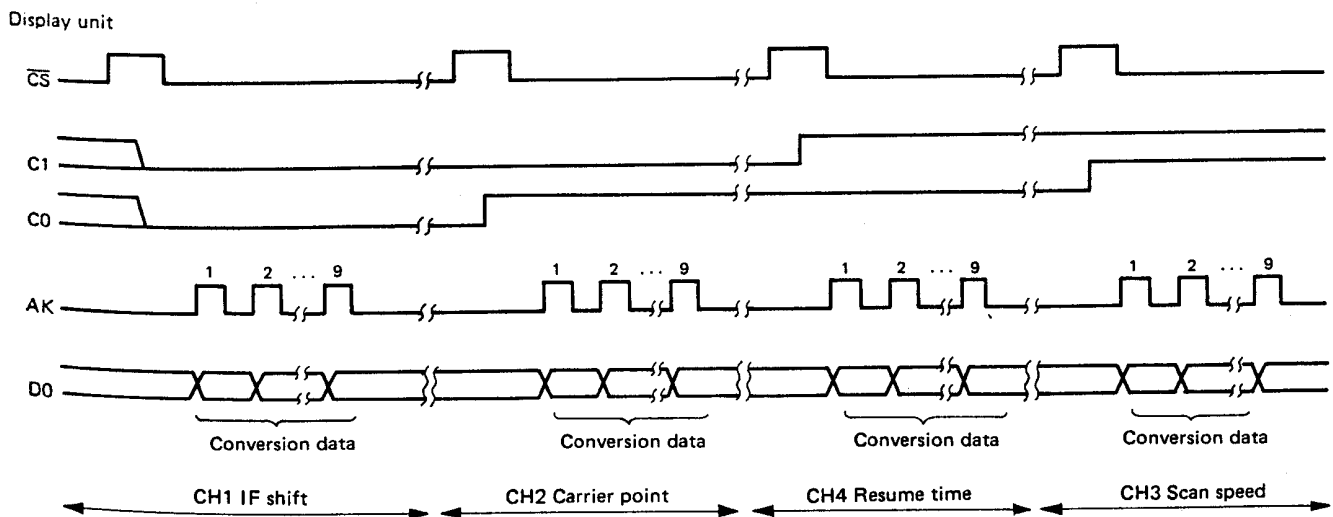

Fig. 21 A/D converter data timing chart

# R-5000

## CIRCUIT DESCRIPTION

### ● PLL Data

The R-5000 has five phase-locked loops, four of which are standard and one of which is part of the optional VHF converter. Two types of loops are used: an MB87006 for serial data input and an MN61471C for 4-bit parallel data input. Data is generated from the VFO and the received frequency in memory by calculation, and sent to the PLL chips.

The MB87006 chip for PLL2, PLL3, and PLL5 uses serial input data. It requires two inputs: the reference frequency division ratio and variable divider data. Since the comparison frequency does not have to be changed, it is sent only once, when power is switched ON.

The MN6147C chip used for PLL1 and PLL4 is a 4-bit parallel device. Reference division data and variable division data are set by sending data eight times with clock pulses. The chip has an internal latch so only the bits that change in G1 to G7 are sent; data is latched on the G8 latch pulse, which shortens the data transfer time. (See Fig. 22 and 23.)

Ports B0 to B6 of IC2 : M5M82C55AP-5 and SCK and S0 of IC1 :  $\mu$ PD7800G are data output ports. From the microprocessor's built-in serial ports CSK and S0, the MB87006 phase-locked loop receives microprocessor data multiplied with display data. Latch enable pulses are sent from microprocessor ports B4 (LE2 for the UHF PLL) and B6 (LE1 for the HF PLL), and from port B5 of IC2 (CL2 for PLL2). At the MN6147C chip, ports B0 to B3 of IC2 are the four-bit data; the clock pulses come from port B4 of IC2 (CL1 for PLL1) and port B6 of IC2 (CL4 for PLL4)

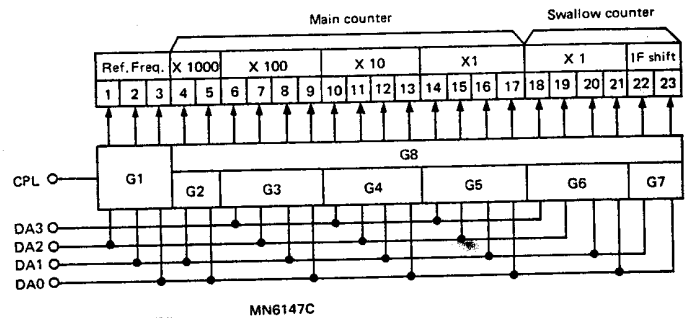

Fig. 22 Relationship between data input terminal and programmable counter

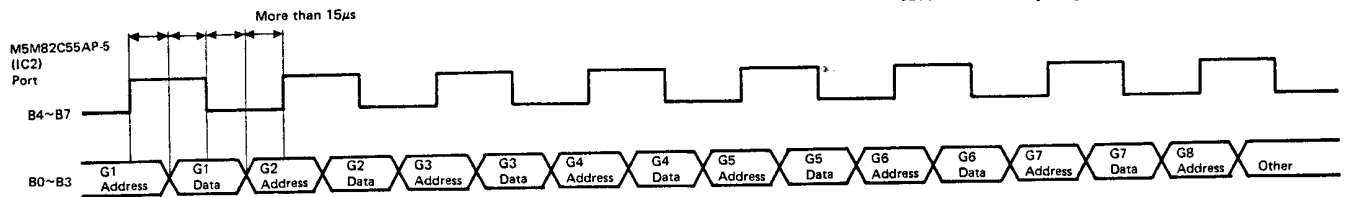

Fig. 23 MN6147C PLL data

### ● Band Information

The 4-bit band information from the Control unit is sent to the RF unit and optional converter unit, where it selects the RF bandpass filters and the VCO of the last phase-locked loop. Hexadecimal 0 to 9 designate the HF

band, hexadecimal C to F the VHF band. Table 4 indicates the bandpass filters and voltage-controlled oscillators selected by the band information.

Hexa-decimal	BAND data				B.P.F.	VCO	Active pin	
	RB3	RB2	RB1	RB0			RF unit IC1 Goes "L" when selected.	pin
0	0	0	0	0	J (21.5~30MHz)	VCO 4		
1	0	0	0	1	I (14.5~21.5MHz)	VCO 3	pin 2	
2	0	0	1	0	H (10.5~14.5MHz)	VCO 2	pin 3	
3	0	0	1	1	G (7.5~10.5MHz)		pin 4	
4	0	1	0	0	F (5.5~7.5MHz)	VCO 1	pin 5	
5	0	1	0	1	E (3.5~5.5MHz)		pin 6	
6	0	1	1	0	D (2.5~3.5MHz)		pin 7	
7	0	1	1	1	A (0~0.5MHz)		pin 9	
8	1	0	0	0	B (0.5~1.6MHz)		pin 10	
9	1	0	0	1	C (1.6~2.5MHz)	pin 11		
A	1	0	1	0	Not used			
B	1	0	1	1				
C	1	1	0	0	VA (108~123MHz)	VCO LL	C-20 IC103 Goes "L" when selected.	pin 12
D	1	1	0	1	VB (123~138MHz)	VCO L		pin 11
E	1	1	1	0	VC (138~155MHz)	VCO H		pin 10
F	1	1	1	1				

# CIRCUIT DESCRIPTION

● **Key Scan**

Ports C and A of IC53 : M5M82C55AP-5 form the key scan matrix. The key scan signal is output on a negative pulse from port C. The corresponding column of port A

is selected, and the state of the switch is read. If a switch at is on, the corresponding bit of port A goes low, indicating which switch has been pressed.

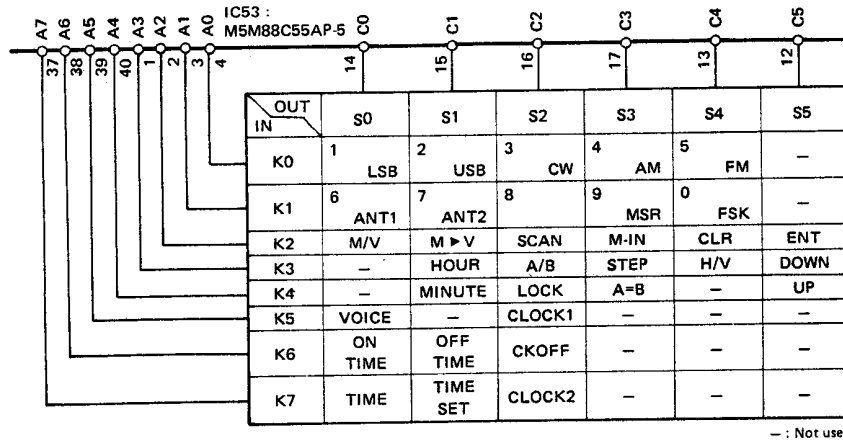

Fig. 24 Keyscan matrix

● **Extended Functions**

Diodes D65 to D72 provide extended functions with definitions as listed in the table below. These extended functions are read only once, when power is turned ON.

	Shipped	When diode cut :
D65 Display	10Hz	100Hz
D66 Mode buzzer	Morus	Single tone
D67 FM step	STEP ON : 2.5kHz	STEP ON : 500Hz
D68 BUSY stop	FM, AM only	All mode
D69 Memory search	No exist	The BAND UP/DOWN switch is the search button, which is valid in the MSR and MCH modes. In the MCH mode the channels stored in memory are searched. In the MSR mode, the channels not stored in memory are searched.
D70 D71		Not used
D72 Memory protection	OFF	Memory Protection : ON Channel information that has been written into memory cannot be altered or erased. Channel information is erased, however, if back-up power is lost.

Table 5 Extended functions

● **Static input**

IC1 : μPD7800G

Terminal	Signal		Function	
Name	No.	Symbol	Name	
C0	25	EUD	Encoder UP/DOWN signal	H : UP, L : DOWN
C1	24	PWR	Power switch signal	H : OFF, L : ON
C2	23	ULK	PLL low-digit unlock	H : LOCK, L : UNLOCK
C7	18	D0	A/D converter data	

IC53 : M5M82C55AP-5

Terminal	Signal		Function	
Name	No.	Symbol	Name	
B0	18	MT2	External mute signal	H : NONE, L : MUTE
B1	19	BSY	BUSY signal (counter stop)	H : NONE, L : BUSY
B3	21	HUL	PLL IF high-digit unlock	H : UNLOCK, L : LOCK
B4	22	VUL	PLL VHF high-digit unlock	H : UNLOCK, L : LOCK
B6	24	C0	BUSY stop T0/C0	H : C0, L : T0
B7	25	BY	VS-1 BUSY signal	H : VS-1 sound output, L : NONE

Table 6 Static input signal list

● **DC-DC Converter**

The DC-DC converter drives the fluorescent indicator tubes in the Display unit. The converter changes 10V input into -21V and 3.4V AC outputs for the filaments. The negative voltage (-5V) required by the IF unit is delivered from the -21V. The converter consists of two 2SC1959(Y) self-oscillators with frequency of about 17kHz.

## CIRCUIT DESCRIPTION

### External Control Baud Rate Oscillation Circuit

When serial data is exchanged between the R-5000 and a personal computer, usual transfer rate is 300, 1200, or 4800 baud. The desired baud rate is produced by a

binary counter that divides the frequency of 2.4576MHz of ceramic oscillator (X50) in the Control unit.

The circuit can be set as high as 76.800 baud, best in practice the upper limit is 4800 or 9600. baud.

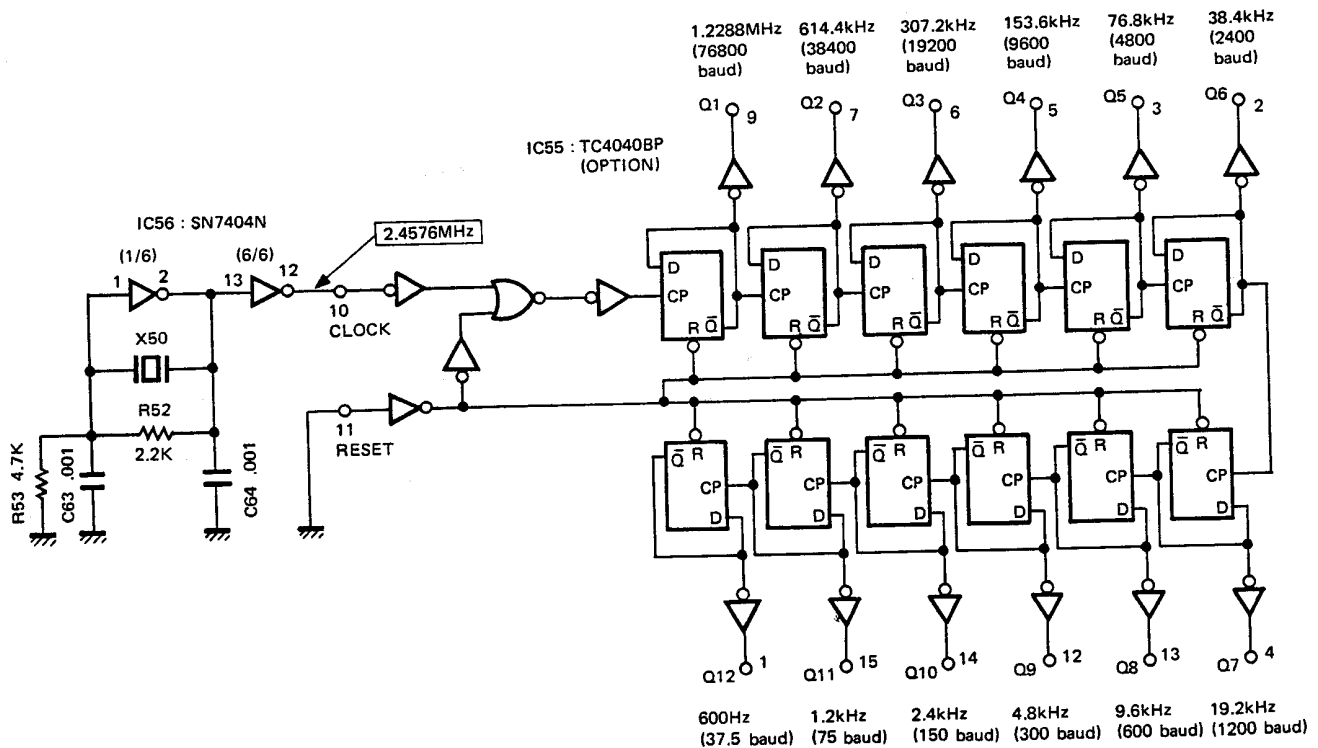

Fig. 25 Serial interface baud rate oscillation circuit

### Output Ports

1. Mode signals M1 to M6 ( $\mu$ PD7800G ports A0 to A5)

The signals designating the LSB, USB, CW, AM, FM, and FSK modes are sent from the microprocessor. When the mode lamp on the keyboard assembly lights, the corresponding mode signal is sent to the IF unit. These are open-collector output.

2. Timer Relay Signal TRL ( $\mu$ PD7800G port A6)

To support the timer and clock display functions of the R-5000, its microprocessor begins running as soon as the power cord is plugged in, and keeps running as soon as long as power is supplied. The timer relay signal turns the power of the receiver section ON and OFF at the time set by the power switch and timer switch, using an open-collector signal.

3. VS1 Data PS0 to PS4, SR (IC2 : M5M82C55AP-5 A0 to A5)

Ports S0 to S4 output audio data. After the audio data is set, SR goes active (high) to send the audio.

4. Blanking BLK (IC2 : M5M82C55AP-5)

This signal removes the clicking that accompanies PLL switching. The signal is active (high) during the blanking period.

5. LED Output (IC2 : M5M82C55AP-5)

These open-collector terminals carry data that drives the LED indicators on the keyboard assembly. All four of the IC pins are active-high open-collector outputs. The indicators light when the output is active.

See **Table 7** for a table of inputs and outputs.

# CIRCUIT DESCRIPTION

IC1 :  $\mu$ PD7800G

Terminal name	I/O	Active	Symbol	Function
A0	O	H	M1	LSB mode
A1	O	H	M2	USB mode
A2	O	H	M3	CW mode
A3	O	H	M4	AM mode
A4	O	H	M5	FM mode
A5	O	H	M6	FSK mode
A6	O	H	TRL	Timer relay
A7	O	H	BZ	
B0	O	H	B0	Band data
B1	O	H	B1	
B2	O	H	B2	
B3	O	H	B3	
B4	O	H	LE2	VHF PLL enable
B5	O	H	LEF	Display enable
B6	O	H	LE1	HF PLL enable
B7	O	H	RES	
C0	I	-	EUD1	Encoder UP/DOWN
C1	I	-	PWR	Power switch
C2	I	-	ULK	PLL low-figure unlock
C3	O	H	X	Display data
C4	O	L	DP	
C6	O	H	AK	A/D acknowledge
C7	I	-	D0	A/D data

IC2 : M5M82C55AP-5

Terminal name	I/O	Active	Symbol	Function
A0	O	H	PS0	VS-1
A1	O	H	PS1	
A2	O	H	PS2	
A3	O	H	PS3	
A4	O	H	PS4	
A5	O	H	SR	
A6	O	H	BLK	Blanking
B0	O	H	DA0	Combinedly used for ADCS and MN6147C data
B1	O	H	DA1	
B2	O	H	DA2	
B3	O	H	DA3	
B4	O	H	CL1	10Hz PLL
B5	O	H	CL2	50kHz PLL
B6	O	H	CL4	BFO PLL
C0	O	H	AL1	ANT1 LED
C1	O	H	AL2	ANT2 LED
C2	O	H	MSC	MCR LED
C3	O	H	LKL	LOCK LED
C6	O	H	C0	A/D address
C7	O	H	C1	

IC53 : M5M82C55AP-5

Terminal name	I/O	Active	Symbol	Function
A0	I	L	K0	Key sense column
A1	I	L	K1	
A2	I	L	K2	
A3	I	L	K3	
A4	I	L	K4	
A5	I	L	K5	
A6	I	L	K6	
A7	I	L	K7	
B0	I	H : Not MUTE, L : MUTE	MT2	External mute
B1	I	H : Not BUSY L : BUSY	BSY	BUSY signal
B3	I	H : UNLOCK L : LOCK	HUL	HF unlock
B4	I	H : UNLOCK L : LOCK	VUL	VHF unlock
B6	I	H : CO, L : T0	CO	Carrier operate
B7	I	H : Talking L : Not BSY	BY	VS-1 BSY signal
C0	O	L	S0	Key sense
C1	O	L	S1	
C2	O	L	S2	
C3	O	L	S3	
C4	O	L	S4	
C5	O	L	S5	

Table 7 I/O signal pin function

## SEMICONDUCTOR DATA

### Keyboard Ass'y (W03-2005-05)

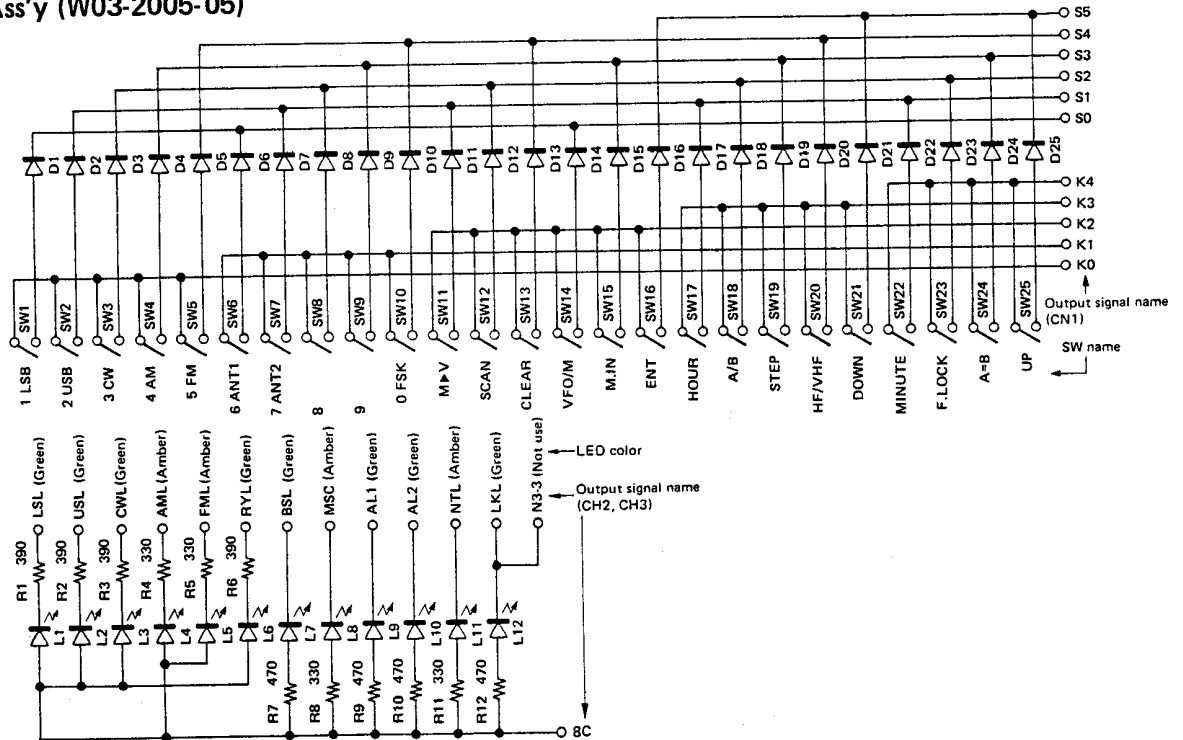

### MN6147C (PLL unit IC2, IC14)

#### Terminal connection diagram

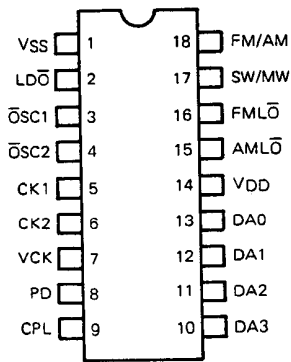

#### Block diagram

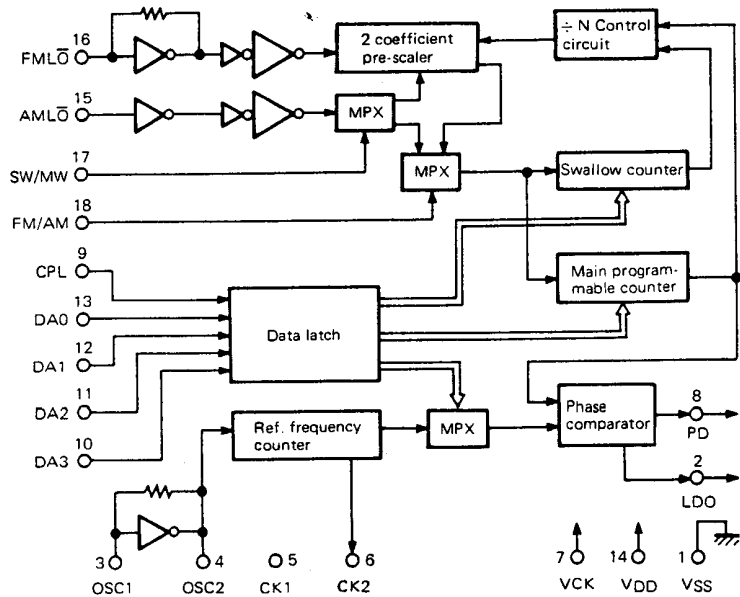

#### Terminal functions

Terminal No.	Symbol	Terminal function	Terminal No.	Symbol	Terminal function
1	VSS	GND	10	DA3	Data and address input (MSB)
2	LDO(QO)	Lock detector output (OSC circuit output)	11	DA2	Data and address input
3	OSC1	4.5MHz X'tal OSC	12	DA1	
4	OSC2		13	DA0	Data and address input (LSB)
5	CK1	Clock output 1 (562.5kHz)*	14	VDD	Main power supply (+ 5V)
6	CK2	Clock output 2 (250Hz)	15	AMLO	AM band OSC signal input
7	VCK	Clock divider circuit, battery back-up (+ 5V)	16	FML0	FM band OSC signal input
8	PD	Latch detector output (three states)	17	SW/MW	SW/MW select
9	CPL	Latch clock	18	FM/AM	FM/AM select

# SEMICONDUCTOR DATA

## MB87006 (PLL unit IC8, IC12)

### Terminal connection diagram

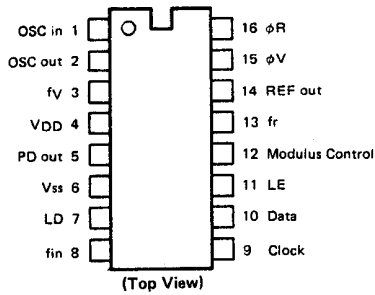

Terminal No.	I/O	Terminal name	Terminal No.	I/O	Terminal name
1	I	OSC in	9	I	Clock
2	O	OSC out	10	I	Data
3	O	fv	11	I	LE
4	-	VDD	12	O	Modulus Control
5	O	PD out	13	O	fr
6	-	VSS	14	O	REF out
7	O	LD	15	O	$\phi V$
8	I	fin	16	O	$\phi R$

### Block diagram

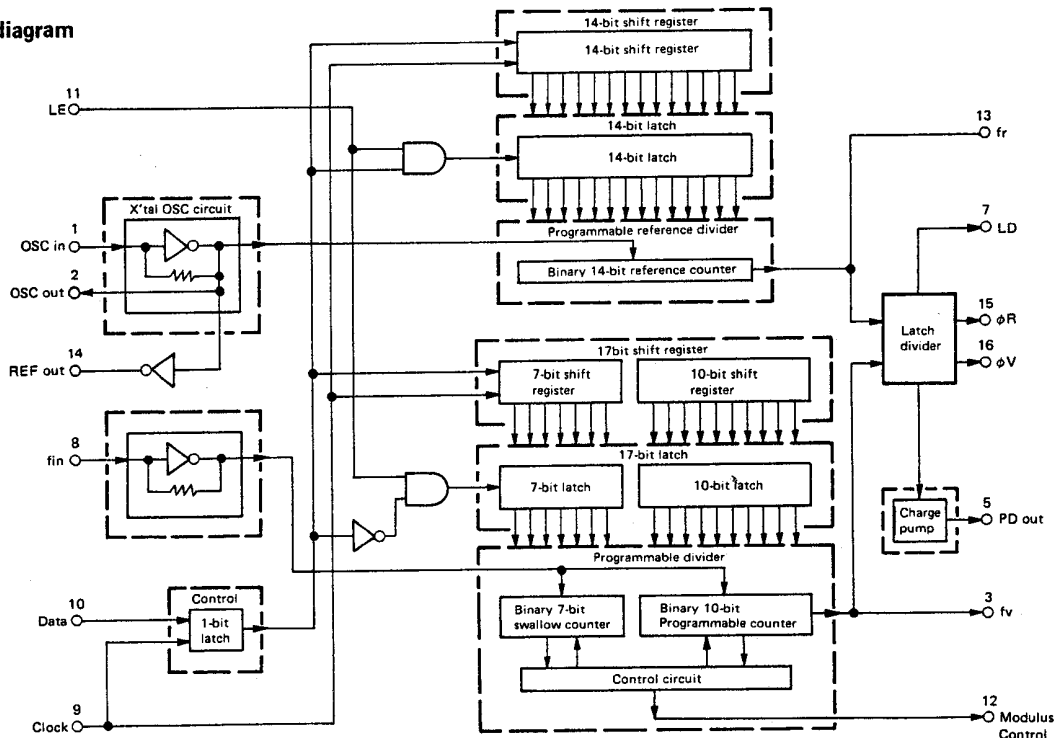

## $\mu$ PB551C (PLL unit IC9)

### Terminal connection diagram

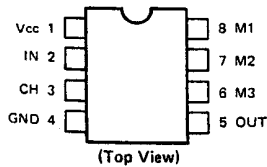

### Block diagram

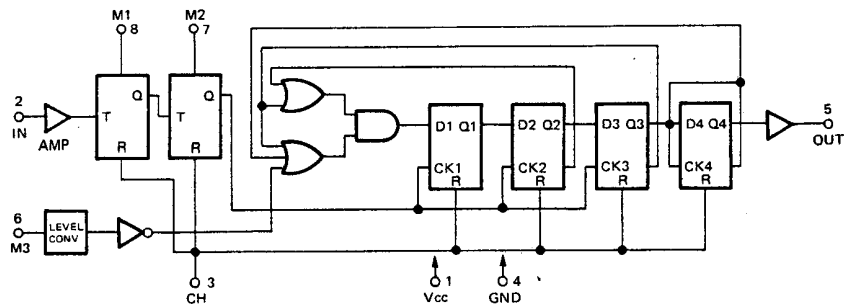

### Divide ratio

Divider ratio	M1	M2	M3
40	GND	GND	L
44	GND	GND	H
20	GND	Vcc	L
22	GND	Vcc	H
10	Vcc	Vcc	L
11	Vcc	Vcc	H

### Terminal function

Terminal No.	Symbol	Function
1	Vcc	Power supply terminal (+ 5V)
2	IN	AC signal input
3	CH	Check, Normally GND
4	GND	GND
5	OUT	Output terminal
6	M3	Frequency division ratio
7	M2	Frequency division ratio

# R-5000

## SEMICONDUCTOR DATA

### μPD7800G (Control unit IC1)

- Terminal connection diagram
- Block diagram

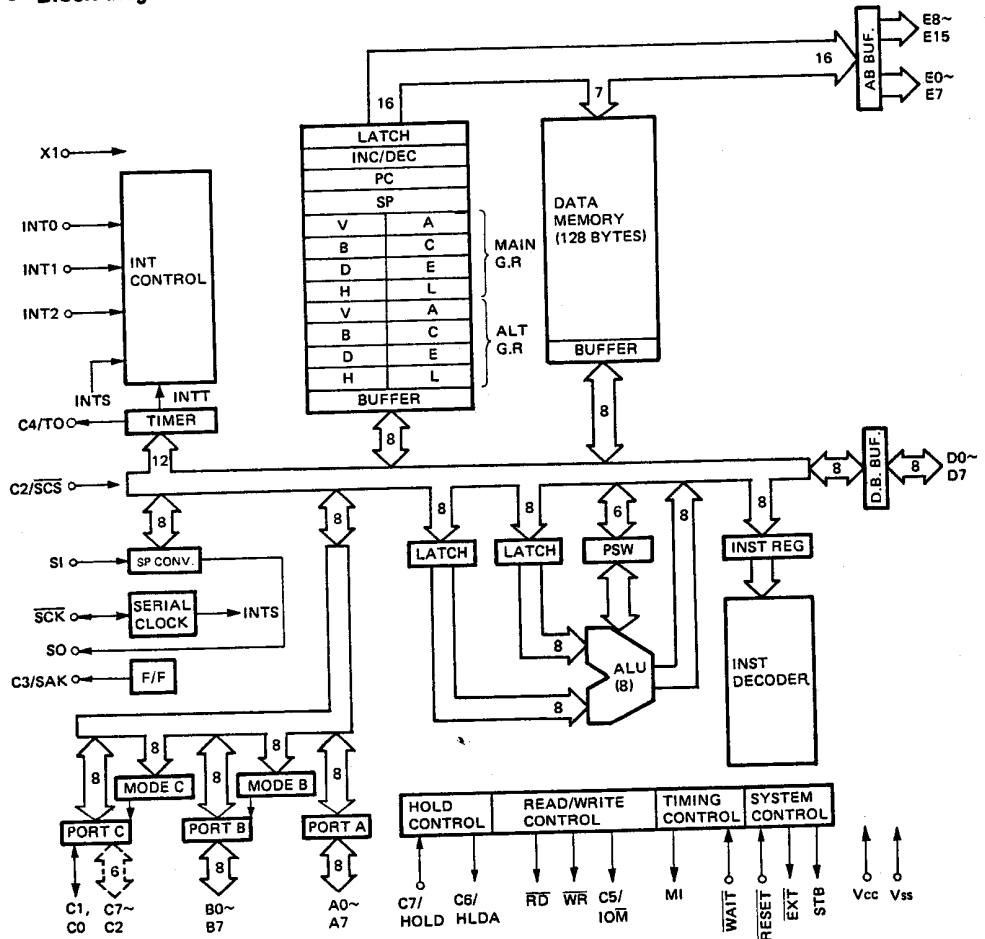
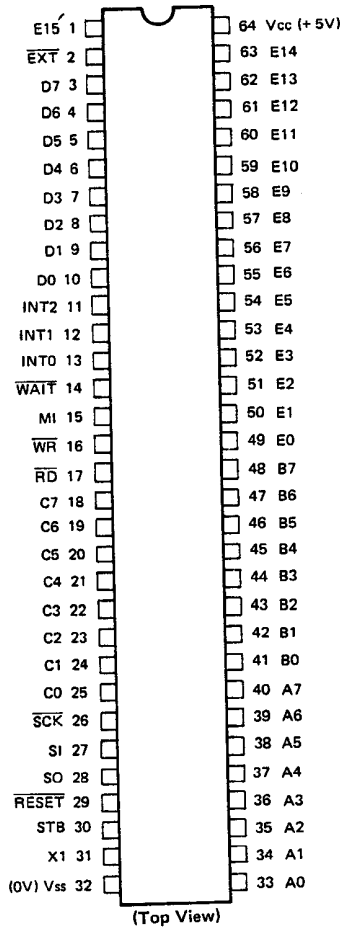

### TC4069UBP (Control unit IC4)

- Block diagram

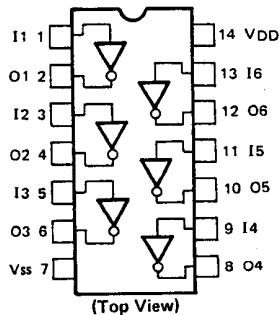

### TC4011BP (Control unit IC5, IC7)

- Logic circuit

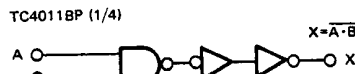

- Block diagram

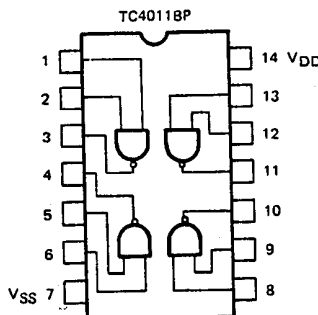

### TC4030BP (Control unit IC6)

- Block diagram

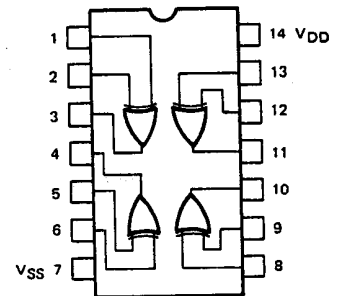

- Truth table

INPUT		OUTPUT
A	B	X
L	L	L
L	H	H
H	L	H

# SEMICONDUCTOR DATA

## M5M82C55AP-5 (Control unit IC2, IC53)

### ● Block diagram

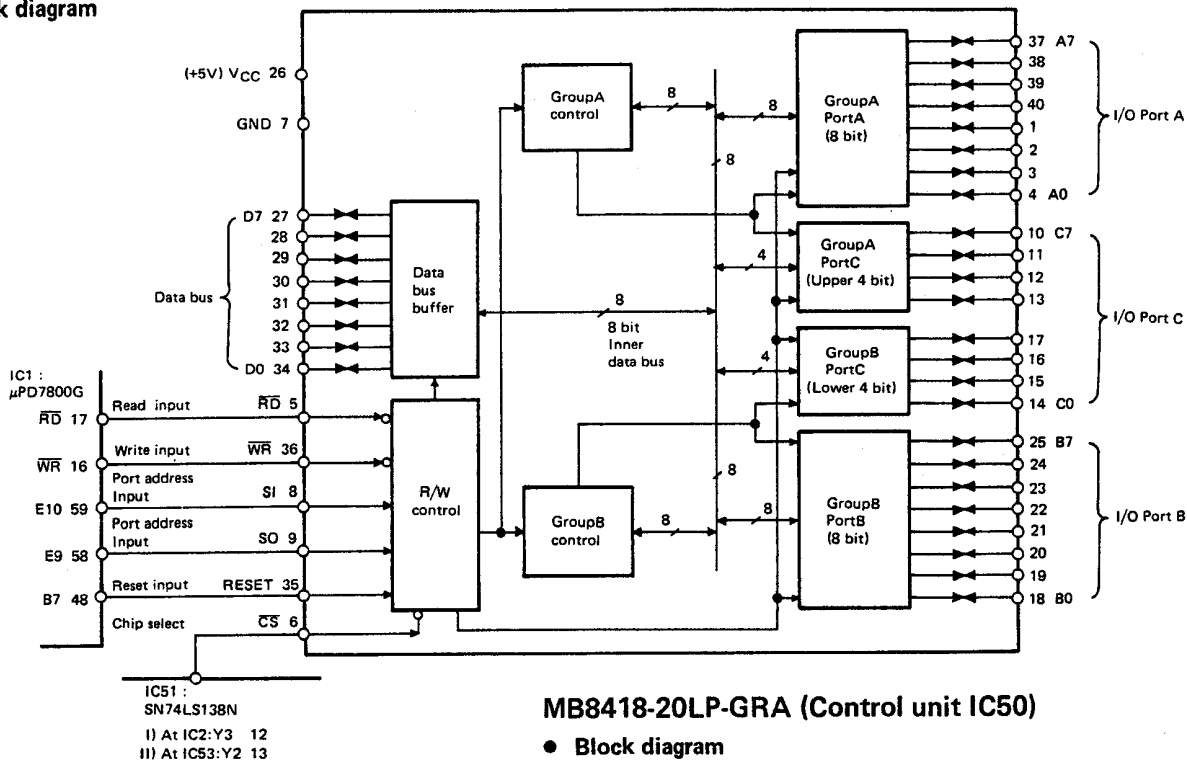

### ● Terminal connection diagram

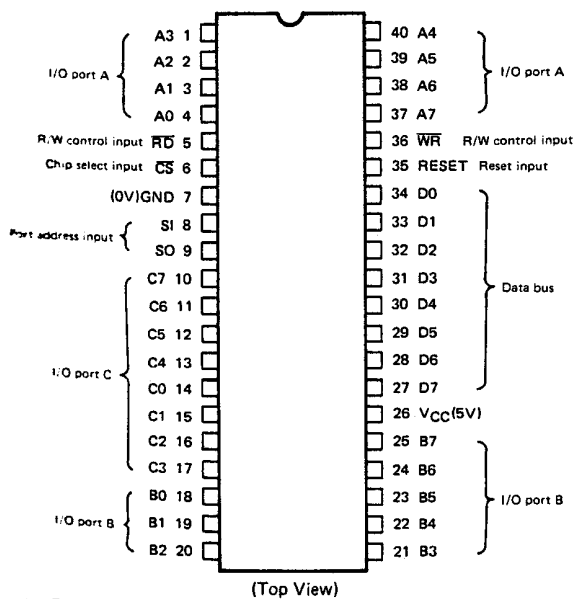

### ● Basic function

SI	SO	CS	RD	WR	Function
L	L	L	L	H	Data bus ← Port A
L	H	L	L	H	Data bus ← Port B
H	L	L	L	H	Data bus ← Port C
L	L	L	H	L	Port A ← Data bus
L	H	L	H	L	Port B ← Data bus
H	L	L	H	L	Port C ← Data bus
H	H	L	H	L	Control register ← Data bus
					Data bus is in the high-impedance state.

## MB8418-20LP-GRA (Control unit IC50)

### ● Block diagram

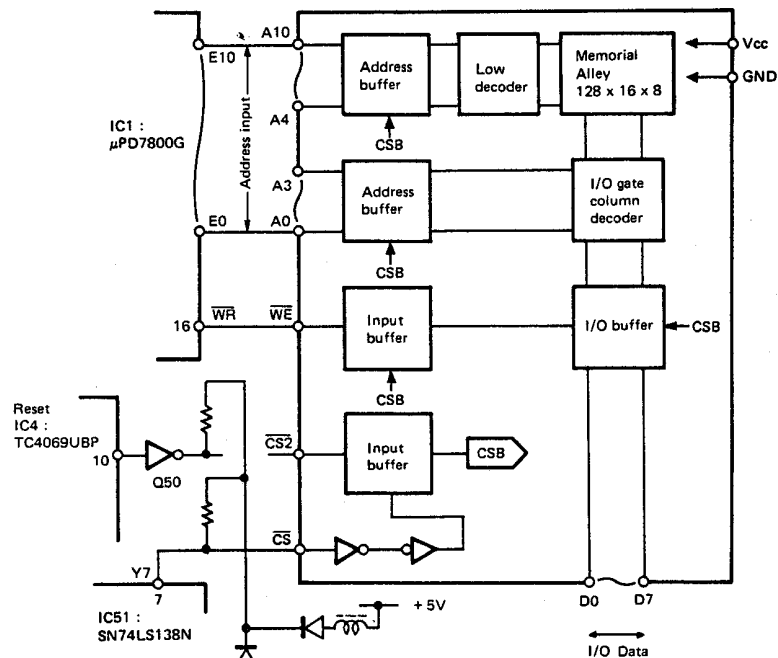

### ● Terminal function

Terminal name	Function
A0~A10	Address input
D0~D7	Data input/output
CS	Chip select 1
CS2	Chip select 2
WE	Write enable
Vcc	Power supply (+5V)

## SEMICONDUCTOR DATA

### SN74LS138N (Control unit IC51)

● Logic circuit

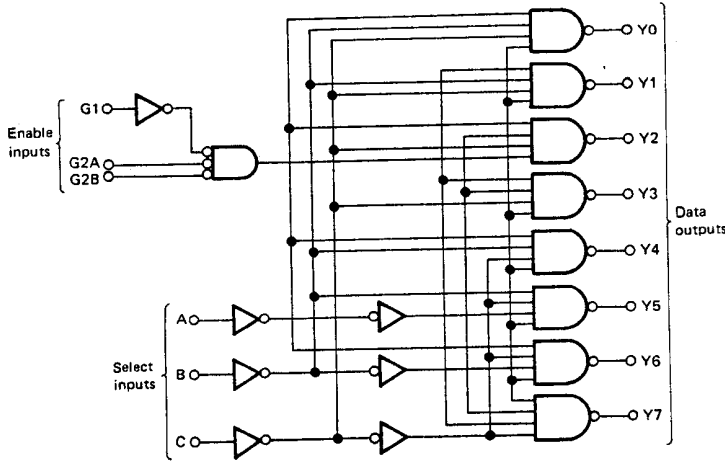

### MBM27128-25JB1 (Control unit IC52)

● Block diagram

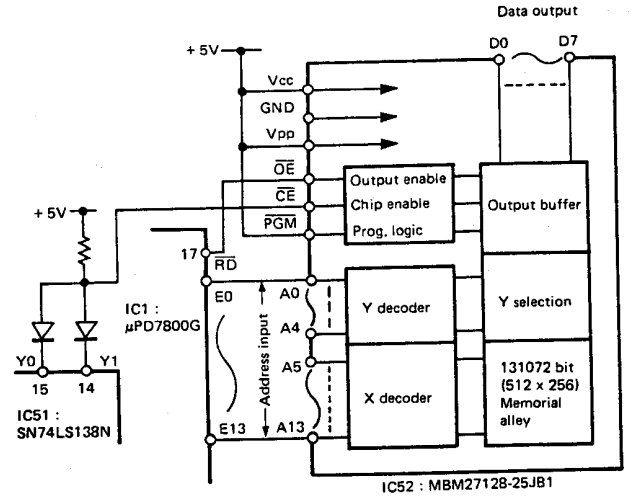

● Block diagram

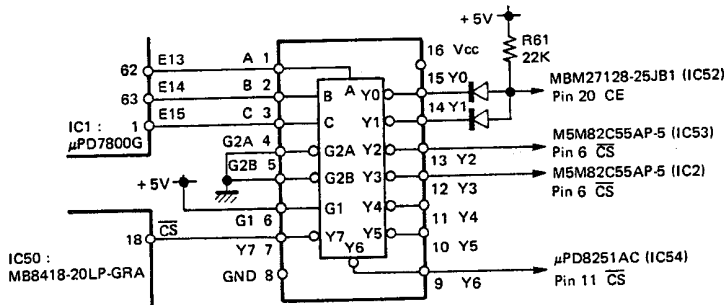

● Terminal function

Terminal name	Function
A0~A13	Address input
D0~D7	Data output
$\overline{CE}$	Chip enable input
$\overline{OE}$	Output enable input
PGM	Program input
Vcc	Power supply
Vpp	Program power supply
GND	Ground

● Truth table

INPUT					OUTPUT							
Enable		Select			Y0	Y1	Y2	Y3	Y4	Y5	Y6	Y7
G1	G2	C	B	A								
X	H	X	X	X	H	H	H	H	H	H	H	H
L	X	X	X	X	H	H	H	H	H	H	H	H
H	L	L	L	L	L	H	H	H	H	H	H	H
H	L	L	L	H	H	L	H	H	H	H	H	H
H	L	L	H	L	H	H	L	H	H	H	H	H
H	L	L	H	H	H	H	H	L	H	H	H	H
H	L	H	L	L	H	H	H	H	L	H	H	H
H	L	H	L	H	H	H	H	H	H	L	H	H
H	L	H	H	L	H	H	H	H	H	H	L	H
H	L	H	H	H	H	H	H	H	H	H	H	L

Note 1 : G2 = G2A + G2B

Note 2 : H : High level  
L : Low level  
X : Either "H" or "L"

## SEMICONDUCTOR DATA

### μPD8251AFC (Control unit IC54) : Optional

● Block diagram

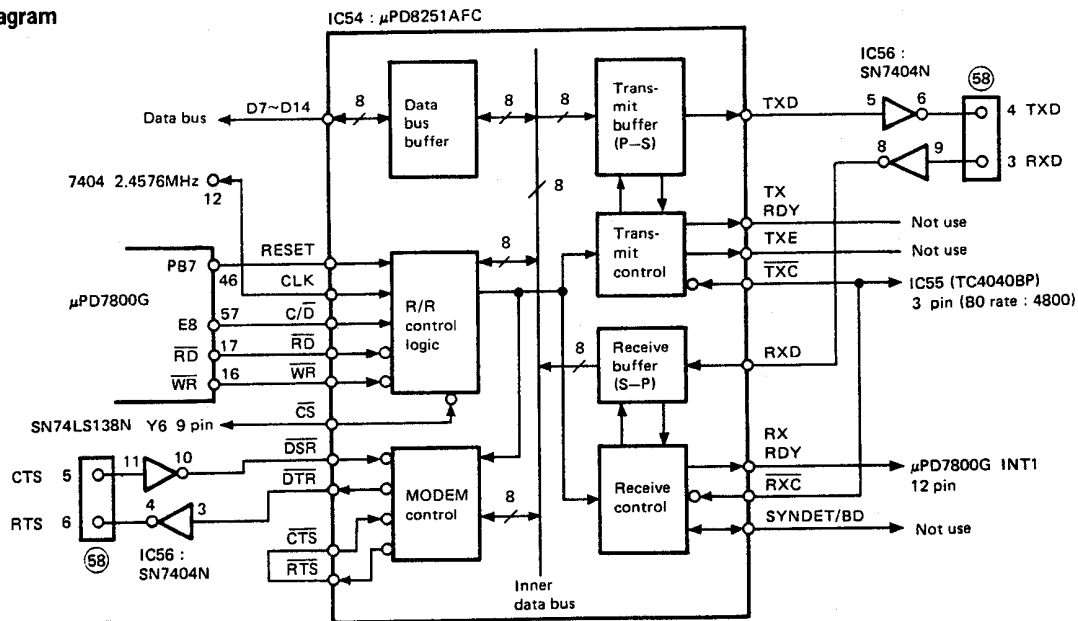

### TC4040BP (Control unit IC55) : Optional

● Block diagram

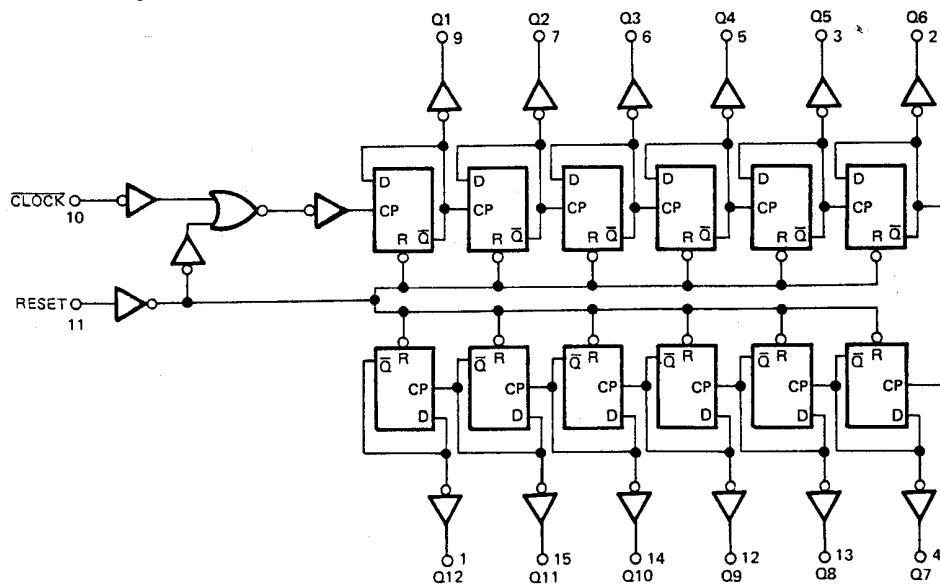

### SN7404N (Control unit IC56)

● Block diagram

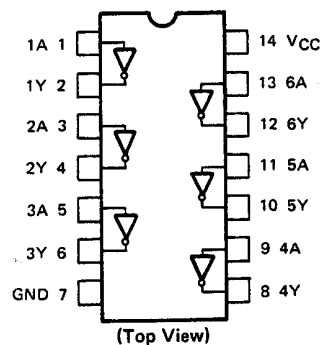

# R-5000

## SEMICONDUCTOR DATA

### MSM6242RS (Control unit IC57)

● Block diagram

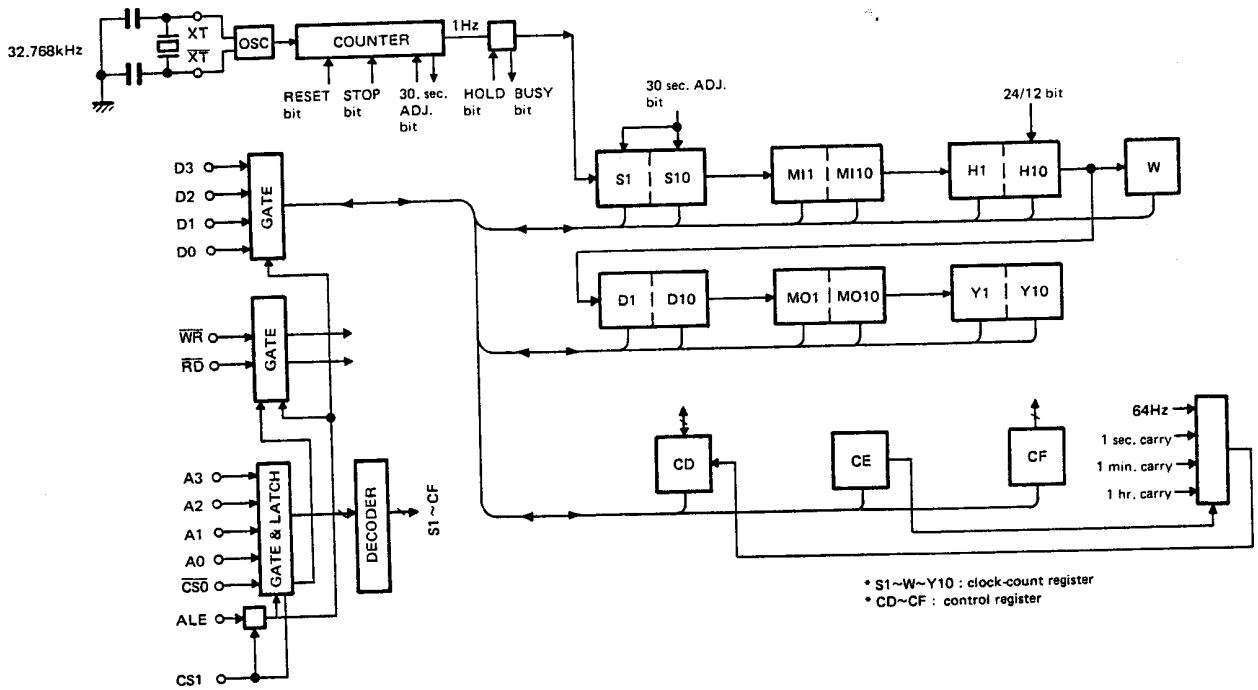

● Terminal connection diagram

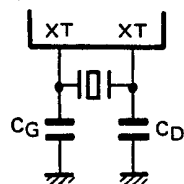
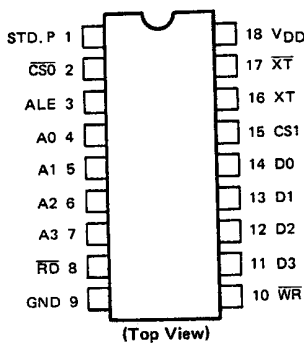

Crystal : NIPPA MX38T (32.768kHz)  
 Load capacitance  $C_L = 13\text{pF}$   
 Equivalent serial resistance  $30\text{k}\Omega$  (max.)  
 Frequency characteristic secondary temperature coefficient :  $-4.2 \times 10^{-8}/^\circ\text{C}$   
 $C_G, C_D : 22\text{pF}$  (with a temperature characteristic)

### X'tal filter (L77-1256-05) (Control unit X51)

● Oscillation frequency dependency on supply voltage ( $T_a = 25^\circ\text{C}$ )

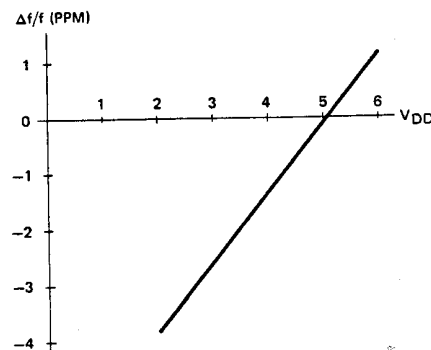

● Oscillation frequency dependency on temperature

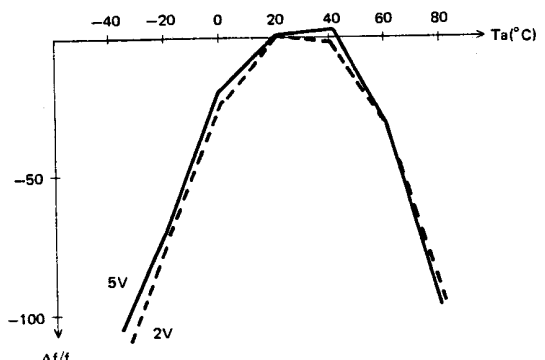

# SEMICONDUCTOR DATA

## μPD6300C (Display unit IC1)

### ● Terminal function

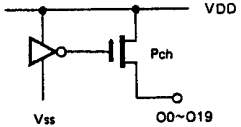
Terminal No.	Symbol	Terminal name	I/O	Function
1~7	O13~O19	FIP segment driver	O	High dielectric-strength (40V) output in the Pch open. Corresponds to the output of Q13~Q19.
8	SO	Serial data output pin	O	Output serial data the trailing edge of SCK, when the n-number of μPD6300Cs are connected in series, this can be connected to the SI of the following stage.
9	$\bar{B}i$	Blanking pin	I	This input can turn off all indicator or displays, and can dim them by applying a random duty pulse from outside. Active low.
10	$\bar{L}H$	Latch pin	I	Transmits the connects of the serial shift register to the buffer register at low level, to latch the connects at the rising time. Active rising (leading) edge.
11	SI	Serial data input pin	I	This is the data input pin. Inputs data to the shift register at the rising edge of SCK.
12	SCK	Serial clock input pin	I	Reads out the SI data to the shift register at the rising edge of SCK. Outputs data from SO at the trailing edge of SCK.
13	$\bar{C}S$	Chip select pin	I	When CS is high, this inhibits SCK and $\bar{L}H$ , and when CS is low, activates SCK and $\bar{L}H$ .
14	Vss	GND	-	Connect to the GND terminal of the system.
15~27	O0~O12	FIP segment driver	O	Pch open-drain system, high dielectric-strength output. Corresponds to the output of O0~O12. 
28	VDD	Power supply pin	-	5V ± 10%

### ● Terminal connection diagram

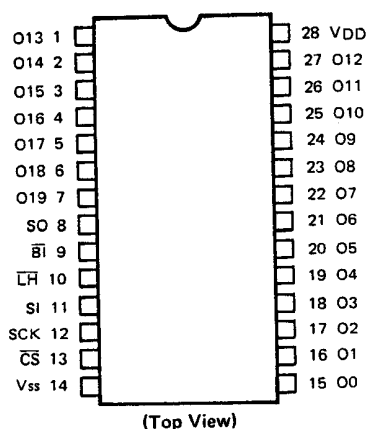

### ● Logic circuit

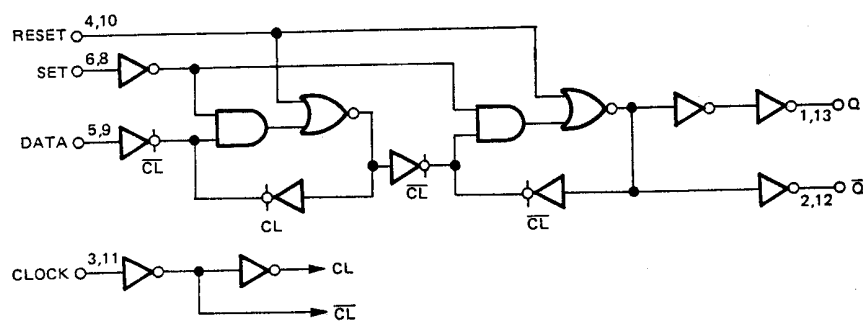

### ● Block diagram

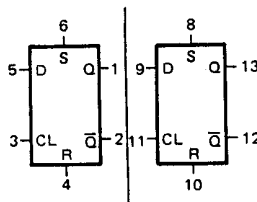

## SEMICONDUCTOR DATA

### MB4052 (Display unit IC2)

#### Terminal connection diagram

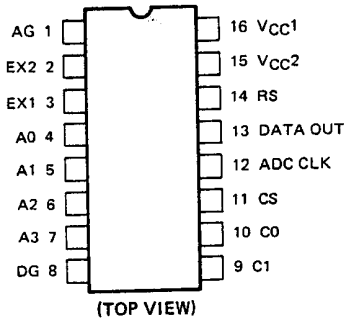

#### Block diagram

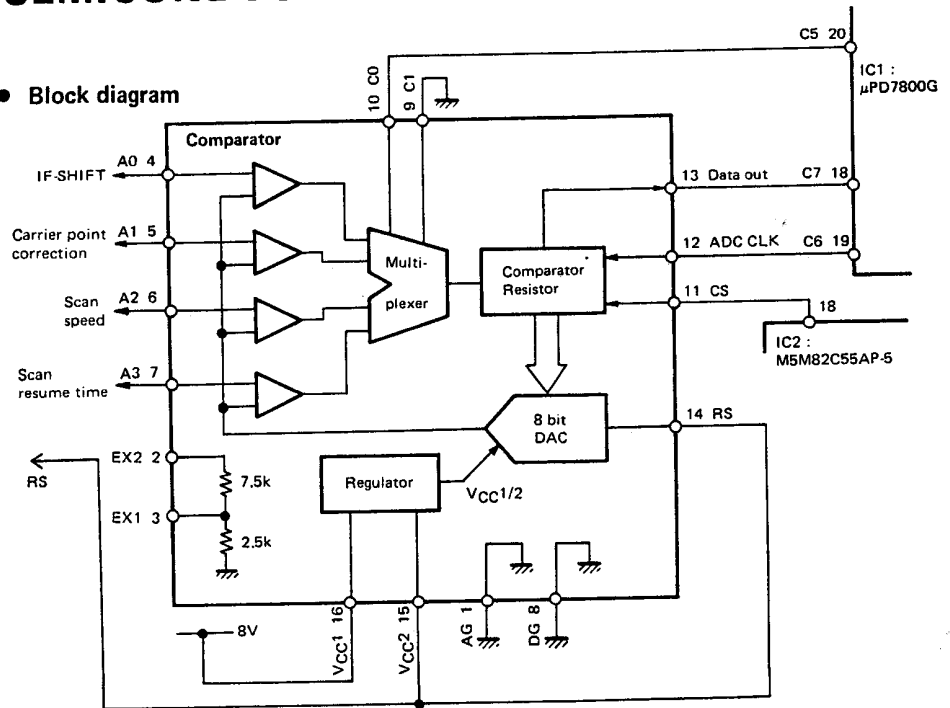

#### I/O signal pin function

Pin No.	Pin name	Symbol	Function
1	Analog ground	AG	Ground terminal
2	Range expander input	EX2	Analog input pin for expanding the range.
3	Range expander output	EX1	Analog output pin for expanding the range. Connect to any pin from A0 to A3. By using EX1, EX2, the range is expanded to the X 4 range.
4~7	Analog entrance	A0~A3	4-ch analog input pin. Channel 1 is selected by channel select input C0 to C1.
8	Digital ground	DG	Ground terminal
9	Channel select input	C0	The input pin to designate the analog input channel for A/D converter. This signal is latched at the trailing edge of CS.
10		C1	
11	Chip select input	CS	This is the chip select input pin. When CS is inverted from "1" to "0", A/D converting starts and data output is enabled. After A/D converting is over or when an interrupt is required, set the CS back to "1".
12	A/D conversion clock	ADC CLK	This is the clock input pin for A/D conversion input to the comparator register sequentially. Conversion speed is determined by the clock speed. In the case of 8-bit, approx. 10 clocks will be needed. However, it is not necessary that the clock period be fixed.
13	Data output	DATA OUT	This is the open collector to output the result of A/D conversion. The data is output in the order of the start bit, most significant bit, 2nd significant bit, . . . , least significant bit, and the stop bit, synchronized with ADCCLK.
14	Range select input	RS	This is the input pin for selecting the voltage range of analog input. The VFS = VCC1/8 range is selected at "0", and the range of FVS = VCC1/2 is selected at "1". During conversion, hold this pin to "0" or "1".
15	Power supply pin 2 Power supply pin 1	VCC2 VCC1	When driving with 3.5V to 6.0V of power, connect VCC1 and VCC2 to each other, and apply the power voltage to them.
16			When driving 8 to 18V of power, apply the power voltage to VCC2. At this time, the 5V stabilized voltage is output to VCC1, and approx. 10mA current can be supplied externally to the IC. When either 3.5~6.0V or 8~18V power is used, VCC1 is the reference voltage for A/D conversion.

#### Channel select

C1	C0	Selected Ch.
0	0	A0
0	1	A1
1	0	A2
1	1	A3

#### Range select

RS	Conversion voltage range
0	$0 \sim \frac{V_{CC1}}{8}$
1	$0 \sim \frac{V_{CC1}}{2}$

#### Wiring example when expanding the range

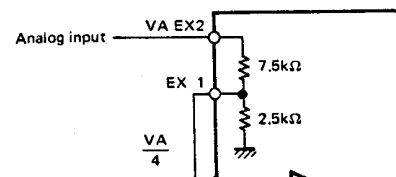

## DESCRIPTION OF COMPONENTS

## SWITCH UNIT (X41-3000-00)

Component	Function	Operation/condition
IC1	DIM brightness setting	
D1~8	Reverse current blocking	

## AVR UNIT (X43-3000-00)

Component	Function	Operation/condition
IC1	10V AVR	Input voltage : 13.6V, Output voltage : 9.8V.
IC2	5V AVR	Input voltage : 9.5V, Output voltage : 5.0V.
Q1	Mute switching	"H" when muting, "L" otherwise.
Q2	8V AVR	Input voltage : 9.8V, Output voltage : 8.0V
D1~6,9	Reverse current blocking	
D7	8V AVR reference voltage	
D8	Battery charging circuit reference voltage	

## RF UNIT (X44-3010-00)

Component	Function	Operation/condition
IC1	Band-pass data decoder	① 21.5~30MHz ⑦ 2.5~3.5MHz ② 14.5~21.5MHz ⑧ GND ③ 10.5~14.5MHz ⑨ 1.6~2.5MHz ④ 7.5~10.5MHz ⑩ 0.5~1.6MHz ⑤ 5.5~ 7.5MHz ⑪ 0~0.5MHz ⑥ 3.5~ 5.5MHz
Q1,2	RF amplifier	Cascode amplifier.
Q3,4	Mixer amplifier	Balanced mixer.
Q5,6	Post amplifier	Push-pull amplifier.
Q7	+ 9V line switching	ON during HF reception and OFF during VHF reception.
Q8~11	VCO	Q8 : 0~7.5MHz, Q9 : 7.5~14.5MHz Q10 : 14.5~21.5MHz, Q11 : 21.5~30MHz
Q12~14	Buffer amplifier	VCO buffer amplifier.
Q15	Buffer amplifier	PLL VCO buffer amplifier.
Q16	VFO amplifier	VCO buffer amplifier.
D1~3	Relay spike voltage killer	
D4,5	ATT relay reverse current blocking	Ensures proper relay operation with VC-20 attached.
D6,7	Receiver protection	Turned ON by excess antenna input power.
D8~27	BPF switching	D 8, 9 : 1.6~2.5MHz D18, 19 : 5.5~7.5MHz D10, 11 : 0.5~1.6MHz D20, 21 : 7.5~10.5MHz D12, 13 : 1.6~2.5MHz D22, 23 : 10.5~14.5MHz D14, 15 : 2.5~3.5MHz D24, 25 : 14.5~21.5MHz D16, 17 : 3.5~5.5MHz D26, 27 : 21.5~30MHz
D28	Voltage stabilizer	VCO circuit voltage stabilizer.
D29	VCO varicap diode	0~7.5MHz.
D30	VCO switching	0~7.5MHz.
D31	VCO varicap diode	7.5~14.5MHz.
D32	VCO switching	7.5~14.5MHz
D33	VCO varicap diode	14.5~21.5MHz.
D34	VCO switching	14.5~21.5MHz.
D35	VCO varicap diode	21.5~30MHz.
D36	VCO switching	21.5~30MHz.
D37	Q7 switching	HF/VHF switching.
D38,39	Switching	VCO, BPF switching.
D40	Voltage stabilizer	IC1 power supply.
D41	Reverse current blocking	Secures ANT1/ANT2 switching relay function.

# R-5000

## DESCRIPTION OF COMPONENTS

### IF UNIT (X48-3000-00)

Component	Function	Operation/condition
IC1 (1/2)	SSB detected signal pre-amplifier	Level matching and f-characteristic adjustment.
IC1 (2/2)	AM detected signal pre-amplifier	
IC2	AGC time constants switching	
IC3	AGC voltage amplifier and S meter driver	
IC4 (1/2)	SSB squelch switching	
IC4 (2/2)	D-AGC generator circuit	
IC5,6	FM IF	
IC7 (1/2)	FM detected signal pre-amplifier	Level matching, de-emphasis, and f-characteristic adjustment.
IC7 (2/2)	FM squelch switching	
IC8	Center detection window comparator	
IC9	Per-MODE detector output selector switching	
IC10	NOTCH, PEAK, and FLAT circuits	
IC11	NOTCH/PEAK/FLAT switching and squelch muting	
IC12	Active filter	
IC13	Audio power amplifier	
IC14	9V AVR	
IC15	SELECTIVITY control	
Q1	1st IF amplifier	Including D-AGC.
Q2	HET oscillator	49.2825MHz, 3rd overtone.
Q3	HET buffer amplifier	
Q4,5	2nd mixer	Balanced type.
Q6	UL blanking	Normally ON.
Q7	UL blanking	Normally OFF.
Q8	3rd local oscillator	8.375MHz.
Q9	3rd mixer	
Q10	NB gate	
Q11,12	NB noise amplifier	Including NB AGC.
Q13	NB noise buffer amplifier	
Q14	NB AGC driver	
Q15	NB blanking pulse generator	Including variable NB level feature.
Q16	NB blanking pulse generator	Including blanking delay time constant circuit.
Q17	NB gate driver	
Q18,20	2nd IF amplifier (MCF buffer)	Including temperature gain compensation feature.
Q19,21,22	2nd IF amplifier (MCF buffer)	Including AGC.
Q23	BFO amplifier	
Q24	2nd IF buffer amplifier	
Q25	NB blanking duty control	
Q26	AM detection	
Q27	AGC driver	
Q28	AGC time constant switch	
Q29	SSB squelch driver	
Q30	SSB squelch voltage follower	
Q31	Center detection switch	OFF when center is detected.
Q32,33	FM squelch noise amplifier	

## DESCRIPTION OF COMPONENTS

Component	Function	Operation/condition
Q34	Per-MODE + B generator	Outputs 9V in other than AM and FM modes.
Q35	Per-MODE + B generator	Outputs 9V in FM mode.
Q36	BUSY LED driver	ON when lighted.
Q37	Center detection switch	ON when center is detected in AM or FM mode, OFF otherwise.
Q38	BUSY STOP switch	ON when BUSY state is removed.
Q39	REC OUT amplifier	
Q40	IF filter switch circuit driver	Outputs 9V during N operation.
Q41	IF filter switch circuit driver	Outputs 9V during M1 operation.
Q42	IF filter switch circuit driver	Outputs 9V during M2 operation.
Q43	IF filter switch circuit driver	Outputs 9V during W operation.
Q44	SELECTIVITY cancel switch	Outputs 9V in FM mode.
D1	IF input switch	ON for HF.
D2	IF input switch	ON for VHF.
D3	NB detector	
D4	Reverse current blocking	
D5~10	M2 filter switch	
D11~16	M1 filter switch	
D17~22	N filter switch	
D23	BFO signal input switch	ON in other than AM and FM modes.
D24~27	Ring detector	
D28	AGC detector	
D29	SSB squelch cancel in FM mode	Pulls SSQ down from FMG.
D30	SSB squelch reverse current blocking	ORed with FM squelch output (D34).
D31	AGC detector	
D32	FM squelch noise detector	
D33	Reverse current blocking	
D34	FM squelch output reverse current blocking	ORed with SSB squelch output (D30).
D35	Reverse current blocking	
D36	Center detection cancel in other than AM and FM mode	Pulls down center detection enabling level to "L".
D37	Mute signal reverse current blocking	Isolates microprocessor system from squelch system.
D38~40	M2 filter selection ORing circuit	
D41	M1 filter de-selection signal	
D42	M1 filter selection ORing circuit	
D43	M1 filter de-selection ORing circuit	
D44	N filter selection signal	
D45~47	N filter de-selection ORing circuit	
D48~51	Reverse current blocking (SELECTIVITY switch)	
D52~56	Reverse current blocking (per-MODE "L" signal system)	
D57,58,60	Reverse current blocking (per-MODE "L" signal system)	Provides an AND that produces "L" in other than AM and FM modes.
D59	AMG line reverse current blocking	
D61	FMG line reverse current blocking	
D62,63	Reverse current blocking (per-MODE "L" signal system)	Provides an AND that produces "L" in other than AM mode.
D64	Voltage clamper	Prevents negative voltage to IC2.

## DESCRIPTION OF COMPONENTS

### PLL UNIT (X50-3030-00)

Component	Function	Operation/condition
IC1	Reference frequency dividers (1/2)	① 9MHz input    ⑧、⑨ 9MHz output ⑤ 18MHz input    ⑬ 4.5MHz output
IC2	PLL1 (VCO's least significant digit PLL)	② Unlock line; "L" when unlocking. ③ 9MHz input (1/2 fSTD) ⑧ VCO lock voltage output. ⑨~⑬ Frequency division ratio setting inputs. ⑯ 90.000~99.998MHz input (CW : 89.840~99.838MHz, FSK : 90.458~100.456MHz)
IC3	Frequency divider (1/20)	④ 90.000~99.998MHz input (CW : 89.840~99.838MHz, FSK : 90.458~100.456MHz) ⑧ 4.5000~4.9999MHz output (CW : 4.4920~4.9919MHz, FSK : 4.5229~5.0228MHz)
IC4	Frequency divider (1/10)	① 4.5000~4.9999MHz input (CW : 4.4920~4.9919MHz, FSK : 4.5229~5.0228MHz) ⑫ 450.00~499.99kHz output (CW : 449.20~499.19kHz, FSK : 452.29~502.28kHz)
IC5	Mixer (adding VCO1 to fBFO)	① 9.2800~9.32999MHz output ② 8.83MHz input (fBFO) ⑤ 450.00~499.99kHz input (CW : 449.20~499.19kHz, FSK : 452.29~502.28kHz)
IC6	Mixer (adding IC5 output to fBFO)	① 58.5625~58.61249MHz output ② 49.2825MHz input (fHET) ⑤ 9.2800~9.32999MHz input
IC7	Mixer (compositing PLL1 and PLL2 signals)	① 37.55~38.50MHz or 36.55~37.50MHz output (PLL2 1F) ② 58.5625~58.61249MHz input ⑤ 96.1125~97.11249MHz or 95.1125~96.11249MHz input
IC8	PLL2 (VFO's middle digit PLL)	① 9MHz input (1/2 fSTD) ⑤ VCO lock voltage output. ⑦ PLL2 unlock output; "L" when muting.
IC9	PLL2 pre-scaler	② 37.55~38.50MHz or 36.55~37.50MHz input (PLL2 1F)
IC10	Mixer (compositing PLL2 and PLL3 signals)	① 38.0~20.0MHz, 18.0~7.0MHz output (PLL3 1F) ② 58.1125~88.1125MHz input ⑤ 96.1125~97.11249MHz or 95.1125~95.11249MHz input (fVCO2)
IC11	PLL3 pre-scaler	③ 38.0~20.0MHz, 18.0~7.0MHz input (PLL3 1F)
IC12	PLL3 (VFO's final HF band PLL)	① 9MHz input (1/2 fSTD) ⑤ PLL3 output. ⑦ Unlock line.
IC13	PLL3 low-pass filter	②、⑧ VCO voltage output for RF unit (3~6V) ③、⑦ PLL3 VCO lock voltage input.
IC14	PLL4 (BFO PLL)	② Unlock line; "L" when unlocking. ③ 4.5MHz input (1/4 fSTD) ⑧ VCO lock voltage output. ⑨~⑬ Frequency division ratio setting inputs. ⑯ 33.7~34.3MHz, VCO4 oscillation signal input.

## DESCRIPTION OF COMPONENTS

Component	Function	Operation/condition
IC15	Frequency divider (1/20)	④ Switched frequency input USB/CW : 33.7MHz, AM/FM : 34.0MHz, LSB/FSK : 34.3MHz ⑧ Divided frequency output USB/CW : 1.685MHz, AM/FM : 1.700MHz, LSB/FSK : 1.715MHz
IC16	Frequency divider (1/10)	① Switched frequency input USB/CW : 1.685MHz, AM/FM : 1.700MHz, LSB/FSK : 1.715MHz ⑫ Divided frequency output USB/CW : 168.5kHz, AM/FM : 170.0MHz, LSB/FSK : 171.5kHz.
IC17	Mixer	① BFO frequency output USB/CW : 8.8315MHz, AM/FM : 8.8300MHz, LSB/FSK : 8.8285MHz (BFO) ② 9MHz input (1/2 fSTD) ⑤ Switched frequency input USB/CW : 168.5kHz, AM/FM : 170.0kHz, LSB/FSK : 171.5kHz
IC18	5V AVR	Input : 9.0V, Output : 5.0V.
IC19	9V AVR	Input : 13.6V, Output : 9.0V.
Q1	Reference frequency crystal oscillator	18MHz.
Q2	18MHz buffer amplifier	
Q3	18MHz buffer amplifier	E-G : 800Vrms
Q4	PLL1 VCO	90.000~99.998MHz
Q5	VCO1 (PLL1) buffer amplifier	(CW : 89.840~99.838MHz, FSK : 90.458~100.456MHz).
Q6	PLL2 IF signal buffer amplifier	37.55~38.50MHz or 36.55~37.50MHz.
Q7	PLL2 VCO	96.1125~97.11249MHz or 95.1125~96.11249MHz.
Q8~10	VCO2 (PLL2) buffer amplifier	
Q11~14	PLL3 IF signal buffer amplifier	38.0~20.0MHz, 18.0~7.0MHz.
Q15	PLL4 VCO	33.7~34.3MHz.
Q16	VCO4 (PLL4) buffer amplifier	
Q17,18	BFO buffer amplifier	8.83MHz.
Q19	VC-20 reference frequency buffer amplifier	9MHz (1/2 fSTD)
Q20	HET buffer amplifier	49.2825MHz.
Q21	VFO buffer amplifier	58.1125~88.1125MHz.
Q22	VPL buffer amplifier	96.1125~97.11249MHz or 95.1125~96.11249MHz, VC-20 lower digit signal.
Q23	Lower digit unlock signal waveform shaping	"H" when unlocking.
Q24	(PLL1 + PLL2 + PLL3)	"L" when unlocking.
Q25	HF-band PLL unlock signal waveform shaping	"H" when unlocking.
D1	Wired OR circuit	Composites lower digit PLL unlock signals.
D2,3	PLL1 VCO frequency variation element	Varicap diode ITT310TE.
D4	PLL2 VCO frequency variation element	Varicap diode 1SV153.
D6	Wired OR circuit	Composites unlock signals.
D7	PLL3 (IC12) power supply	+ 5V zener diode.
D8	Wired OR circuit	Composites lower digit PLL unlock signals.
D9,10	PLL4 VCO frequency variation element	Varicap diode 1SV153.
D11	BFO signal switching	
D12	VC-20 standard signal switching	
D13	VC-20 lower digit signal switching	
D14,15	Unlock signal waveform shaping	
D16~19	Final PLL data HF/VHF switching	

## DESCRIPTION OF COMPONENTS

### CONTROL UNIT (X53-3020-XX)

Component	Function	Operation/condition
IC1	Microprocessor (N-MOS)	8-bit microprocessor (see the circuit description).
IC2	I/O port (C-MOS)	Bus interface I/O ports, all are set up as output ports (see the I/O port table).
IC3	System reset	Generates a reset signal, which produces microprocessor operation and back-up timings, during power voltage rise and fall when the unit is turned on and off.
IC4	Inverter (C-MOS)	1/6, 2/6 : Beep tone oscillator. 3/6, 4/6 : System clock oscillator (1.99MHz). 5/5, 6/6 : System reset signal waveform shaping.
IC5~7	Encoder waveform shaping (C-MOS)	Converts the 2-phase encoder clock signal to the U/D direction and count clock pulse signals.
IC50	Static RAM (C-MOS)	Provides a 2K bytes x 8 bits area for working with or creating microprocessor data such as VFO and memory, etc. Its contents are backed up by the system reset signal.
IC51	Address decoder (TTL)	Divides the CPU address signal into the chip select signals for each memory IC; the 64K byte memory area is divided into eight 8K byte blocks.
IC52	ROM (N-MOS)	Contains control programs (including external control programs).
IC53	I/O port (C-MOS)	The bus interface I/O ports which are used as the key-scan matrix and for static input (see the I/O port table).
IC54 (Optional)	Serial I/O port (N-MOS)	The I/O port for external control by the microprocessor which generates an interrupt to the CPU each time a character is received.
IC55 (Optional)	Serial I/O port baud rate frequency divider (C-MOS)	Generates the clock signals of various baud rates for the serial I/O port.
IC56	Serial buffer and serial I/O baud rate clock oscillator (TTL)	1/6, 6/6 : Serial I/O port baud rate clock oscillator. 2/6, 3/6 : Serial input data buffer. 4/6, 5/6 : Serial output data buffer.
IC57	Real-time clock (C-MOS)	Provides a clock which continues to serve also in back-up mode.
Q1	Timer relay switching	Turns the power and timer switches on and off to allow the receiver section to be turned on and off according to the timer; energizes the relay when "H".
Q2	FM mode signal buffer	Active in FM mode and the open collector connection output drives the IF unit FM mode signal and the "FM" LED on the keyboard ass'y.
Q3	FSK mode signal buffer	Active in FSK mode and the open collector connection output drives the IF unit FSK mode signal and the "FSK" LED on the keyboard ass'y.
Q4	AM mode signal buffer	Active in AM mode and the open collector connection output drives the IF unit AM mode signal and the "AM" LED on the keyboard ass'y.
Q5	CW mode signal buffer	Active in CW mode and the open collector connection output drives the IF unit CW mode signal and the "CW" LED on the keyboard ass'y.
Q6	USB mode signal buffer	Active in USB mode and the open collector connection output drives the "USB" LED on the keyboard ass'y.
Q7	LSB mode signal buffer	Active in LSB mode and the open collector connection output drives the "LSB" LED on the keyboard ass'y. The USB and LSB signals are mixed with a diode switch to produce the IF unit SSB mode signal.
Q14	ANT1 LED driver	Drives the ANT1 LED while in HF band reception.
Q15	ANT2 LED driver	Drives the ANT2 LED while in HF band reception and also serves as the signal to drive the ANT1/ANT2 switch relay.
Q16	MSCB LED driver	Drives the MSCB LED during memory scrolling.

## DESCRIPTION OF COMPONENTS

Component	Function	Operation/condition
Q17	LOCK LED driver	Drives the F.LOCK LED when F.LOCK is enabled.
Q50	RAM back-up control	Puts the RAM in back-up mode when power is turned off.
D1,2	SSB mode signal compositing	Composites the LSB and USB mode signals to produce the IF unit SSB mode signal.
D3,4	Encoder count pulse compositing	Shapes the 2-phase encoder count pulse waveform to provide the encoder count pulse.
D5~8	Encoder count pulse compositing	Composites quadrupled count pulse.
D9	Beep switching	Switches the beep oscillator ON/OFF with the beep pulse. "H" input enables the BEEP output.
D51,52	Power switching	Provides power switching for RAM back-up.
D53,54	ROM chip select signal compositing	Composites select signals for two 8K byte blocks to provide the 16K byte ROM select signal.
D65	Expansion feature switch	Selects either the 10Hz or 100Hz display; conduction displays 10Hz and cut-off displays 100Hz.
D66	Expansion feature switch	Controls the mode buzzer; conduction gives a series of Morse code sounds and cut-off gives a single short sound.
D67	Expansion feature switch	Controls the FM step when STEP ON; conduction : 2.5kHz, cut-off : 500Hz.
D68	Expansion feature switch	Controls BUSY STOP; conduction enables BUSY STOP in AM and FM modes only and cut-off enables BUSY STOP in all modes.
D69	Expansion feature switch	Controls memory search; conduction disables memory search and cut-off enables memory search.
D70,71	Expansion feature switch	Not used (reserved for future use).
D72	Expansion feature switch	Control memory control; conduction protects memory and cut-off does not protect memory.
D85,86	Power switching	Switches power for clock IC back-up.

### DISPLAY UNIT (X54-3010-00)

Component	Function	Operation/condition
IC1	Serial input high voltage resisting fluorescent tube driver	Converts serial data from the control unit to a parallel form and drives the fluorescent display tube driver. ①~⑦、⑮~⑳ High voltage resisting output ports. ⑨ Dimmer blanking input. ⑩ Latch pulse. ⑪ Serial data input. ⑫ Serial clock input.
IC2	A/D converter	Converts the analog voltage input to a digital value and outputs it to the CPU. ④ IF shift                      ⑥ Scan speed ⑤ Carrier point correction   ⑦ Scan resume time.
IC3	Clock frequency divider	Divides the CPU serial clock and 1MHz data rate to the clock and 500kHz data rate for IC1.
Q1	Dp driver	Drives the decimal point Dp of the fluorescent tube; "H" input lights up.
Q2	Red character driver	Drives the red characters of the fluorescent tube with an 8V supply; "H" input lights the red characters.
Q3	Inverter	Reverses the red character lighting level; "L" input produces the lighting level.
Q4,5	DC-DC converter oscillator	Generates the intermediate AC voltage for the fluorescent tube drive DC-DC converter.
D1~4	High voltage rectifier	The rectifier bridge for the fluorescent tube drive negative voltage.
D5	Negative voltage supply	Supplies -5V to the IF unit.
D6	Filament bias voltage generator	Supplies the bias voltage for the fluorescent display tube filament.

# R-5000

## DESCRIPTION OF COMPONENTS

### AGC (X59-3010-00)

Component	Function	Operation/condition
IC1	AGC time-constant selection control	Determines a time constant according to the used mode and AGC switch position.
IC2	AGC time-constant circuit connection switch	"H" control input connects the circuit and "L" disconnects the circuit.

### S METER (X59-3020-00)

Component	Function	Operation/condition
Q1	External mute control switch	ON when muting.
Q2	S meter driver	
Q3,4	AGC driver	
Q5	Voltage buffer	
D1	Reverse current blocking	
D2	AGC driver (Q3,4) temperature compensation	

### NOTCH (X59-3030-00)

Component	Function	Operation/condition
IC1	Active BPF NOTCH gain compensation amplifier	

### SELECT (X59-3040-00)

Component	Function	Operation/condition
IC1	Squelch gate (1/4) NOTCH module output selection switch (2/4, 3/4, 4/4)	Control input "H" : open, "L" : muting.
Q1,2	NOTCH mode control	Determines the operation mode according to the used mode and NOTCH switch position.
Q3	NOTCH LED driver	Sinks the lighting current.
D1	CWG line reverse current blocking	

## PARTS LIST

### CAPACITORS

CC 45 TH 1H 220 J  
 1 2 3 4 5 6

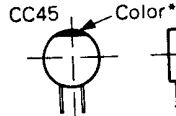

#### Capacitor value

1 0 3 = 0.01μF

- 0 1 0 = 1pF
- 1 0 0 = 10pF
- 1 0 1 = 100pF
- 1 0 2 = 1000pF = 0.001μF

2 2 0 = 22pF  
 1st number | Multiplier  
 2nd number

- 1 = Type ..... ceramic, electrolytic, etc.
- 2 = Shape ..... round, square, etc.
- 3 = Temp. coefficient
- 4 = Voltage rating
- 5 = Value
- 6 = Tolerance

#### Temperature Coefficient

1st Word	C	L	P	R	S	T	U
Color*	Black	Red	Orange	Yellow	Green	Blue	Violet
ppm/°C	0	-80	-150	-220	-330	-470	-750

2nd Word	G	H	J	K	L
ppm/°C	± 30	± 60	± 120	± 250	± 500

Example CC45TH = -470 ± 60 ppm/°C

#### Tolerance

Code	C	D	G	J	K	M	X	Z	P	No code
(%)	± 0.25	± 0.5	± 2	± 5	± 10	± 20	+ 40 - 20	+ 80 - 20	+ 100 - 0	More than Less than 10μF-10~+50 4.7μF-10~+75

Code	B	C	D	F	G
(pF)	± 0.1	± 0.25	± 0.5	± 1	± 2

Less than 10 pF

#### Rating voltage

2nd word	A	B	C	D	E	F	G	H	J	K	V	
1st word	0	1.0	1.25	1.6	2.0	2.5	3.15	4.0	5.0	6.3	8.0	-
1	10	12.5	16	20	25	31.5	40	50	63	80	35	-
2	100	125	160	200	250	315	400	500	630	800	-	-
3	1000	1250	1600	2000	2500	3150	4000	5000	6300	8000	-	-

#### Chip capacitors

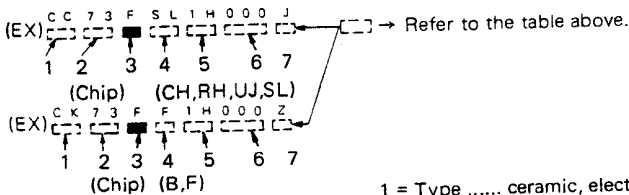

#### Dimension

Dimension code	L	W	T
Empty	5.6 ± 0.5	5.0 ± 0.5	Less than 2.0
E	3.2 ± 0.2	1.6 ± 0.2	Less than 1.25
F	2.0 ± 0.3	1.25 ± 0.2	Less than 1.25

#### Dimension

Dimension code	L	W	T	Wattage
E	3.2 ± 0.2	1.6 ± 0.2	0.57	2B
F	2.0 ± 0.3	1.25 ± 0.2	0.45	2A

#### Rating wattage

Cord	Wattage	Cord	Wattage	Cord	Wattage
2A	1 10W	2E	1 4W	3A	1W
2B	1 8W	2H	1 2W	3D	2W
2C	1 6W				

#### Dimension

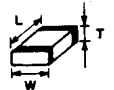

### RESISTORS

#### Chip resistor (Carbon)

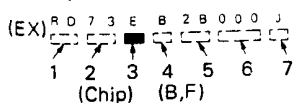

#### Carbon resistor (Normal type)

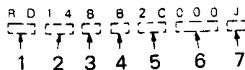

- 1 = Type ..... ceramic, electrolytic, etc.
- 2 = Shape ..... round, square, etc.
- 3 = Dimension
- 4 = Temp. coefficient
- 5 = Voltage rating
- 6 = Value
- 7 = Tolerance.

# R-5000

## PARTS LIST

### SEMICONDUCTOR

N : New part

Item	Re- marks	Part No.	
<b>Diode</b>		1N60	
		1S1007	
		1S1555	
		1S1587	
	N	1SS132	
		1SS133	
		1SS141VE	
		BA282	
	N	D5S4M	
		DAP401	
	N	DAP601	
		MA858	
		MC911	
		MC921	
	MC931		
	S15VB10		
	US1090		
	V06B		
<b>Varicap Diode</b>		1SV153	
		ITT310TE	
<b>Chip Diode Zener Diode</b>		DAN202(K)	
		MTZ3.9JB	
		MTZ5.1JA	
		MTZ7.5JA	
	MTZ9.1JC		
	UZ3.31BCA		
<b>Thermister</b>		112-202-2	
		112-501-2	
<b>TR</b>		2SB698(E,F)	
		2SC1907	
		2SC1959(Y)	
		2SC2053	
		2SC2458(Y)	
		2SC2459(BL)	
		2SC2668(Y)	
		2SC2787(L)	
		2SC3113(B)	
		2SA1162(Y)	
		2SC2712(Y)	
	<b>Chip TR</b>		DTA114ES
			DTA124EK
			DTA124ES
		DTA144ES	
		DTC114ES	
		DTC124ES	

Item	Re- marks	Part No.	
<b>FET</b>	N	DTC143ES	
		DTC144ES	
		DTC144WK	
		DTC144WS	
		2SK125	
		2SK161(GR)	
		2SK192A(GR)*J	
		3SK73(Y)	
	<b>Chip FET</b>		2SK211(GR)
	<b>IC</b>	N	AN78M09
			AN78N05
		N	AN78N09
			BA718
		M5M82C55AP-5	
		M54459L	
		MB3713	
		MB4052	
		MB8418-20LP-GRA	
		MB87006	
N		MBM27128-25JB1	
		MC6147C	
		MN6147C	
N		MSM6242RS	
	NE555P		
	NJM2903S		
	NJM4558M		
	NJM4558S		
	PST520D		
	SN74S74N		
	SN74LS73AN		
	SN74LS90N		
	SN74LS138N		
	SN74LS145N		
	SN16913P		
	SN7404N		
	TA78010AP		
N	TC4001BF		
	TC4011BP		
	TC4013BP		
	TC4030BP		
	TC4066BF		
	TC4066BP		
	TC4069UBP		
	TC4071BP		
	UA7805		
N	μPB551C		
	μPC577H		
	μPD6300C		
	μPD7800G		

## PARTS LIST

× New Parts

Parts without Parts No. are not supplied.

Les articles non mentionnés dans le Parts No. ne sont pas fournis.

Telle ohne Parts No. werden nicht geliefert.

Ref. No. 参照番号	Address 位置	New Parts 新	Parts No. 部品番号	Description 部品名 / 規格	Desti- nation 仕 向	Re- marks 備考
<b>R-5000</b>						
1	1B	*	A01-1019-02	CASE (A)UPPER		
2	3A	*	A01-1020-02	CASE (B)LOWER		
3	2C	*	A20-2594-13	PANEL ASSY		
6	2G,2J	*	A22-0750-02	SUB PANEL		
7	1E,2E	*	A23-1494-03	REAR PANEL	K1	
7	1E,2E	*	A23-1495-03	REAR PANEL	M1T1W1	
7	1E,2E	*	A23-1495-03	REAR PANEL	W2X1	
-	-	*	A20-2595-13	PANEL		
-	-	*	A21-1510-04	DRESSING PANEL		
△ 8	2D	*	B40-3673-04	MODEL NAME PLATE	K1	
△ 8	2D	*	B40-3674-04	MODEL NAME PLATE	M1W1W2	
△ 8	2D	*	B40-3675-14	MODEL NAME PLATE	T1	
9	1A,3A	*	B41-0338-04	CAUTION SHEEL	K1	
10	2D	*	B41-0384-04	CAUTION SHEEL	K1	
11	1A	*	B05-0711-14	SARAN NET (SP)		
12	2C	*	B43-1071-04	BADGE	K1M1W1	
12	2C	*	B43-1071-04	BADGE	W2X1	
12	2C	*	B43-1073-14	BADGE	T1	
13	1M	*	B50-8101-00	INSTRUCTION MANUAL	K1M1W1	
13	1M	*	B50-8101-00	INSTRUCTION MANUAL	W2X1	
13	1M	*	B50-8103-00	INSTRUCTION MANUAL	T1	
14	1M	*	B46-0410-10	WARRANTY CARD	K1	
15	1K	*	B41-0525-04	CAUTION SHEEL	K1	
M101	2I	*	B31-0659-15	S METER		
PL101	1G	*	B30-0817-15	PILOT LAMP (14V,80MA)		
△ C101,102		*	C91-1075-05	CERAMIC 470PF		
△ C103		*	C91-0647-05	CERAMIC 0.01UF P		
△ 16	1L	*	E30-1305-15	AC POWER CORD	M1	
△ 16	1L	*	E30-1328-15	AC POWER CORD	T1	
△ 16	1L	*	E30-1329-05	AC POWER CORD	W1W2	
△ 16	1L	*	E30-1342-05	AC POWER CORD	X1	
△ 16	1L	*	E30-2071-05	AC POWER CORD	K1	
18	2D	*	E23-0473-04	TERMINAL (ANT GND)		
-	-	*	E40-3238-05	PIN CONNECTOR (3P)		
-	-	*	E40-5068-05	PIN CONNECTOR (11P)		
J101	2D	*	E04-0164-05	RF COAXIAL CABLE RECEPTACLE		
△ J102	2E	*	E03-0166-05	AC INLET		
J103	2E	*	E20-0383-05	TERMINAL BOARD (3P)		
21	1D	*	F02-0431-04	HEAT SINK		
24	1K	*	F11-1004-13	SHIELDING COVER(CONTROL)		
28	2E	*	F19-0649-14	BLIND PLATE		
29	2E	*	F19-0610-04	CONNECTOR MASK		
△ 32		*	F29-0072-05	INSULATOR (AC)		
△ 35	1A	*	F20-0562-14	INSULATING BOARD(DISP-CONT)	K1	
△ -		*	F05-4021-05	FUSE (4A)	M1	
△ -		*	F05-4022-05	FUSE (4A)	T1W1W2	
△ -		*	F05-4024-05	FUSE (4A)	X1	
△ -		*	F05-4024-05	FUSE (4A)		
-		*	F11-1043-14	SHIELDING COVER(RF)		
-		*	F11-1048-04	SHIELDING COVER(VS-1)		
-		*	F20-0521-04	INSULATING BOARD(LITHIUM BATT)		

# PARTS LIST

× New Parts

Parts without Parts No. are not supplied.

Les articles non mentionnés dans le Parts No. ne sont pas fournis.

Telle ohne Parts No. werden nicht geliefert.

Ref. No. 参照番号	Address 位置	New Parts 新	Parts No. 部品番号	Description 部品名 / 規格	Desti- nation 仕向	Re- marks 備考
-		*	F20-0561-04	INSULATING BOARD(VS-1)		
36	2C		G02-0505-05	KNØB FIXED SPLING		
37	1H		G10-0610-04	FELT (FIP)		
38	2J		G10-0638-14	FELT (LED)		
39	3A, 3B		G53-0507-04	PACKING (CASE SIDE)		
40	2C		G13-0830-04	CUSHION (CLOCK)		
41	2C	*	G16-0511-04	TURNTABLE SHEET(PANEL)		
-			G10-0639-04	FELT (S METER)		
42	2L		H12-1315-04	CUSHION		
43	2L	*	H10-2621-02	PACKING FIXTURE(F)		
44	2M	*	H10-2622-02	PACKING FIXTURE(R)		
45	2L		H20-1410-03	PROTECTIVE COVER		
46	1L		H25-0105-04	PROTECTIVE BAG (AC CORD)		
48	3L	*	H01-8030-04	CARTON BOX (INSIDE)	K1M1W1	
48	3L	*	H01-8030-04	CARTON BOX (INSIDE)	W2X1	
48	3L	*	H01-8031-04	CARTON BOX (INSIDE)	T1	
49	3A		J02-0442-04	FOOT (X2)F		
50	1G		J21-2779-14	MOUNTING HARDWARE(PILØT LAMP)		
51	1K		J21-4177-14	MOUNTING HARDWARE(PRINT BOARD)		
52	1A	*	J21-4208-14	MOUNTING HARDWARE(SP)		
53	3A		J21-4208-04	MOUNTING HARDWARE(ASSIST FOOT)		
54	2F		J30-0526-04	SPACER (SLIDE SW)		
55	1F		J32-0765-04	HEX BOSS (6.5MM)		
56	2G		J32-0782-04	HEX BOSS (11MM)		
57	1G, 1H		J32-0792-04	HEX BOSS (10MM)		
58	1H		J32-0793-04	HEX BOSS (11MM)		
59	1J, 1K		J32-0794-04	HEX BOSS (5MM)		
60	1G	*	J32-0800-04	HEX BOSS (11.5MM)		
61	2E		J42-0442-05	AC POWER CORD BUSHING		
62	3B		J02-0323-05	FOOT (X2)R		
63	3A		J02-0440-04	ASSISTANT FOOT		
64	1A, 2A		J02-0441-05	FOOT (X4)		
-			J19-1363-05	LEAD HOLDER		
-			J61-0307-05	WIRE BAND		
65	3B		K01-0407-05	HANDLE		
66	2C		K21-0778-02	KNØB (MAIN)		
67	2C		K23-0710-04	KNØB (INSIDE)		
68	2C		K23-0753-04	KNØB (SELECTIVITY)		
69	22		K23-0782-04	KNØB (RF ATT)		
70	2C		K29-0741-34	KNØB ASSY (OUT SIDE)		
71	1C		K29-0758-14	PUSH KNØB (POWER)		
72	2C		K29-0782-05	SLIDE KNØB (CLOCK)		
73	2D		K29-3001-14	PUSH KNØB (NOTCH)		
74	2C		K29-3002-14	PUSH KNØB (VOICE)		
△	T101	*	L01-8051-05	POWER TRANSFORMER	K1	
△	T101		L01-8306-05	POWER TRANSFORMER	M1T1W1	
△	T101		L01-8306-05	POWER TRANSFORMER	W2X1	
80	2A, 2B		N10-2030-46	HEXAGON NUT (SP)		
81	2C		N15-1030-41	FLAT WASHER (PANEL)		
82	2C		N19-0637-04	FLAT WASHER (MAIN KNØB)		
-			N89-2606-45	BINDING HEAD TAPTITE SCREW		
A	2E, 2F		N09-0256-05	GND SCREW (SUB PANEL)		

E: Scandinavia & Europe H: Audio Club K: USA P: Canada W: Europe

A: Saudi Arabia T: England U: PX(Far East, Hawaii)

# PARTS LIST

× New Parts

Parts without Parts No. are not supplied.

Les articles non mentionnés dans le Parts No. ne sont pas fournis.

Telle ohne Parts No. werden nicht geliefert.

Ref. No. 参照番号	Address 位置	New Parts 新	Parts No. 部品番号	Description 部品名 / 規格	Desti- nation 仕向	Re- marks 備考
B	2I		N09-0644-04	BIND SCREW (METER,KEY BOARD)		
C	1A,2E		N35-3006-41	BINDING HEAD MACHINE SCREW		
D	1C,1D		N09-2013-05	SCREW (PT)		
F	1F,1G		N32-2606-46	FLAT SCREW (SW UNIT)		
G	1C,2D		N32-3004-46	FLAT SCREW (SUB PANEL)		
H	1F		N32-3006-46	FLAT SCREW (PILOT LAMP)		
K	2E,1H		N35-2605-41	BIND SCREW (DISP,CONT)		
L	2C,2D		N35-3006-45	BINDING HEAD MACHINE SCREW		
M	1D,2D		N87-2606-46	BRAZIER HEAD TAPTITE SCREW		
N	1D,2E		N87-3006-41	BRAZIER HEAD TAPTITE SCREW(PNL)		
P	3A		N87-3008-41	BRAZIER HEAD TAPTITE SCREW		
Q	1D		N87-3016-46	BRAZIER HEAD TAPTITE SCREW		
R	2E		N35-2606-41	BIND SCREW (SW,ETC.)		
U	1K		N09-0658-04	ROUND SCREW (SHIELD COVER)		
△	R101,102 R103		RD14BB2E103J R92-0173-05	RD 10K J 1/4W RC 2.2M M 1/2W	K1	
△	S101		S29-2406-05	ROTARY SWITCH		M1T1W1
△	S101		S29-2406-05	ROTARY SWITCH		W2X1
	SP101		T07-0222-15	LOUDSPEAKER(FULLRANGE)		
△	D101		S15VB10	DIODE		
△	IC101		AN78M09	IC		
	86		W02-0373-25	ENCODER ASSY		
	87		W03-2005-15	KEYBOARD ASSY		
△	-	*	W09-0364-05	LITHIUM BATTERY		
	92	*	X41-3000-00	SWITCH UNIT		
	93	*	X43-3000-00	AVR UNIT		
	94	*	X44-3010-00	RF UNIT		
	95	*	X48-3000-00	IF UNIT		
	96	*	X50-3030-00	PLL UNIT		
	97	*	X53-3020-11	CONTROL UNIT		K1M1T1
	97	*	X53-3020-11	CONTROL UNIT		W1
	97	*	X53-3020-61	CONTROL UNIT		W2
	97	*	X53-3020-71	CONTROL UNIT		X1
	98	*	X54-3010-00	DISPLAY UNIT		
<b>SWITCH UNIT (X41-3000-00)</b>						
C1			CQ92M1H272K	MYLAR 2700PF K		
C6			CE04EW1H010M	ELECTRO 1.0UF 50WV		
C7			CE04EW1E470M	ELECTRO 47UF 25WV		
C9	-11		CK45E2H472P	CERAMIC 4700PF P		
C20			CQ92M1H103K	MYLAR 0.010UF K		
-			E23-0453-05	TERMINAL		
-			E40-3237-05	PIN CONNECTOR (2P)		
-			E40-3238-05	PIN CONNECTOR (3P)		
-			E40-3239-05	PIN CONNECTOR (4P)		
-			E40-3240-05	PIN CONNECTOR (5P)		
-			E40-3241-05	PIN CONNECTOR (6P)		
-			E40-5066-05	PIN CONNECTOR (7P)		
J1	2F		E11-0418-05	PHONE JACK (PHONES)		
J2	2F		E11-0414-05	PHONE JACK (REC)		
J3	2E		E06-0754-05	DIN CONNECTOR(REMOTE)		
J4	2E		E06-0656-05	DIN CONNECTOR(6P) ACC1		

# R-5000

## PARTS LIST

\* New Parts

Parts without Parts No. are not supplied.

Les articles non mentionnes dans le Parts No. ne sont pas fournis.

Teile ohne Parts No. werden nicht geliefert.

Ref. No. 参照番号	Address 位置	New Parts 新	Parts No. 部品番号	Description 部品名 / 規格	Desti- nation 仕向	Re- marks 備考
R23			RS14KB3A470J	FL-PROOF RS 47 J 1W		
VR1	1G	*	R24-9406-05	POTENTIOMETER (SQ, NOTCH)		
VR2 ,3			R12-1069-05	TRIMMING PQT. (4.7K)		
VR4	2H		R19-3420-05	POTENTIOMETER (AF, RF)		
VR5	2H	*	R19-9410-05	POTENTIOMETER (NB, IF SHIFT)		
VR6			R12-1066-05	TRIMMING PQT. (1K)		
VR7			R12-1069-05	TRIMMING PQT. (4.7K)		
S1	1G	*	S29-1435-05	ROTARY SWITCH (SELECTIVITY)		
S2	2H		S01-2431-05	ROTARY SWITCH (RF ATT)		
S3	1G		S31-2405-05	SLIDE SWITCH (CLOCK)		
S4	1G		S40-2441-15	PUSH SWITCH (VOICE)		
S5	1G		S40-2440-15	PUSH SWITCH (DIM, ETC)		
S6 ,7	1G		S40-2441-15	PUSH SWITCH (VOICE)		
S8 ,9	1G		S40-2440-15	PUSH SWITCH (DIM, ETC)		
S10	1F	*	S40-2457-05	PUSH SWITCH (POWER)		
D1	-8		1SS133	DIODE		
IC1			NE555P	IC		
<b>AVR UNIT (X43-3000-00)</b>						
C1			C90-2047-05	ELECTRO 1500UF 25WV		
C4			C91-1008-05	CERAMIC 0.022UF K		
C5			CE04EW1E220M	ELECTRO 22UF 25WV		
C8			CE04EW1E220M	ELECTRO 22UF 25WV		
C9			C91-1008-05	CERAMIC 0.022UF K		
C10			CE04EW1E220M	ELECTRO 22UF 25WV		
C11			CE04EW1A470M	ELECTRO 47UF 10WV		
C12			C91-1008-05	CERAMIC 0.022UF K		
-			E23-0453-05	TERMINAL		
CN1			E40-3239-05	PIN CONNECTOR (4P)		
CN2			E40-3240-05	PIN CONNECTOR (5P)		
CN3			E40-3242-05	PIN CONNECTOR (7P)		
CN4			E40-3238-05	PIN CONNECTOR (3P)		
CN5			E08-0272-05	RECTANGULAR RECEPTACLE (2P)		
CN6			E40-3240-05	PIN CONNECTOR (5P)		
CN7			E08-0373-05	RECTANGULAR RECEPTACLE (3P)		
CN8			E40-3238-05	PIN CONNECTOR (3P)		
-		*	F02-0429-04	HEAT SINK		
-			J13-0055-05	FUSE HOLDER		
-			N09-0641-05	SCREW		
-			N35-3006-46	BINDING HEAD MACHINE SCREW		
R4			RS14KB3A101J	FL-PROOF RS 100 J 1W		
R5 ,6			R92-0514-05	FUSE RESIST 4.7 J 1/4W		
R7 ,8		*	R92-0513-05	FUSE RESIST 10 G 1/4W		
RL1		*	S51-2418-05	RELAY		
D1		*	D5S4M	DIODE		
D2			V06B	DIODE		
D3			1SS133	DIODE		
D4			1S1555	DIODE		
D5 ,6			V06B	DIODE		
D7			MTZ9.1JC	ZENER DIODE		
D8			UZ3.3BCA	ZENER DIODE		

## PARTS LIST

× New Parts

Parts without Parts No. are not supplied.

Les articles non mentionnés dans le Parts No. ne sont pas fournis.

Teile ohne Parts No. werden nicht geliefert.

Ref. No. 参照番号	Address 位置	New Parts 新	Parts No. 部品番号	Description 部品名 / 規格	Desti- nation 仕向	Re- marks 備考
△ D9 IC1 IC2 Q1 △ Q2		*	1SS133 TA78D10AP UA7805 DTC124ES 2SC1959(Y)	DIODE IC (VOLTAGE REGULATOR / +10V) IC (AVR) DIGITAL TRANSISTOR TRANSISTOR		
<b>RF UNIT (X44-3010-00)</b>						
C3 C7 C8 C10 C11	,4   ,9		CC45CH1H390J CK45B1H102K CC45CH1H390J CC45CH1H220J CC45CH1H120J	CERAMIC 39PF J CERAMIC 1000PF K CERAMIC 39PF J CERAMIC 22PF J CERAMIC 12PF J		
C12 C16 C18 C19 C20	 ,17		CE04EW1H010M CE04EW1H010M C91-0117-05 CQ92M1H392K CQ92M1H272K	ELECTRO 1.0UF 50WV ELECTRO 1.0UF 50WV CERAMIC 0.01UF K MYLAR 3900PF K MYLAR 2700PF K		
C21 C22 C23 C24 C25			CQ92M1H562K CQ92M1H222K CQ92M1H392K CQ92M1H152K CQ92M1H122K	MYLAR 5600PF K MYLAR 2200PF K MYLAR 3900PF K MYLAR 1500PF K MYLAR 1200PF K		
C26 C27 C28 C29 C30			CK45B1H471K CK45B1H821K CK45B1H471K CK45B1H182K CK45B1H102K	CERAMIC 470PF K CERAMIC 820PF K CERAMIC 470PF K CERAMIC 1800PF K CERAMIC 1000PF K		
C31 C32 C33 C34 C35	    -37		CK45B1H681K CK45B1H471K CE04EW1H010M C91-0117-05 CQ92M1H333K	CERAMIC 680PF K CERAMIC 470PF K ELECTRO 1.0UF 50WV CERAMIC 0.01UF K MYLAR 0.033UF K		
C38 C39 C40 C42 C43		*	C91-1081-05 C91-1082-05 C91-1081-05 CE04EW1H010M CK45F1H473Z	FIXED CAPACITOR (510PF, 50WV) FIXED CAPACITOR (560PF, 50WV) FIXED CAPACITOR (510PF, 50WV) ELECTRO 1.0UF 50WV CERAMIC 0.047UF Z		
C44 C45 C46 C47 C49		*	CK45B1H471K C91-1080-05 C91-1079-05 C91-1054-05 CE04EW1H010M	CERAMIC 470PF K FIXED CAPACITOR (390PF, 50WV) FIXED CAPACITOR (360PF, 50WV) FIXED CAPACITOR (330PF, 50WV) ELECTRO 1.0UF 50WV		
C50 C51 C52 C53 C54			CK45F1H473Z CK45B1H471K CC45RH1H201J CC45RH1H301J CC45RH1H201J	CERAMIC 0.047UF Z CERAMIC 470PF K CERAMIC 200PF J CERAMIC 300PF J CERAMIC 200PF J		
C56 C57 C58 C59 C60			CE04EW1H010M CK45F1H473Z CK45B1H471K CC45RH1H301J CC45RH1H161J	ELECTRO 1.0UF 50WV CERAMIC 0.047UF Z CERAMIC 470PF K CERAMIC 300PF J CERAMIC 160PF J		
C61 C63 C64 C65			CC45RH1H221J CE04EW1H010M CK45F1H473Z CK45B1H471K	CERAMIC 220PF J ELECTRO 1.0UF 50WV CERAMIC 0.047UF Z CERAMIC 470PF K		

# R-5000

## PARTS LIST

× New Parts

Parts without Parts No. are not supplied.

Les articles non mentionnés dans le Parts No. ne sont pas fournis.

Telle ohne Parts No. werden nicht geliefert.

Ref. No. 参照番号	Address 位置	New Parts 新	Parts No. 部品番号	Description 部品名 / 規格	Desti- nation 仕 向	Re- marks 備考
C66			CC45RH1H161J	CERAMIC 160PF J		
C67			CC45RH1H101J	CERAMIC 100PF J		
C68			CC45RH1H161J	CERAMIC 160PF J		
C70			CE04EW1H010M	ELECTRO 1.0UF 50WV		
C71			CK45F1H223Z	CERAMIC 0.022UF Z		
C72			CK45B1H471K	CERAMIC 470PF K		
C73			CC45RH1H161J	CERAMIC 160PF J		
C74			CC45RH1H620J	CERAMIC 62PF J		
C75			CC45RH1H101J	CERAMIC 100PF J		
C77			CE04EW1H010M	ELECTRO 1.0UF 50WV		
C78			CK45F1H223Z	CERAMIC 0.022UF Z		
C79			CK45B1H471K	CERAMIC 470PF K		
C80			CC45RH1H820J	CERAMIC 82PF J		
C81			CC45RH1H560J	CERAMIC 56PF J		
C82			CC45RH1H390J	CERAMIC 39PF J		
C84			CE04EW1H010M	ELECTRO 1.0UF 50WV		
C86			CK45B1H471K	CERAMIC 470PF K		
C87			CC45RH1H680J	CERAMIC 68PF J		
C88			CC45RH1H470J	CERAMIC 47PF J		
C89			CC45RH1H220J	CERAMIC 22PF J		
C91			CE04EW1H010M	ELECTRO 1.0UF 50WV		
C93			CK45B1H471K	CERAMIC 470PF K		
C95			CE04EW1H010M	ELECTRO 1.0UF 50WV		
C96			CK45B1H182K	CERAMIC 1800PF K		
C97			C91-0117-05	CERAMIC 0.01UF K		
C98			CE04EW1H010M	ELECTRO 1.0UF 50WV		
C100			CE04EW1H010M	ELECTRO 1.0UF 50WV		
C101			C91-0117-05	CERAMIC 0.01UF K		
C102			CC45SL1H390J	CERAMIC 39PF J		
C103			CC45RH1H330J	CERAMIC 33PF J		
C104			CC45SL1H680J	CERAMIC 68PF J		
C105			CC45SL1H150J	CERAMIC 15PF J		
C106			CK45B1H102K	CERAMIC 1000PF K		
C107			CE04EW1H010M	ELECTRO 1.0UF 50WV		
C108			C91-1008-05	CERAMIC 0.022UF K		
C109			CK45B1H471K	CERAMIC 470PF K		
C111			CC45SL1H050C	CERAMIC 5.0PF C		
C112, 113			C91-0119-05	CERAMIC 0.047UF K		
C114, 115			CC45RH1H120J	CERAMIC 12PF J		
C116			C91-0117-05	CERAMIC 0.01UF K		
C117			CK45B1H471K	CERAMIC 470PF K		
C120, 121			C91-0667-05	CERAMIC 0.0047UF K		
C122, 123			CC45RH1H150J	CERAMIC 15PF J		
C124			CK45B1H471K	CERAMIC 470PF K		
C125			C91-0667-05	CERAMIC 0.0047UF K		
C126			CK45B1H222K	CERAMIC 2200PF K		
C127			C91-0667-05	CERAMIC 0.0047UF K		
C130			CE04EW1H2R2M	ELECTRO 2.2UF 50WV		
C131			C91-0119-05	CERAMIC 0.047UF K		
C132			C91-0117-05	CERAMIC 0.01UF K		
C133			CE04EW1H4R7M	ELECTRO 4.7UF 50WV		
C134			CC45UJ1H270J	CERAMIC 27PF J		
C135			CC45RH1H220J	CERAMIC 22PF J		
C136			CC45RH1H100D	CERAMIC 10PF D		
C137			CC45RH1H120J	CERAMIC 12PF J		

## PARTS LIST

× New Parts  
 Parts without Parts No. are not supplied.  
 Les articles non mentionnés dans le Parts No. ne sont pas fournis.  
 Teile ohne Parts No. werden nicht geliefert.

Ref. No. 参照番号	Address 位置	New Parts 新	Parts No. 部品番号	Description 部品名 / 規格	Desti- nation 仕 向	Re- marks 備考
C138			CE04EW1A471M	ELECTRO 470UF 10WV		
C139			C91-0119-05	CERAMIC 0.047UF K		
C140			CK45B1H102K	CERAMIC 1000PF K		
C141			CC45RH1H080D	CERAMIC 8.0PF D		
C142			CK45B1H222K	CERAMIC 2200PF K		
C143			CC45UJ1H220J	CERAMIC 22PF J		
C144			CC45RH1H220J	CERAMIC 22PF J		
C145,146			CC45RH1H100D	CERAMIC 10PF D		
C147			CK45B1H102K	CERAMIC 1000PF K		
C148			CC45RH1H080D	CERAMIC 8.0PF D		
C149			CK45B1H222K	CERAMIC 2200PF K		
C150			CC45UJ1H180J	CERAMIC 18PF J		
C151			CC45RH1H220J	CERAMIC 22PF J		
C152,153			CC45RH1H100D	CERAMIC 10PF D		
C154			CK45B1H102K	CERAMIC 1000PF K		
C155			CC45RH1H080D	CERAMIC 8.0PF D		
C156			CK45B1H222K	CERAMIC 2200PF K		
C157			C91-0119-05	CERAMIC 0.047UF K		
C158			CC45UJ1H270J	CERAMIC 27PF J		
C159			CC45RH1H270J	CERAMIC 27PF J		
C160			CC45RH1H100D	CERAMIC 10PF D		
C161			CC45RH1H050C	CERAMIC 5.0PF C		
C162			CK45B1H102K	CERAMIC 1000PF K		
C163			CC45RH1H080D	CERAMIC 8.0PF D		
C164			CK45B1H182K	CERAMIC 1800PF K		
C165			CC45RH1H030C	CERAMIC 3.0PF C		
C166			CK45B1H471K	CERAMIC 470PF K		
C167			C91-0667-05	CERAMIC 0.0047UF K		
C168			CC45CH1H100D	CERAMIC 10PF D		
C169			CC45CH1H080D	CERAMIC 8.0PF D		
C170			CC45CH1H180J	CERAMIC 18PF J		
C171			CC45CH1H050C	CERAMIC 5.0PF C		
C172			CC45CH1H180J	CERAMIC 18PF J		
C173			CC45CH1H070D	CERAMIC 7.0PF D		
C174			CK45B1H222K	CERAMIC 2200PF K		
C175			C91-0667-05	CERAMIC 0.0047UF K		
C176			CK45B1H471K	CERAMIC 470PF K		
C178			CC45CH1H100D	CERAMIC 10PF D		
C179			CK45B1H222K	CERAMIC 2200PF K		
C180,181			CK45B1H182K	CERAMIC 1800PF K		
C182			CK45B1H471K	CERAMIC 470PF K		
C183			C91-0667-05	CERAMIC 0.0047UF K		
C184			CK45B1H222K	CERAMIC 2200PF K		
C185			CK45B1H182K	CERAMIC 1800PF K		
C186			C91-0769-05	CERAMIC 0.01UF M		
C190,191			CE04EW1H010M	ELECTRO 1.0UF 50WV		
C192,193			CK45B1H102K	CERAMIC 1000PF K		
C194			CC45CH1H390J	CERAMIC 39PF J		
C195			CC45CH1H220J	CERAMIC 22PF J		
C197			C91-0119-05	CERAMIC 0.047UF K		
C198			CC45CH1H050C	CERAMIC 5.0PF C		
-			E04-0157-05	RF COAXIAL CABLE RECEPTACLE(1P		
-			E23-0512-05	TERMINAL (MKR)		
CN1			E40-3239-05	PIN CONNECTOR (4P)		

# R-5000

## PARTS LIST

× New Parts

Parts without Parts No. are not supplied.

Les articles non mentionnés dans le Parts No. ne sont pas fournis.

Teile ohne Parts No. werden nicht geliefert.

Ref. No. 参照番号	Address 位置	New Parts 新	Parts No. 部品番号	Description 部品名 / 規格	Desti- nation 仕向	Re- marks 備考
CN2			E40-3237-05	PIN CONNECTOR (2P)		
CN3			E40-3238-05	PIN CONNECTOR (3P)		
CN4			E40-3240-05	PIN CONNECTOR (5P)		
CN5			E40-3241-05	PIN CONNECTOR (6P)		
CN6			E40-3237-05	PIN CONNECTOR (2P)		
CN7			E40-3239-05	PIN CONNECTOR (4P)		
CN8			E40-3237-05	PIN CONNECTOR (2P)		
TP1			E40-0211-05	PIN CONNECTOR (2P)		
-			F11-0793-14	SHIELDING COVER		
-			F11-0892-04	SHIELDING COVER		
L1			L40-1511-13	SMALL FIXED INDUCTOR(150UH)		
L2	,3		L34-1124-05	COIL		
L4			L34-0691-05	COIL		
L5			L40-1021-13	SMALL FIXED INDUCTOR(1MH)		
L6			L40-1001-13	SMALL FIXED INDUCTOR(10UH)		
L7			L40-1801-14	SMALL FIXED INDUCTOR(18UH)		
L8			L40-1201-14	SMALL FIXED INDUCTOR(12UH)		
L9			L40-8291-14	SMALL FIXED INDUCTOR(8.2UH)		
L10			L40-3991-14	SMALL FIXED INDUCTOR(3.9UH)		
L11			L40-5691-14	SMALL FIXED INDUCTOR(5.6UH)		
L12			L40-3982-14	SMALL FIXED INDUCTOR(0.39UH)		
L13			L40-1092-14	SMALL FIXED INDUCTOR(1UH)		
L14			L40-2292-14	SMALL FIXED INDUCTOR(2.2UH)		
L15		*	L34-4008-05	COIL		
L16			L40-1005-25	SMALL FIXED INDUCTOR(10UH)		
L17		*	L34-4008-05	COIL		
L18		*	L34-4010-05	COIL		
L19			L40-8295-25	SMALL FIXED INDUCTOR(8.2UH)		
L20		*	L34-4010-05	COIL		
L21		*	L34-4009-05	COIL		
L22			L40-4795-25	SMALL FIXED INDUCTOR(4.7UH)		
L23		*	L34-4009-05	COIL		
L24		*	L34-4005-05	COIL		
L25			L40-3995-25	SMALL FIXED INDUCTOR(3.9UH)		
L26		*	L34-4005-05	COIL		
L27		*	L34-4006-05	COIL		
L28			L40-3395-25	SMALL FIXED INDUCTOR(3.3UH)		
L29		*	L34-4006-05	COIL		
L30		*	L34-4007-05	COIL		
L31			L40-2795-25	SMALL FIXED INDUCTOR(2.7UH)		
L32		*	L34-4007-05	COIL		
L33		*	L34-4004-15	COIL		
L34			L40-1595-25	SMALL FIXED INDUCTOR(1.5UH)		
L35		*	L34-4004-15	COIL		
L36		*	L34-4002-05	COIL		
L37			L34-2245-05	COIL		
L38		*	L34-4002-05	COIL		
L39			L40-1021-13	SMALL FIXED INDUCTOR(1MH)		
L40			L40-1001-13	SMALL FIXED INDUCTOR(10UH)		
L41			L40-6891-13	SMALL FIXED INDUCTOR(6.8UH)		
L42			L40-1021-13	SMALL FIXED INDUCTOR(1MH)		
L43			L40-1021-12	SMALL FIXED INDUCTOR(1MH)		
L44			L34-2161-15	COIL		
L45			L34-0691-05	COIL		

## PARTS LIST

\* New Parts

Parts without Parts No. are not supplied.

Les articles non mentionnés dans le Parts No. ne sont pas fournis.

Teile ohne Parts No. werden nicht geliefert.

Ref. No. 参照番号	Address 位置	New Parts 新	Parts No. 部品番号	Description 部品名 / 規格	Desti- nation 仕向	Re- marks 備考
L46			L40-1001-13	SMALL FIXED INDUCTOR(10UH)		
L47			L40-1001-14	SMALL FIXED INDUCTOR(10UH)		
L48		*	L34-4003-05	COIL		
L50		*	L34-4003-05	COIL		
L51 -54			L40-1001-13	SMALL FIXED INDUCTOR(10UH)		
L55			L40-4711-13	SMALL FIXED INDUCTOR(470UH)		
L56			L32-0652-05	OSCILLATING COIL		
L57			L40-2292-14	SMALL FIXED INDUCTOR(2.2UH)		
L58			L32-0653-05	OSCILLATING COIL		
L59			L40-2292-14	SMALL FIXED INDUCTOR(2.2UH)		
L60			L32-0653-05	OSCILLATING COIL		
L61			L40-2292-14	SMALL FIXED INDUCTOR(2.2UH)		
L62		*	L34-4000-05	OSCILLATING COIL		
L63			L40-2292-14	SMALL FIXED INDUCTOR(2.2UH)		
L64			L34-1124-05	COIL		
L65 ,66			L34-1182-05	COIL		
L67			L40-6882-14	SMALL FIXED INDUCTOR(0.68UH)		
L68 ,69			L40-1001-13	SMALL FIXED INDUCTOR(10UH)		
L70			L40-4701-13	SMALL FIXED INDUCTOR(47UH)		
L71 -74			L33-0605-05	CHOKE COIL		
L75 ,76			L40-3391-14	SMALL FIXED INDUCTOR(3.3UH)		
T1 ,2			L19-0324-05	BALUN TRANSFORMER		
T3 ,4			L19-0347-05	BALUN TRANSFORMER		
RB1			R90-0457-05	MULTI-COMP (4.7KX10)		
VR1			R12-1429-05	TRIMMING PNT. (500)		
W23			R92-0150-05	JUMPER REST 0 OHM		
W32			R92-0150-05	JUMPER REST 0 OHM		
RL1 -3			S51-1428-05	RELAY		
D1 -3			1S1555	DIODE		
D4 ,5			1S5133	DIODE		
D6 ,7			US1090	DIODE		
D8			MA858	DIODE		
D9			1S1007	DIODE		
D10			MA858	DIODE		
D11			1S1007	DIODE		
D12			MA858	DIODE		
D13			1S1007	DIODE		
D14			MA858	DIODE		
D15			1S1007	DIODE		
D16			MA858	DIODE		
D17			1S1007	DIODE		
D18			MA858	DIODE		
D19			1S1007	DIODE		
D20			MA858	DIODE		
D21			1S1007	DIODE		
D22			MA858	DIODE		
D23			1S1007	DIODE		
D24			MA858	DIODE		
D25			1S1007	DIODE		
D26			MA858	DIODE		
D27			1S1007	DIODE		
D28			MTZ7.5JA	ZENER DIODE		
D29			ITT310TE	VARI-CAP DIODE		

R-3000

# PARTS LIST

\* New Parts

Parts without Parts No. are not supplied.

Les articles non mentionnés dans le Parts No. ne sont pas fournis.

Teile ohne Parts No. werden nicht geliefert.

Ref. No. 参照番号	Address 位置	New Parts 新	Parts No. 部品番号	Description 部品名 / 規格	Desti- nation 仕向	Re- marks 備考
D30		*	1SS132	DIODE		
D31			ITT310TE	VARI-CAP DIODE		
D32		*	1SS132	DIODE		
D33			ITT310TE	VARI-CAP DIODE		
D34		*	1SS132	DIODE		
D35			ITT310TE	VARI-CAP DIODE		
D36		*	1SS132	DIODE		
D37			DAP401	DIODE		
D38			MC911	DIODE		
D39		*	DAP601	DIODE		
D40			MTZ5.1JA	ZENER DIODE		
D41			1SS133	DIODE		
IC1			SN74LS145N	IC(DUAL MONO MULTI)DECODER)		
Q1 -6			2SK125	FET		
Q7			2SB698(E,F)	TRANSISTOR		
Q8 -11			2SK192A(GR)*J	FET		
Q12			2SC1907	TRANSISTOR		
Q13			2SC2668(Y)	TRANSISTOR		
Q14			2SC1907	TRANSISTOR		
Q15			2SC2668(Y)	TRANSISTOR		
Q16			2SC2053	TRANSISTOR		
<b>IF UNIT (X48-3000-00)</b>						
C2			CC45RH1H070D	CERAMIC 7.0PF	D	
C3			CC45CH1H150J	CERAMIC 15PF	J	
C5			C91-0667-05	CERAMIC 0.0047UF	K	
C7			CC45RH1H050C	CERAMIC 5.0PF	C	
C9 .10			CC45CH1H270J	CERAMIC 27PF	J	
C11			CC45CH1H330J	CERAMIC 33PF	J	
C14			CC45CH1H050C	CERAMIC 5.0PF	C	
C16			CC45RH1H030C	CERAMIC 3.0PF	C	
C17			CC45CH1H050C	CERAMIC 0.5PF	C	
C22			CC45SL1H390J	CERAMIC 39PF	J	
C23			CC45SL1H221J	CERAMIC 220PF	J	
C25			CK45B1H222K	CERAMIC 2200PF	K	
C26			CC45SL1H221J	CERAMIC 220PF	J	
C30			CE04EW1H010M	ELECTRO 1.0UF	50WV	
C36			CE04EW1E470M	ELECTRO 47UF	25WV	
C37			CK45B1H222K	CERAMIC 2200PF	K	
C38			CK45B1H182K	CERAMIC 1800PF	K	
C39			CC45SL1H101J	CERAMIC 100PF	J	
C47			CE04EW1H010M	ELECTRO 1.0UF	50WV	
C48			CC45SL1H101J	CERAMIC 100PF	J	
C51			CK45B1H471K	CERAMIC 470PF	K	
C52			CC45RH1H201J	CERAMIC 200PF	J	
C53			CE04EW1H2R2M	ELECTRO 2.2UF	50WV	
C54			CE04EW1H100M	ELECTRO 10UF	50WV	
C55			CK45B1H471K	CERAMIC 470PF	K	
C56			CE04EW1H0R1M	ELECTRO 0.1UF	50WV	
C60			CK45B1H182K	CERAMIC 1800PF	K	
C75			CK45B1H182K	CERAMIC 1800PF	K	
C90			CC45SL1H221J	CERAMIC 220PF	J	
C93			CC45CH1H150J	CERAMIC 15PF	J	
C94			CC45SL1H560J	CERAMIC 56PF	J	
C96			CE04EW1A101M	ELECTRO 100UF	10WV	

## PARTS LIST

\* New Parts

Parts without Parts No. are not supplied.

Les articles non mentionnés dans le Parts No. ne sont pas fournis.

Teile ohne Parts No. werden nicht geliefert.

Ref. No. 参照番号	Address 位置	New Parts 新	Parts No. 部品番号	Description 部品名 / 規格	Desti- nation 仕 向	Re- marks 備考
C97			CK45B1H471K	CERAMIC 470PF K		
C98			CK45B1H221K	CERAMIC 220PF K		
C99			CQ92M1H183K	MYLAR 0.018UF K		
C100			CC45CH1H330J	CERAMIC 33PF J		
C101			CC45CH1H220J	CERAMIC 22PF J		
C103			CK45B1H222K	CERAMIC 2200PF K		
C107			CE04EW1A101M	ELECTRØ 100UF 10WV		
C108			CK45B1H471K	CERAMIC 470PF K		
C109			CQ92M1H183K	MYLAR 0.018UF K		
C110			CC45SL1H390J	CERAMIC 39PF J		
C111			CC45SL1H470J	CERAMIC 47PF J		
C112			CK45B1H221K	CERAMIC 220PF K		
C114			CE04EW1A101M	ELECTRØ 100UF 10WV		
C115			CC45SL1H101J	CERAMIC 100PF J		
C117			CE04EW1HR47M	ELECTRØ 0.47UF 50WV		
C118			CE04EW1H3R3M	ELECTRØ 3.3UF 50WV		
C119			CE04EW1H010M	ELECTRØ 1.0UF 50WV		
C120			CE04EW1H4R7M	ELECTRØ 4.7UF 50WV		
C121			CE04EW1H100M	ELECTRØ 10UF 50WV		
C122			CE04EW1H010M	ELECTRØ 1.0UF 50WV		
C123			CE04EW1C330M	ELECTRØ 33UF 16WV		
C125			CE04EW1H010M	ELECTRØ 1.0UF 50WV		
C127			CE04EW1E470M	ELECTRØ 47UF 25WV		
C128			CC45SL1H101J	CERAMIC 100PF J		
C130			CE04EW1H010M	ELECTRØ 1.0UF 50WV		
C136			CE04EW1H010M	ELECTRØ 1.0UF 50WV		
C139			CE04EW1H010M	ELECTRØ 1.0UF 50WV		
C143			CK45B1H122K	CERAMIC 1200PF K		
C144			CQ92M1H332K	MYLAR 3300PF K		
C145			CK45B1H391K	CERAMIC 390PF K		
C150			CE04EW1E470M	ELECTRØ 47UF 25WV		
C152			CC45SL1H121J	CERAMIC 120PF J		
C153			CQ92M1H333K	MYLAR 0.033UF K		
C155			CE04EW1H3R3M	ELECTRØ 3.3UF 50WV		
C157, 158			CE04EW1E470M	ELECTRØ 47UF 25WV		
C160, 161			CE04EW1H2R2M	ELECTRØ 2.2UF 50WV		
C162			CE04EW1H100M	ELECTRØ 10UF 50WV		
C163, 164			CQ92M1H154K	MYLAR 0.15UF K		
C165			CQ92M1H123K	MYLAR 0.012UF K		
C166			CQ92M1H183K	MYLAR 0.018UF K		
C167			CE04EW1A101M	ELECTRØ 100UF 10WV		
C168			CQ92M1H333K	MYLAR 0.033UF K		
C169			CE04EW1E470M	ELECTRØ 47UF 25WV		
C170			CQ92M1H683K	MYLAR 0.068UF K		
C171			CE04EW1H220M	ELECTRØ 22UF 50WV		
C172			CE04EW1H010M	ELECTRØ 1.0UF 50WV		
C173			CE04EW1E101M	ELECTRØ 100UF 25WV		
C174			CE04EW1H220M	ELECTRØ 22UF 50WV		
C175			CQ92M1H104K	MYLAR 0.10UF K		
C176			CE04EW1E470M	ELECTRØ 47UF 25WV		
C177			CE04EW1H220M	ELECTRØ 22UF 50WV		
C178			CQ92M1H332K	MYLAR 3300PF K		
C179			CE04EW1E471M	ELECTRØ 470UF 25WV		
C183, 184			CE04EW1E102M	ELECTRØ 1000UF 25WV		
C186			CE04EW1H010M	ELECTRØ 1.0UF 50WV		

# R-5000

## PARTS LIST

× New Parts

Parts without Parts No. are not supplied.

Les articles non mentionnés dans le Parts No. ne sont pas fournis.

Teile ohne Parts No. werden nicht geliefert.

Ref. No. 参照番号	Address 位置	New Parts 新	Parts No. 部品番号	Description 部品名 / 規格	Desti- nation 仕 向	Re- marks 備考
C188			CE04EW1E470M	ELECTRO 47UF 25WV		
C191			CE04EW1HOR1M	ELECTRO 0.1UF 50WV		
C192			CC4SSL1H470J	CERAMIC 47PF J		
-			ED4-0154-05	RF COAXIAL CABLE RECEPTACLE		
-			E11-0414-05	PHONE JACK		
-			E23-0512-05	TERMINAL		
-			E29-0434-05	INTERCONNECTOR		
-			E31-2170-15	CONNECTING WIRE		
-			E33-1761-00	FINISHED WIRE SET		
-			E40-0517-05	PIN CONNECTOR		
-			E40-5059-05	PIN CONNECTOR		
CN1			E40-3241-05	PIN CONNECTOR (6P)		
CN2			E40-5066-05	PIN CONNECTOR (9P)		
CN3			E40-3238-05	PIN CONNECTOR (3P)		
CN4			E40-3237-05	PIN CONNECTOR (2P)		
CN6			E40-3239-05	PIN CONNECTOR (4P)		
CN7			E40-3243-05	PIN CONNECTOR (8P)		
CN8 ,9			E40-3240-05	PIN CONNECTOR (5P)		
CN10,11			E40-3238-05	PIN CONNECTOR (3P)		
CN12			E40-3240-05	PIN CONNECTOR (5P)		
CN13			E40-3237-05	PIN CONNECTOR (2P)		
TP1			E40-0211-05	PIN CONNECTOR		
-		*	F02-0430-14	HEAT SINK		
-			F11-0817-04	SHIELDING COVER		
-			F11-0818-24	SHIELDING COVER(COVER)		
-			J32-0761-04	BOSS		
CF1			L72-0315-05	CERAMIC FILTER (CFW455F)		
L1			L34-4003-05	COIL (58.1MHZ)		
L2			L32-0678-05	OSCILLATING COIL(58.1MHZ)		
L3			L34-4003-05	COIL (58.1MHZ)		
L4			L34-2074-05	COIL		
L5 ,6		*	L33-0693-05	CHOKE COIL (0.68UH)		
L7 ,8			L34-2116-15	COIL		
L9			L30-0509-05	IFT (8.83MHZ)		
L10			L34-0781-05	COIL		
L11			L34-2124-05	COIL		
L12			L40-2211-14	SMALL FIXED INDUCTOR(220UH)		
L13 ,14			L30-0503-05	IFT (455KHZ)		
L15 ,16			L34-0741-05	COIL		
L17 ,18			L40-2211-14	SMALL FIXED INDUCTOR(220UH)		
L19			L34-0678-05	COIL		
L20			L40-2211-15	SMALL FIXED INDUCTOR(220UH)		
L21			L34-0537-05	COIL		
L22			L34-0781-05	COIL		
L23			L40-1592-14	SMALL FIXED INDUCTOR(1.5UH)		
L24			L30-0519-05	IFT (455KHZ)		
L25			L30-0503-05	IFT (455KHZ)		
L26			L79-0446-05	COIL (DISCRI)		
L27 ,28			L40-1021-14	SMALL FIXED INDUCTOR(1MH)		
L29			L40-3391-13	SMALL FIXED INDUCTOR(3.3UH)		
L30			L40-1011-14	SMALL FIXED INDUCTOR(100UH)		
X1		*	L77-1319-05	CRYSTAL RESONATOR(49.2825MHZ)		
X2		*	L77-1320-05	CRYSTAL RESONATOR(8.375MHZ)		

## PARTS LIST

\* New Parts  
 Parts without Parts No. are not supplied.  
 Les articles non mentionnes dans le Parts No. ne sont pas fournis.  
 Teile ohne Parts No. werden nicht geliefert.

Ref. No. 参照番号	Address 位置	New Parts 新	Parts No. 部品番号	Description 部品名 / 規格	Desti- nation 仕向	Re- marks 備考
XF1 XF2 XF3		*	L71-0243-05 L71-0266-05 L71-0208-15	MCF (58.1125MHZ) MCF (8.83MHZ) MCF (YK-88S)		
- - - -			N09-0641-05 N30-3010-46 N35-3006-46 N35-3008-46	SCREW PAN HEAD MACHINE SCREW BINDING HEAD MACHINE SCREW BINDING HEAD MACHINE SCREW		
Δ R243 VR1 VR2 VR3 VR4		*	R92-0681-05 R12-1066-05 R12-3099-05 R12-1069-05 R12-1066-05	FIXED RESISTOR (1W, 4.7ΩHM) TRIMMING POT. (1K) TRIMMING POT. (47K) TRIMMING POT. (4.7K) TRIMMING POT. (1K)		
VR5 VR6 VR7 ,8 W64			R12-5046-05 R12-3098-05 R12-3096-05 R92-0150-05	TRIMMING POT. (100K) TRIMMING POT. (33K) TRIMMING POT. (10K) JUMPER REST 0 ΩHM		
D1 ,2 D3 D4 D5 -23 D24 -27			BA282 MC931 1S5133 1S1587 1N60	DIODE DIODE DIODE DIODE DIODE		
D28 D29 D30 D31 D32			MC931 1S5133 1S1587 MC911 MC931	DIODE DIODE DIODE DIODE DIODE		
D33 -36 D37 D38 -41 D42 ,43 D44 -48			1S5133 MC921 1S5133 MC921 1S5133	DIODE DIODE DIODE DIODE DIODE		
D49 D50 -55 D56 D57 -60 D61			1S1587 1S5133 MC921 1S5133 1S1587	DIODE DIODE DIODE DIODE DIODE		
D62 ,63 D64 D65 IC1 IC4			1S5133 1S5141VE 1S5133 NJM4558S NJM2903S	DIODE DIODE DIODE IC(OP AMP X2) IC(DUAL COMPALATOR)		
IC5 ,6 IC7 IC8 IC9 IC12			UPC577H NJM4558S NJM2903S TC4066BP NJM4558S	IC(OP AMP) IC(OP AMP X2) IC(DUAL COMPALATOR) CMOS IC(ANALOG SW X4) IC(OP AMP X2)		
Δ IC13 Δ IC14 IC15 Q1 Q2 ,3		*	MB3713 AN78ND9 TC4071BP 3SK73(Y) 2SC2668(Y)	IC(AF POWER AMP) IC(VOLTAGE REGULATOR/ +15V) IC(OP X4) X4) FET TRANSISTOR		
Q4 ,5 Q6 Q7			2SK125 DTC114ES DTC144WS	FET DIGITAL TRANSISTOR DIGITAL TRANSISTOR		

# R-5000

## PARTS LIST

× New Parts

Parts without Parts No. are not supplied.

Les articles non mentionnés dans le Parts No. ne sont pas fournis.

Teile ohne Parts No. werden nicht geliefert.

Ref. No. 参照番号	Address 位置	New Parts 新	Parts No. 部品番号	Description 部品名 / 規格	Desti- nation 仕 向	Re- marks 備考
Q8			2SC2668(Y)	TRANSISTOR		
Q9 -12			3SK73(Y)	FET		
Q13			2SC2787(L)	TRANSISTOR		
Q14 ,15			2SC2458(Y)	TRANSISTOR		
Q16			DTA124ES	DIGITAL TRANSISTOR		
Q17			DTC124ES	DIGITAL TRANSISTOR		
Q18			2SC2787(L)	TRANSISTOR		
Q19			3SK73(Y)	FET		
Q20			2SC2787(L)	TRANSISTOR		
Q21 ,22			3SK73(Y)	FET		
Q23 ,24			2SC2787(L)	TRANSISTOR		
Q25			2SC3113(B)	TRANSISTOR		
Q26 ,27			2SC2458(Y)	TRANSISTOR		
Q28			DTC144ES	DIGITAL TRANSISTOR		
Q29			2SC2458(Y)	TRANSISTOR		
Q30			2SK161(GR)	FET		
Q31			DTA144ES	DIGITAL TRANSISTOR		
Q32 ,33			2SC2459(BL)	TRANSISTOR		
Q34			DTA124ES	DIGITAL TRANSISTOR		
Q35			DTA144ES	DIGITAL TRANSISTOR		
Q36 -38			DTC144WS	DIGITAL TRANSISTOR		
Q39			2SC2458(Y)	TRANSISTOR		
Q40 -43			DTA114ES	DIGITAL TRANSISTOR		
Q44			DTA144ES	DIGITAL TRANSISTOR		
TH1 ,2			112-501-2	THERMISTOR (500)		
TH3			112-202-2	THERMISTOR (2K)		
IC2			X59-3010-00	COMPOSITE UNIT (AGC)		
IC3			X59-3020-00	COMPOSITE UNIT (S METER)		
IC10			X59-3030-00	COMPOSITE UNIT (NOTCH)		
IC11			X59-3040-00	COMPOSITE UNIT (SELECT)		
<b>PLL UNIT (X50-3030-00)</b>						
C1			CC45CH1H470J	CERAMIC 47PF	J	
C2			CC45CH1H101J	CERAMIC 100PF	J	
C4			CC45SL1H271J	CERAMIC 270PF	J	
C5			CK45B1H271K	CERAMIC 270PF	K	
C9			CC45SL1H220J	CERAMIC 22PF	J	
C13			CE04EW1A470M	ELECTRO 47UF	10WV	
C20			CO92M1H473K	MYLAR 0.047UF	K	
C21			CK45B1H182K	CERAMIC 1800PF	K	
C22			CE04EW1A470M	ELECTRO 47UF	10WV	
C23			C91-1008-05	CERAMIC 0.022UF	K	
C24			CC45UJ1H100D	CERAMIC 10PF	D	
C25			CC45UJ1H390J	CERAMIC 39PF	J	
C26			CC45UJ1H220J	CERAMIC 22PF	J	
C27			CC45CH1H040C	CERAMIC 4.0PF	C	
C28 -31			CK45B1H182K	CERAMIC 1800PF	K	
C32			CK45B1H222K	CERAMIC 2200PF	K	
C33			CK45B1H182K	CERAMIC 1800PF	K	
C34			CE04EW1A470M	ELECTRO 47UF	10WV	
C36			CK45B1H271K	CERAMIC 270PF	K	
C37			CC45UJ1H151J	CERAMIC 150PF	J	
C38			CK45B1H471K	CERAMIC 470PF	K	
C39			CC45SL1H680J	CERAMIC 68PF	J	
C41			CK45B1H271K	CERAMIC 270PF	K	

## PARTS LIST

× New Parts

Parts without Parts No. are not supplied.

Les articles non mentionnés dans le Parts No. ne sont pas fournis.

Teile ohne Parts No. werden nicht geliefert.

Ref. No.	Address	New Parts	Parts No.	Description	Destination	Remarks
参照番号	位置	新	部品番号	部品名 / 規格	仕向	備考
C43 -45			C91-1008-05	CERAMIC 0.022UF K		
C51			C91-1008-05	CERAMIC 0.022UF K		
C52			CC45SL1H101J	CERAMIC 100PF J		
C53			CC45CH1H050C	CERAMIC 5.0PF C		
C54			CC45SL1H101J	CERAMIC 100PF J		
C55			CK45B1H222K	CERAMIC 2200PF K		
C59 ,60			CK45B1H182K	CERAMIC 1800PF K		
C61			CC45CH1H1R5C	CERAMIC 1.5PF C		
C66			CK45B1H182K	CERAMIC 1800PF K		
C70			CS15E1HR33M	TANTAL 0.33UF 50WV		
C71			CK45B1H182K	CERAMIC 1800PF K		
C72 ,73			CC45UJ1H100D	CERAMIC 10PF D		
C74			CC45UJ1H390J	CERAMIC 39PF J		
C75			CK45B1H182K	CERAMIC 1800PF K		
C76			CE04EW1A101M	ELECTR0 100UF 10WV		
C77			CC45UJ1H100D	CERAMIC 10PF D		
C78			CC45CH1H030C	CERAMIC 3.0PF C		
C79			CC45CH1H080D	CERAMIC 8.0PF D		
C80			CC45CH1H030C	CERAMIC 3.0PF C		
C81 ,82			CK45B1H182K	CERAMIC 1800PF K		
C85 ,86			CK45B1H182K	CERAMIC 1800PF K		
C87			CK45B1H222K	CERAMIC 2200PF K		
C88 ,89			CK45B1H182K	CERAMIC 1800PF K		
C91			C91-1008-05	CERAMIC 0.022UF K		
C92			CK45B1H222K	CERAMIC 2200PF K		
C95			CC45CH1H060D	CERAMIC 6.0PF D		
C96			CC45CH1H100D	CERAMIC 10PF D		
C97			CC45CH1H270J	CERAMIC 27PF J		
C98			CC45CH1H060D	CERAMIC 6.0PF D		
C99			CC45CH1H270J	CERAMIC 27PF J		
C100			CC45CH1H040C	CERAMIC 4.0PF C		
C101			CC45CH1H050C	CERAMIC 5.0PF C		
C102,103			CK45B1H221K	CERAMIC 220PF K		
C104			CK45B1H182K	CERAMIC 1800PF K		
C107			C91-1008-05	CERAMIC 0.022UF K		
C108			CK45B1H182K	CERAMIC 1800PF K		
C109			C91-1008-05	CERAMIC 0.022UF K		
C112			CE04EW1A470M	ELECTR0 47UF 10WV		
C113			CK45B1H222K	CERAMIC 2200PF K		
C115			C91-1008-05	CERAMIC 0.022UF K		
C116			CE04EW1A470M	ELECTR0 47UF 10WV		
C120			CE04EW1A470M	ELECTR0 47UF 10WV		
C121			C91-1008-05	CERAMIC 0.022UF K		
C122,123		*	C91-1083-05	FIXED CAPACIT0R(0.4UF)		
C130			CO92M1H473K	MYLAR 0.047UF K		
C132			CE04EW1A470M	ELECTR0 47UF 10WV		
C133			CC45UJ1H050C	CERAMIC 5.0PF C		
C134			CC45UJ1H390J	CERAMIC 39PF J		
C135			C91-1008-05	CERAMIC 0.022UF K		
C138			CC45CH1H010C	CERAMIC 1.0PF C		
C139			CC45UJ1H270J	CERAMIC 27PF J		
C144			CE04EW1A470M	ELECTR0 47UF 10WV		
C145			CK45B1H821K	CERAMIC 820PF K		
C146			CK45B1H391K	CERAMIC 390PF K		
C147			CK45B1H152K	CERAMIC 1500PF K		

# R-5000

## PARTS LIST

× New Parts

Parts without Parts No. are not supplied.

Les articles non mentionnés dans le Parts No. ne sont pas fournis.

Teile ohne Parts No. werden nicht geliefert.

Ref. No. 参照番号	Address 位置	New Parts 新	Parts No. 部品番号	Description 部品名 / 規格	Desti- nation 仕 向	Re- marks 備考
C148			CC45SL1H151J	CERAMIC 150PF J		
C149			C91-1008-05	CERAMIC 0.022UF K		
C151			CK45B1H821K	CERAMIC 820PF K		
C152			C91-1008-05	CERAMIC 0.022UF K		
C154			C91-1008-05	CERAMIC 0.022UF K		
C157			CC45CH1H050C	CERAMIC 5.0PF C		
C158			C91-1008-05	CERAMIC 0.022UF K		
C160-163			C91-1008-05	CERAMIC 0.022UF K		
C164			CC45CH1H030C	CERAMIC 3.0PF C		
C165			CC45CH1H270J	CERAMIC 27PF J		
C166			CC45CH1H070D	CERAMIC 7.0PF D		
C167			CC45CH1H150J	CERAMIC 15PF J		
C169			CC45SL1H150J	CERAMIC 15PF J		
C170			C91-1008-05	CERAMIC 0.022UF K		
C172			CC45CH1H180J	CERAMIC 18PF J		
C173			CK45B1H222K	CERAMIC 2200PF K		
C174, 175			CK45B1H182K	CERAMIC 1800PF K		
C177			CK45B1H222K	CERAMIC 2200PF K		
C178			CC45CH1H150J	CERAMIC 15PF J		
C179			CC45CH1H100D	CERAMIC 10PF D		
C180			CC45CH1H150J	CERAMIC 15PF J		
C181			CK45B1H182K	CERAMIC 1800PF K		
C182			CC45CH1H030C	CERAMIC 3.0PF C		
C183			CC45CH1H150J	CERAMIC 15PF J		
C184			CE04EW1A470M	ELECTRO 47UF 10WV		
C186			CE04EW1H010M	ELECTRO 1.0UF 50WV		
C188			C91-1008-05	CERAMIC 0.022UF K		
C189			CE04EW1A470M	ELECTRO 47UF 10WV		
C192			C91-1008-05	CERAMIC 0.022UF K		
C205			CE04EW1A470M	ELECTRO 47UF 10WV		
C207-209			CC45CH1H220J	CERAMIC 22PF J		
C210, 211			CO92M1H102K	MYLAR 1000PF K		
C214			C91-1008-05	CERAMIC 0.022UF K		
TC1			CO5-0031-15	TRIMMING CAP (10PF)		
-			E29-0440-14	TERMINAL (GND)		
BF0			E04-0157-05	RF COAXIAL CABLE RECEPTACLE		
CN1, 2			E40-3237-05	PIN CONNECTOR (2P)		
CN3			E40-3240-05	PIN CONNECTOR (5P)		
CN4			E40-3239-05	PIN CONNECTOR (4P)		
CN6			E40-3243-05	PIN CONNECTOR (8P)		
HET			E04-0157-05	RF COAXIAL CABLE RECEPTACLE		
MKR			E23-0512-05	TERMINAL		
CF1			L72-0350-05	CERAMIC FILTER (9.285MHZ)		
CF2			L72-0351-05	CERAMIC FILTER (8.83MHZ)		
L3, 4			L40-1511-13	SMALL FIXED INDUCTOR(150UH)		
L5			L32-0666-15	OSCILLATING COIL		
L6			L40-1592-13	SMALL FIXED INDUCTOR(1.5UH)		
L7			L40-1021-13	SMALL FIXED INDUCTOR(1MH)		
L8, 9			L40-1811-25	SMALL FIXED INDUCTOR(180UH)		
L10, 11			L34-2026-05	COIL		
L12, 13			L34-2108-15	COIL		
L14			L34-1182-05	COIL		
L15			L40-1592-13	SMALL FIXED INDUCTOR(1.5UH)		
L16			L32-0676-05	OSCILLATING COIL		

## PARTS LIST

× New Parts

Parts without Parts No. are not supplied.

Les articles non mentionnés dans le Parts No. ne sont pas fournis.

Teile ohne Parts No. werden nicht geliefert.

Ref. No. 参照番号	Address 位置	New Parts 新	Parts No. 部品番号	Description 部品名 / 規格	Desti- nation 仕向	Re- marks 備考
L17			L40-2211-13	SMALL FIXED INDUCTOR(220UH)		
L18			L40-1511-13	SMALL FIXED INDUCTOR(150UH)		
L19 -21			L40-6882-14	SMALL FIXED INDUCTOR(0.68UH)		
L22			L40-4791-14	SMALL FIXED INDUCTOR(4.7UH)		
L23			L40-2211-12	SMALL FIXED INDUCTOR(220UH)		
L24			L40-6811-13	SMALL FIXED INDUCTOR(680UH)		
L25			L32-0675-05	OSCILLATING COIL		
L26			L40-1001-13	SMALL FIXED INDUCTOR(10UH)		
L27			L40-1021-13	SMALL FIXED INDUCTOR(1MH)		
L28 ,29			L40-5611-25	SMALL FIXED INDUCTOR(560UH)		
L30			L34-0781-05	COIL		
L31 ,32			L40-1001-14	SMALL FIXED INDUCTOR(10UH)		
L33			L34-1181-05	COIL		
L34			L40-3382-14	SMALL FIXED INDUCTOR(0.33UH)		
L36			L34-1181-05	COIL		
L37			L40-1011-14	SMALL FIXED INDUCTOR(100UH)		
X1			L77-1318-05	CRYSTAL RESONATOR(18MHZ)		
IB1			R90-0600-05	MULTI-COMP (100PFX4)		
IB2			R90-0584-05	MULTI-COMP (100PFX7)		
VR1			R12-4414-05	TRIMMING PNT. (50KB)		
D1			1SS133	DIODE		
D2 ,3			ITT310TE	VARI CAP DIODE		
D4			1SV153	VARI CAP		
D6			1SS133	DIODE		
D7			MTZ5.1JA	ZENER DIODE (5.1V)		
DB			1SS133	DIODE		
D9 ,10			1SV153	VARI CAP		
D11 -13			1S1587	DIODE		
D14 ,15			1SS133	DIODE		
D16 -19			BA282	DIODE		
IC1			SN74LS73AN	IC(DUAL JK-FF)		
IC2			MN6147C	IC(FREQ SYNTHESIZER PLL)		
IC3			M54459L	IC(PRE SCALER)		
IC4			SN74LS90N	IC(DECADE COUNRERS)		
IC5 -7			SN16913P	IC(DUBLE BALANCED MIXERS)		
IC8			MB87006	IC(FREQ SYNTHESIZER PLL)		
IC9			UPB551C	IC(PRE SCALER 1/20 OR 1/100)		
IC10			SN16913P	IC(DUBLE BALANCED MIXERS)		
IC11			SN74S74N	IC(DUAL D-FF)		
IC12			MB87006	IC(FREQ SYNTHESIZER PLL)		
IC13			BA718	IC(OP AMP X2)		
IC14			MN6147C	IC(FREQ SYNTHESIZER PLL)		
IC15			M54459L	IC(PRE SCALER)		
IC16			SN74LS90N	IC(DECADE COUNRERS)		
IC17			SN16913P	IC(DUBLE BALANCED MIXERS)		
IC18			AN78N05	IC(AVR) 5V		
△ IC19			AN78M09	IC(AVR) 9V		
Q1			2SC2668(Y)	TRANSISTOR		
Q2 ,3			2SC2787(L)	TRANSISTOR		
Q4 -7			2SC2668(Y)	TRANSISTOR		
Q8			2SC1907	TRANSISTOR		
Q9 ,12			2SC2668(Y)	TRANSISTOR		
Q13			2SC1907	TRANSISTOR		
Q14 -16			2SC2668(Y)	TRANSISTOR		

# R-5000

## PARTS LIST

\* New Parts

Parts without Parts No. are not supplied.

Les articles non mentionnés dans le Parts No. ne sont pas fournis.

Teile ohne Parts No. werden nicht geliefert.

Ref. No. 参照番号	Address 位置	New Parts 新	Parts No. 部品番号	Description 部品名 / 規格	Desti- nation 向	Re- marks 備考
Q17 -19 Q20 -22 Q23 Q24 Q25			2SC2787(L) 2SC2668(Y) DTA124ES DTC124ES DTC144WS	TRANSISTOR TRANSISTOR DIGITAL TRANSISTOR DIGITAL TRANSISTOR DIGITAL TRANSISTOR		
<b>CONTROL UNIT (X53-3020-XX) -11 : K,M,T,W1 -61 : W2 -71 : X</b>						
C1 ,2 C4 C7 C10 C11			CC45CH1H330J C90-0822-05 C90-0822-05 CE04CW1HR47M CE04CW1C470M	CERAMIC 33PF J ELECTRO 47UF 16WV ELECTRO 47UF 16WV ELECTRO 0.47UF 50WV ELECTRO 47UF 16WV		
C14 C15 ,16 C19 C22 C28			C90-0822-05 CC45SL1H101J CQ92M1H472K C90-0822-05 CQ92M1H103K	ELECTRO 47UF 16WV CERAMIC 100PF J MYLAR 4700PF K ELECTRO 47UF 16WV MYLAR 0.010UF K		
C39 -41 C51 C55 C57 C59		*	C91-0753-05 C90-2046-05 C90-0822-05 C90-0822-05 C90-0822-05	CERAMIC 470PF K ELECTRO 22UF 10WV ELECTRO 47UF 16WV ELECTRO 47UF 16WV ELECTRO 47UF 16WV		
C62 C73 C74 ,75 C76 ,77 C100-106		*	C90-0822-05 C90-2046-05 CC45CH1H220J CK45B1H471K C91-0753-05	ELECTRO 47UF 16WV ELECTRO 22UF 10WV CERAMIC 22PF J CERAMIC 470PF K CERAMIC 470PF K		
- - - - -			E02-0114-05 E02-2001-05 E23-0512-05 E31-3161-05 E31-3162-05	IC SOCKET (16P) IC SOCKET (28P) TERMINAL CONNECTING WIRE(A,13P) CONNECTING WIRE(B,12P)		
- CN1 CN2 CN4 CN5 ,6			E31-3163-05 E40-3238-05 E40-3239-05 E40-3240-05 E40-3241-05	CONNECTING WIRE(C,9P) PIN CONNECTOR (3P) PIN CONNECTOR (4P) PIN CONNECTOR (5P) PIN CONNECTOR (6P)		
CN10 CN11 CN12 CN13 CN14			E40-3240-05 E40-3243-05 E40-3242-05 E40-5066-05 E40-3243-05	PIN CONNECTOR (5P) PIN CONNECTOR (8P) PIN CONNECTOR (7P) PIN CONNECTOR (9P) PIN CONNECTOR (8P)		
CN15 CN16 CNS3 CNS4 ,55 CNS6			E40-3239-05 E40-3242-05 E40-3243-05 E40-3241-05 E40-3237-05	PIN CONNECTOR (4P) PIN CONNECTOR (7P) PIN CONNECTOR (8P) PIN CONNECTOR (6P) PIN CONNECTOR (2P)		
CNS7 CNS8 CNS9			E40-3240-05 E40-3241-05 E40-3237-05	PIN CONNECTOR (5P) PIN CONNECTOR (6P) PIN CONNECTOR (2P)		
-			J31-0503-05	COLLAR		
L1 L2 L4 L5			L40-1011-13 L40-1011-03 L40-1011-14 L40-1011-03	SMALL FIXED INDUCTOR SMALL FIXED INDUCTOR SMALL FIXED INDUCTOR SMALL FIXED INDUCTOR		

## PARTS LIST

× New Parts

Parts without Parts No. are not supplied.

Les articles non mentionnés dans le Parts No. ne sont pas fournis.

Telle ohne Parts No. werden nicht geliefert.

Ref. No. 参照番号	Address 位置	New Parts 新	Parts No. 部品番号	Description 部品名 / 規格	Desti- nation 仕 向	Re- marks 備考
L23 L50 ,51 L52 L53 -55 L57			L40-1011-14 L40-1011-14 L40-1011-13 L40-1011-03 L40-1011-14	SMALL FIXED INDUCTOR SMALL FIXED INDUCTOR SMALL FIXED INDUCTOR SMALL FIXED INDUCTOR SMALL FIXED INDUCTOR		
L58 ,59 X1 X50 X51			L40-4701-14 L78-0019-05 L78-0015-05 L77-1256-05	SMALL FIXED INDUCTOR RESONATOR (1.99MHZ) RESONATOR (2.45MHZ) CRYSTAL RESONATOR(32.768KHZ)		
RB1 RB50 RB51 RB52			R90-0510-05 R90-0510-05 R90-0521-05 R90-0597-05	MULTI-COMP (4.7KX8) MULTI-COMP (4.7KX8) MULTI-COMP (47KX7) MULTI-COMP (1KX4)		
D1 -9 D51 -54 D65 -72 D73 D74 -76			1SS133 1SS133 1SS133 1SS133 1SS133	DIODE DIODE DIODE DIODE DIODE	X1 W2	
D79 D85 ,86 IC1 IC2 IC3			1SS133 1SS133 * UFD7800G * MSM82C55AP-5 PST520D	DIODE DIODE IC(MICROPROCESSOR) IC(CMOS PROGRAMMABLE I/O) IC(LOW POWER RESET)		
IC4 IC5 IC6 IC7 IC50			TC4069UBP TC4011BP TC4030BP TC4011BP MB8418-20LP-GRA	IC(INVERTER X6) IC(NAND X4) IC(EXCLUSIVE OR X4) IC(NAND X4) IC(16K RAM)		
IC51 IC52 IC53 IC56 IC57			* SN74LS138N * MBM27128-25JB1 * MSM82C55AP-5 SN7404N * MSM6242RS	IC(DECODERS) IC(128K CMOS UV-EPR0M) IC(CMOS PROGRAMMABLE I/O) IC(6-CIRCUIT INVERTER) IC(REAL TIME CLOCK)		
Q1 -7 Q14 -17 Q50			* DTC143ES * DTC143ES DTC144WS	DIGITAL TRANSISTOR DIGITAL TRANSISTOR DIGITAL TRANSISTOR		
<b>DISPLAY UNIT (X54-3010-00)</b>						
C1 C3 C4 C5 -7 C11			C90-0871-05 C90-0504-05 CQ92M1H223K C90-0504-05 C90-0822-05	ELECTRO 220UF 16WV ELECTRO 10UF 35WV MYLAR 0.022UF K ELECTRO 10UF 35WV ELECTRO 47UF 16WV		
C15			C90-0822-05	ELECTRO 47UF 16WV		
CN1 CN2 CN3 CN4 CN5			E40-3243-05 E40-3242-05 E40-3240-05 E40-3238-05 E40-3240-05	PIN CONNECTOR (8P) PIN CONNECTOR (7P) PIN CONNECTOR (5P) PIN CONNECTOR (3P) PIN CONNECTOR (5P)		
CN56			E40-3242-05	PIN CONNECTOR (7P)		
L1 ,2 L3 L4 T1			L40-1011-13 L40-1011-14 L40-1011-13 L19-0323-05	SMALL FIXED INDUCTOR(100UH) SMALL FIXED INDUCTOR(100UH) SMALL FIXED INDUCTOR(100UH) BALUN TRANSFORMER		

**R-5000**

# PARTS LIST

× New Parts

Parts without Parts No. are not supplied.

Les articles non mentionnés dans le Parts No. ne sont pas fournis.

Telle ohne Parts No. werden nicht geliefert.

Ref. No. 参照番号	Address 位置	New Parts 新	Parts No. 部品番号	Description 部品名 / 規格	Desti- nation 仕 向	Re- marks 備考
RB1 RB2 RB3 W50 -53			R90-0511-05 R90-0193-05 R90-0520-05 R92-1061-05	MULTI-COMP (47KX8) MULTI-COMP 47KX9 J 1/6W MULTI-COMP (47KX5) JUMPER REST 0 OHM		
S7 -60			S40-2440-15	PUSH SWITCH		
D1 -4 D5 D6 FIP1 IC1			1S1555 MTZ5.1JA MTZ3.9JB FIP13BM7 UPD6300C	DIODE ZENER DIODE ZENER DIODE DISPLAY TUBE IC (FL LATCH DRIVER)		
IC2 IC3 Q1 ,2 Q3 Q4 ,5			MB4052 TC4013BP DTA114ES DTC144WS 2SC1959(Y)	IC (4CH 8BIT A/D CONVERTER (ADC)) IC (D FLIP-FLIP X2) DIGITAL TRANSISTOR DIGITAL TRANSISTOR TRANSISTOR		
<b>AGC (X59-3010-00)</b>						
--			E23-0471-05	TERMINAL		
R1 -4 R5 W1 W2 ,3			RK73FB2A223J RK73EB2B224J R92-0670-05 R92-0679-05	CHIP R 22K J 1/10W CHIP R 220K J 1/8W CHIP R 0 OHM FIXED RESISTOR		
IC1 IC2		*	TC4001BF TC4066BF	IC (NOR X6) IC (BILATERAL SWITCH X4)H)		
<b>S METER (X59-3020-00)</b>						
--			E23-0471-05	TERMINAL		
R1 R2 R3 R4 R5			RK73FB2A103J RK73FB2A101J RK73FB2A222J RK73FB2A223J RK73FB2A103J	CHIP R 10K J 1/10W CHIP R 100 J 1/10W CHIP R 2.2K J 1/10W CHIP R 22K J 1/10W CHIP R 10K J 1/10W		
R6 R7 R8 R9 R10			RK73FB2A152J RK73FB2A332J RK73FB2A682J RK73FB2A562J RK73FB2A103J	CHIP R 1.5K J 1/10W CHIP R 3.3K J 1/10W CHIP R 6.8K J 1/10W CHIP R 5.6K J 1/10W CHIP R 10K J 1/10W		
W1 -3			R92-0670-05	CHIP R 0 OHM		
D1 ,2 Q1 Q2 ,3 Q4 Q5			DAN202(K) 2SC2712(Y) 2SA1162(Y) 2SC2712(Y) 2SK211(GR)	CHIP DIODE CHIP TRANSISTOR CHIP TRANSISTOR CHIP TRANSISTOR CHIP FET		
<b>NOTCH (X59-3030-00)</b>						
C1 ,2 C3			CK73FB1H682K CK73FB1H271K	CHIP C 6800PF K CHIP C 270PF K		
--			E23-0471-05	TERMINAL		
R1 -4 R5 R6 R7 R8			RK73FB2A913J RK73FB2A681J RK73FB2A913J RK73FB2A471J RK73FB2A913J	CHIP R 91K J 1/10W CHIP R 680 J 1/10W CHIP R 91K J 1/10W CHIP R 470 J 1/10W CHIP R 91K J 1/10W		

# PARTS LIST

\* New Parts

Parts without Parts No. are not supplied.

Les articles non mentionnes dans le Parts No. ne sont pas fournis.

Teile ohne Parts No. werden nicht geliefert.

Ref. No. 参照番号	Address 位置	New Parts 新	Parts No. 部品番号	Description 部品名 / 規格	Desti- nation 仕向	Re- marks 備考
R9			RK73FB2A102J	CHIP R 1.0K J 1/10W		
R10			RK73FB2A913J	CHIP R 91K J 1/10W		
R12			RK73FB2A102J	CHIP R 1.0K J 1/10W		
R13			RK73FB2A6B4J	CHIP R 680K J 1/10W		
W1			R92-0670-05	CHIP R 0 OHM		
IC1			NJM4558M	IC(OP AMP X2)		
<b>SELECT (X59-3040-00)</b>						
-			E23-0471-05	TERMINAL		
R1			RK73FB2A223J	CHIP R 22K J 1/10W		
R2			RK73FB2A472J	CHIP R 4.7K J 1/10W		
R3 -5			RK73FB2A474J	CHIP R 470K J 1/10W		
W1			R92-0670-05	CHIP R 0 OHM		
W2 -5			R92-0679-05	FIXED RESISTOR		
D1			DAN202(K)	CHIP DIODE		
IC1			TC4066BF	IC(BILATERAL SWITCH X4)H)		
Q1			DTA124EK	DIGITAL TRANSISTOR		
Q2 .3			DTC144WK	DIGITAL TRANSISTOR		



## DISASSEMBLY

- : N09-0256-05
- : N35-3006-41
- : N09-2013-05
- : N32-3004-46
- : N35-2605-41
- : N35-3006-45
- : N35-3006-46
- : N87-2606-41
- : N87-3016-46
- : N35-2606-41

- A GND
- C M3x6 (B1)NI
- D M3x4 (F)
- G M2.6x5 (B1)NI
- L M3x6 (B1)BLK
- M #2.6x6 (Br-Tap)
- N #3x6 (Br-Tap)Ni
- R M2.6x6 (B1)NI

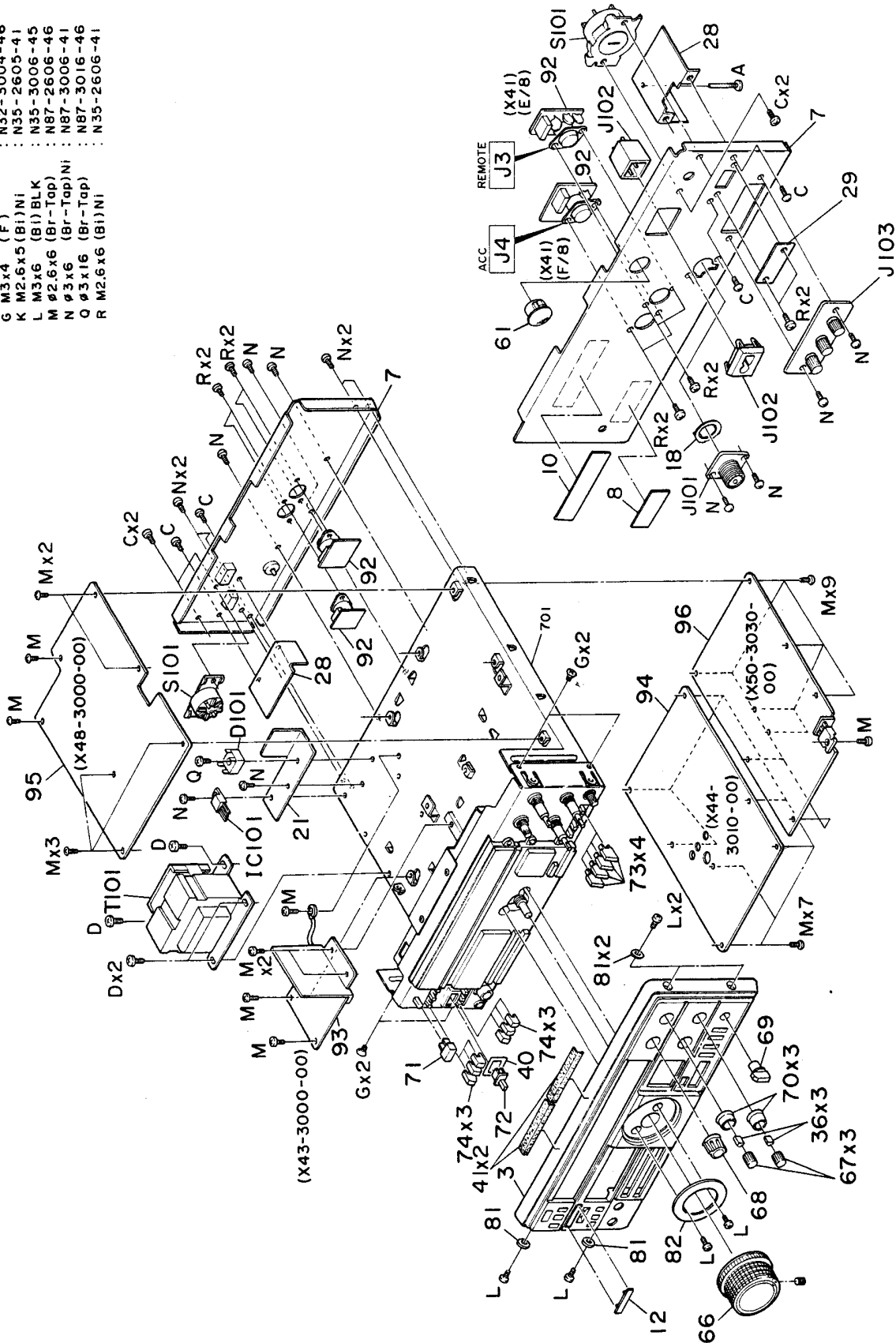

E

D

C



DISASSEMBLY

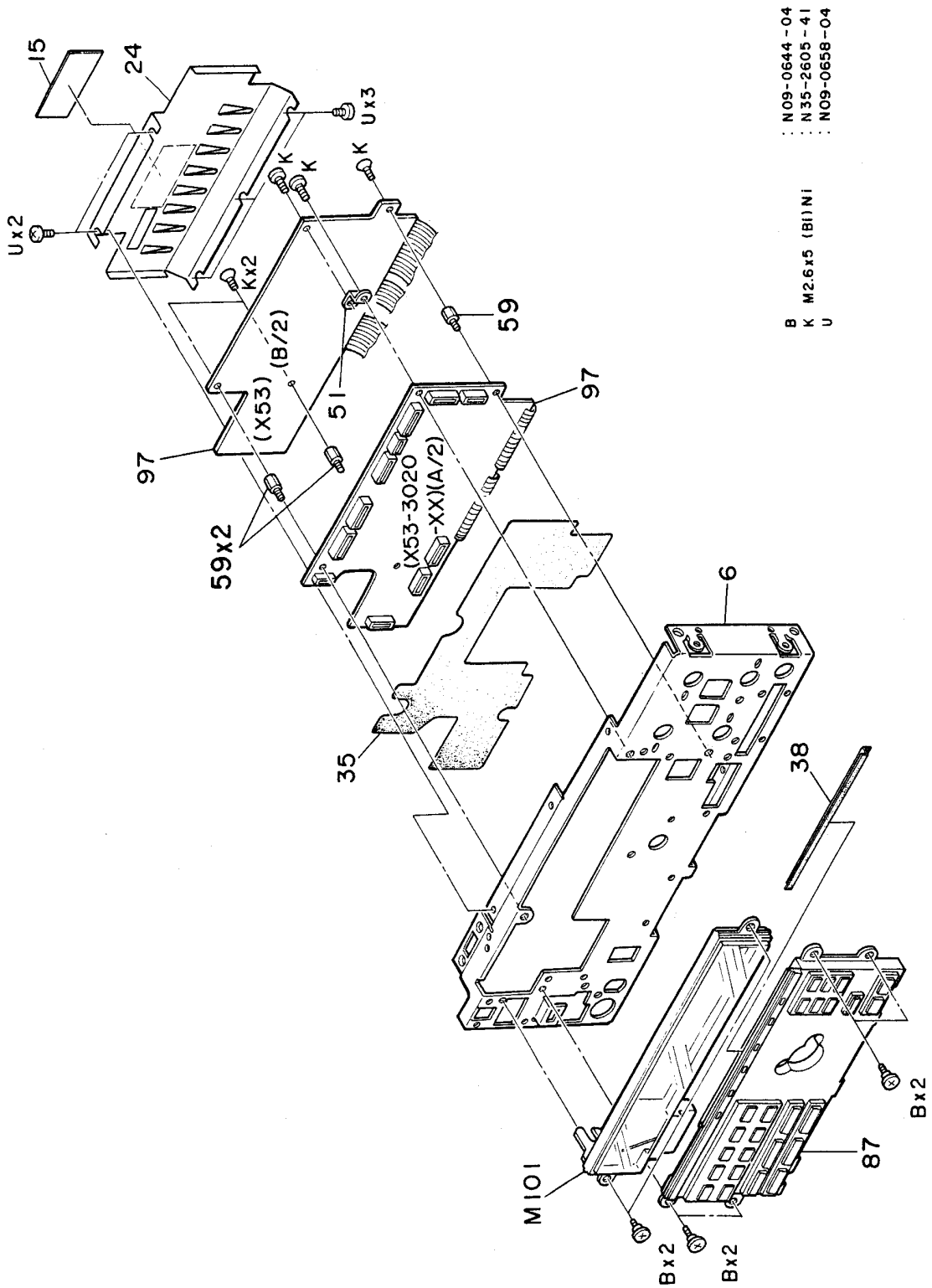

# PACKING

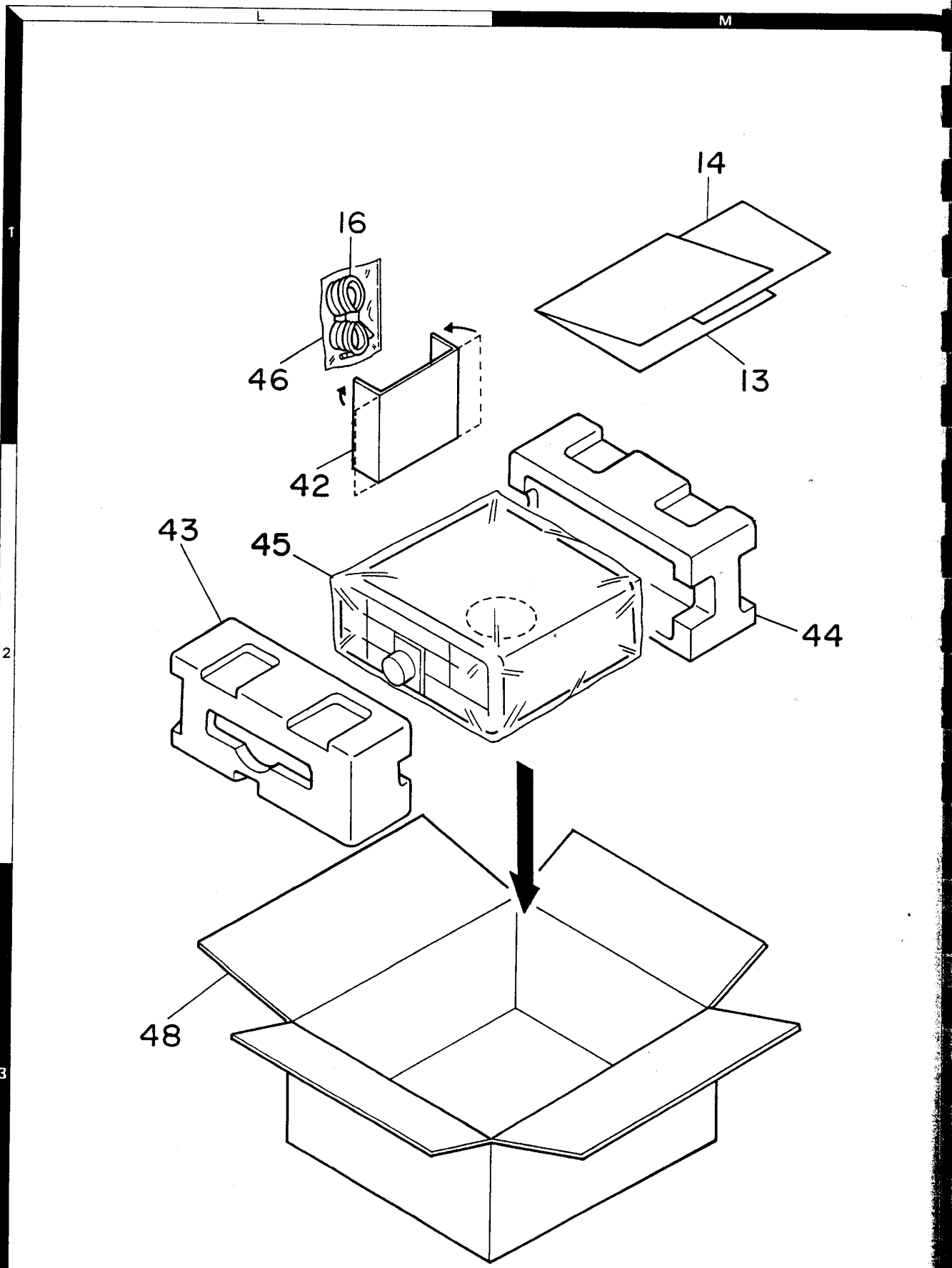



# ADJUSTMENT

## PLL ADJUSTMENT

Item	Condition	Measurement			Adjustment			Specification/Remarks
		Test equipment	Unit	Terminal	Unit	Part	Method	
1. Reference FREQ.		f. counter	PLL	IC1 ⑤	PLL	TC1	18.000.00MHz	±10Hz
		RF V.M					Check	300~350mV
2. PLL1	1) FREQ. : 14.999.99 MODE : FSK	DC V.M	PLL	TP1	PLL	L5	1.5V	1.4~1.6V
	2) FREQ. : 15.000.00 MODE : CW						Check	3.7~4.3V
		RF V.M		IC2 ⑥			Check	70~100mV
3. PLL2	1) FREQ. : 15.000.00 MODE : FM	DC V.M	PLL	TP2	PLL	L16	2.0V	1.9~2.1V
	2) FREQ. : 14.999.99 MODE : FM						Check	3.0~3.6V
		RF V.M		IC7 ⑤			Check	25~45mV
4. PLL3	1) FREQ. : 15.000.00 MODE : FM	f.counter	PLL	TP3	PLL	TC1	23.000.00MHz	±10Hz
		RF V.M					Check	40~120mV
5. PLL4	1) FREQ. : 15.000.00 MODE : FM	DC V.M	PLL	TP4	PLL	L25	25V	2.4~2.6V
	2) FREQ. : 15.000.00 MODE : USB IF SHIFT VR : Center						Check	2.8~3.0V
		RF V.M		IC5 ④			Check	60~90mV
6. BFO output		RF V.M	PLL	BFO	PLL	L30	MAX.	7mV (Ref.)
7. BPF 1		RF V.M	PLL	IC7 ②	PLL	L10, L11	MAX. then 2dB down. down with L10.	6mV (Ref.)
8. BPF 2	1) Connect the oscilloscope to TP5. Connect the Sweep Gen. to Q9 (base) thru the condensor.	SCOPE	PLL	TP5 GND	PLL	L12, L13	Adjust as shown below.	
		Sweep Gen.		Q9 Q9 (base) GND				

Q9  
0.1µF  
To Sweep generator

X : 1V/DIV  
Y : 10mV/DIV

## OTHER ADJUSTMENT

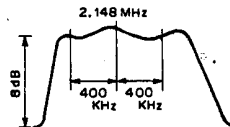
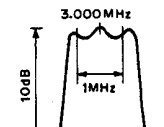
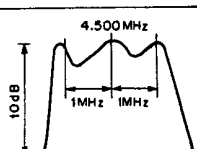
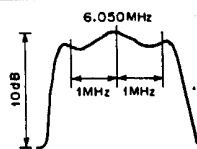
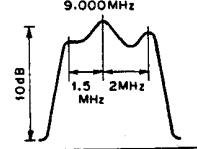
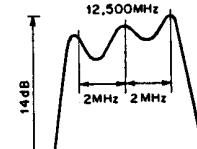

Item	Condition	Measurement			Adjustment			Specification/Remarks	
		Test equipment	Unit	Terminal	Unit	Part	Method		
1. Reset	1) Set the Power SW ON, while depressing the <b>A=B</b> key.	Display					Check	VFO A 15.000.00 MODE : AM ANT : ANT1 BUSY : lit on	
2. Voltage check (1)	1)  2) MODE : FM 3) MODE : FSK 4) MODE : AM 5) MODE : CW 6) MODE : USB	DC V.M	IF	⑦-8			14V	13.5~15.0V	
				⑦-4			-5V	4.5~5.5V	
				⑦-1			9V	8.5~9.5V	
				②-5			(FMG)	Less than 1.0V	
				②-4			(RYG)	Less than 1.0V	
				②-3			(AMG)	Less than 1.0V	
				②-2			(CWG)	Less than 1.0V	
3. RFG	1)	DC V.M	IF	TP3	IF	VR2	3.0V	2.9~3.1V	
4. Voltage check (2)	1)	DC V.M	PLL	W31			9V	8.5~9.5V	
				L23			5V	4.6~5.3V	
				RF	W42			8.9V	8.4~9.4V
							Depress the HF/VHF key once.	0V momentarily, then turns 8.9V again.	
				⑦-1			9V	8.5~9.5V	

## ADJUSTMENT

Item	Condition	Measurement			Adjustment			Specification/Remarks				
		Test equipment	Unit	Terminal	Unit	Part	Method					
5 IF Shift	1) IF SHIFT VR : Center	DC V.M	SW(B/8)	⑧ -4	SW(B/8)	VR6	1.1V	1.05~1.15V				
6 LOCAL	1) Disconnect the HET connector in the IF unit and connect the FREQ. counter.	f.counter	IF	L34			Check 49.2825MHz	±1.5kHz				
	2) Connect the HET connector after check.											
7 IFO	1) MODE : USB	f.counter	IF	R139 lead wire	SW(B/8)	VR7	8831.5kHz ±200Hz	8831.5kHz ±200Hz				
	IF SHIFT VR : Center							More than 8832.5kHz				
	: MAX							Less than 8830.5kHz				
	2) Turns IF shift VR to the center after check.											
8 VCO voltage	1) FREQ. : 30.000.00	DC V.M	RF	⑦ -2	RF	L62	6.0V	5.9~6.1V				
	FREQ. : 26.200.00 <b>W2</b>						4.6V <b>W2</b>	4.5~4.7V <b>W2</b>				
	MODE : AM						Check	2.6~3.3V				
	2) FREQ. : 21.500.00											
	3) FREQ. : 21.499.99							⑦ -3	RF	L60	6.0V	5.9~6.1V
	4) FREQ. : 14.500.00										Check	2.2~2.9V
	5) FREQ. : 14.499.99									L58	6.0V	5.9~6.1V
	6) FREQ. : 7.500.00										Check	2.7~3.3V
	7) FREQ. : 7.499.99									L56	6.0V	5.9~6.1V
8) FREQ. : 30.00 (30kHz) <b>150kHz W2</b> <b>2MHz X</b>					Check	2.7~3.3V <b>2.8~3.4V W2</b> <b>3.6~4.0V X</b>						
9 BPF	1) Tracking Generator output : -20dBm Connect the Tracking generator to ANT terminal.	Tracking generator	RF	TP1	RF	L15, L17	1.8~2.5MHz					
	2) FREQ. : 3.000.00	Spectrum analyzer				L18, L20	2.5~3.5MHz					
	3) FREQ. : 5.000.00		L21, L23	3.5~5.5MHz								
	4) FREQ. : 7.000.00		L24, L26	5.5~7.5MHz								
	5) FREQ. : 10.000.00		L27, L29	7.5~10.5MHz								
	6) FREQ. : 14.000.00		L30, L32	10.5~14.5MHz								

# ADJUSTMENT

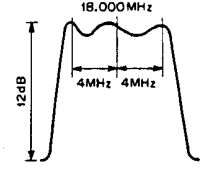
3

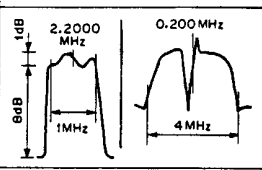
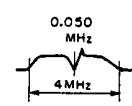
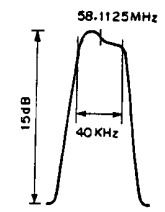
Item	Condition	Measurement			Adjustment		Specification/Remarks	
		Test equipment	Unit	Terminal	Unit	Part		Method
	7) FREQ. : 21.000.00					L33, L35	14.5~21.5MHz	
	8) FREQ. : 30.000.00					L36~ 38	21.5~30.0MHz	
	9) FREQ. : 1.500.00							
	10) FREQ. : 500.00* * Except X type.							
10. MCF	1) Tracking generator output : -20dBm Connect the tracking generator to TP1 in the RF unit.	Tracking generator	IF	TP1	RF	L50	Larger waveform perform shown on right.	
	2) Short TP4 and TP5 in the IF unit.	Spectrum analyzer			IF	L4 L1~3	Larger waveform perform shown on right.	
11. IF	1) FREQ. : 14.100 MODE : USB SSG output : 14.100.0dBμ Short TP4 and TP5 in the IF unit. Beat FREQ. : 1kHz	SSG AF V.M OSCILLO	Rear panel	EXT.SP	IF	L4,7,8 L9,10 L15,16 L19 L21,22	Repeat 2 times.	MAX. AF output.
12. RF	1) Condition is the same as item 11.	SSG AF V.M OSCILLO	Rear panel	EXT.SP	RF	L48, L50	MAX. AF output.	
13. MIX BM	1) FREQ. : 150.00 (150kHz)	SSG AF V.M OSCILLO	Rear panel	EXT.SP	RF	VR1	MIN. AF noise level VR : center (mechanically) X	
14. PLL MIX BM	1) FREQ. : 888.50 (kHz) FREQ. : 2.888.5 (MHz) X MODE : AM SSG output : 890.0kHz, 60dBμ 2.89MHz, 60dBμ X	SSG AF V.M OSCILLO	Rear panel	EXT.SP	PLL	VR1	MIN AF output	Less than 85dB.
15. IF TRAP	1) FREQ. : 2~2.499 SSG output : 58.1125MHz, 80dBμ	SSG AF V.M	Rear panel	EXT.SP	RF	L44	MIN. AF beat output.	Less than 85dB.
16. NB	1) FREQ. : 14.100.00 MODE : USB SSG output : 14.100MHz, 10dBμ	SSG DC V.M	IF	TP2	IF	L11,13 14	MIN. voltage	Less then 2.9V.

## ADJUSTMENT

Item	Condition	Measurement			Adjustment			Specification/Remarks
		Test equipment	Unit	Terminal	Unit	Part	Method	
17. FM IF	1) MODE : FM SSG MOD : 1kHz DEV : 5kHz output : 60dB $\mu$	SSG AF V.M OSCILLO	Rear panel	EXT.SP	IF	L25	MAX. AF output.	
18. Carrier point	1) IF unit VR8 : MIN SSG : OFF	SP	Rear panel	EXT.SP	SW (B/8)	VR7	Turn LSB, USB mode alternately to get the same noise sounds occur.	
	2) After adjustment VR8 : Center							
19. S-meter	1) FREQ. : 14,100.00(14.1MHz) MODE : USB AGC : FAST • $\phi$ point SSG output : OFF Short TP4 and TP5 in the IF unit  Remove the short wire after adjustment.	SSG AF V.M  DC V.M OSCILLO	IF	TP3	IF	VR2	2.9V	2.88~2.92V
						VR3	MAX.	
			Front panel	S-meter		VR4	S-meter "2"	
			IF	TP3		VR2	3.0V	2.98~3.02V
	2) S9 SSG output : 32dB $\mu$ AF output : 1kHz	Front panel	S-meter		VR3	S-meter "9"		
	3) The edge-rising SSG output : 10dB $\mu$ 4) Repeat 2) and 3) two times.				VR1	S-meter "2"		
20. D-AGC	1) Same as item 19. SSG output : 92dB $\mu$	SSG	Front panel	S-meter	IF	VR5	S-meter "60dB"	
	2) SSG output : 32dB $\mu$						Check S-meter "9".	
21. SSB SQL	1) SSG output : OFF SQL VR : 11:00	SSG			IF	VR6	Adjust VR slowly and stop at threshold.	
	2) SQL VR : 10:00						Check the noise sound	
	3) SQL VR : 12:00						Check the noise goes off.	
	4) SQL VR : Threshold SSG output : 12dB $\mu$						Check the squelch open.	
	5) After check SQL VR : MIN							
22. FM SQL	1) FREQ. : 28.675.00 FREQ. : 26.100.00 <b>W2</b> MODE : FM SSG output : OFF (28.675MHz)	SSG					Adjust VR slowly and stop at threshold.	SQ. VR 8:30~10:30
	2) SSG MOD : 1kHz DEV : 3kHz output : -4dB $\mu$						Check	Squelch open.
	3) Tight SQL-1 SQL VR : MAX SSG output : 12dB $\mu$							
	4) Tight SQL-2 SSG output : 120dB $\mu$							
	5) After check SQL VR : MIN							
23. NOTCH	1) SSG output : 60dB $\mu$ AF output : 1kHz, 0.63V/8 $\Omega$ NOTCH : ON	SSG				NO-TCH VR7	MIN. output	The remainder between NOTCH ON and OFF is more than 35dB.
	2) Beat FREQ. : 2.6kHz : 500Hz						Check	More than 30dB (same as above.)

# ADJUSTMENT

Item	Condition	Measurement			Adjustment			Specification/Remarks
		Test equipment	Unit	Terminal	Unit	Part	Method	
24. Sensitivity check	1) FREQ. : 29,900.00 (29.9MHz) FREQ. : 26,100.00 (26.1MHz) <b>W2</b> : 29.9MHz, -6dBμ : 26.1MHz, -6dBμ <b>W2</b>	SSG						S/N more than 10dB (AF GAIN VR : MAX) 0.63V/8Ω
25. ANT2	1) ANT2 SW : ON							ANT2 LED lit on.
	2) Apply a signal to ANT2 50Ω terminal and 500Ω terminal.						Check	Adjust 500Ω terminal AF output is less than 50Ω terminal.
26. Filter select check	1) SELECTIVITY : N	DC V.M SP	IF	D38			Voltage check	8.5~9.5V
	2) SELECTIVITY : M1			D39				
	3) SELECTIVITY : M2			D40				
	4) SELECTIVITY : W			D41				
	5) After check SELECTIVITY : AUTO							
27. Marker check	1) Connect the cable between MKR terminal on the PLL and the RF unit. FREQ. : 15,000.00	SP						Check of possible receive.
	2)							
28. BEEP sound	1) AF GAIN VR : Center RF GAIN VR : MIN Depress <b>MODE</b> key	OSCILLO	Rear panel	EXT.SP	IF	VR8	Adjust as shown below. 	300~500mV

## Microprocessor operation check

Item	Condition	Operation check	Item	Condition	Operation check
1. Reset	1) Power SW : ON While depressing the <b>A=B</b> key.	<div style="text-align: center;">A VFO 00 15.000000</div> AM LED : Lights ANT1 : Lights	2. Function	11) Depress the <b>A/B</b> key once.	<div style="text-align: center;">VFO B 00 15.000000</div> AM LED : Lights ANT1 LED : Lights
2. Function	1) Depress the BAND <b>UP</b> key once.	<div style="text-align: center;">A VFO 00 16.000000</div>		12) Depress the <b>STEP</b> key once.	<div style="text-align: center;">VFO B      STEP 00 15.000000</div> STEP display : Lights
	2) Depress the BAND <b>DOWN</b> key once.	<div style="text-align: center;">A VFO 00 15.000000</div>		13) Depress the <b>STEP</b> key once.	<div style="text-align: center;">VFO B 00 15.000000</div> STEP display : Lights
	3) Turn the ENCODER clockwise.	FREQ. : UP		14) Depress the <b>ANT2</b> key once.	<div style="text-align: center;">VFO B 00 15.000000</div> ANT2 LED : Lights
	4) Turn the ENCODER counterclockwise.	FREQ. : DOWN		15) Depress the <b>ANT1</b> key once.	<div style="text-align: center;">VFO B 00 15.000000</div> ANT1 LED : Lights
	5) Depress the <b>LSB</b> key once.	LSB LED : Lights Beep sound : ---		16) <b>F.LOCK</b> : ON	F. LOCK LED : Lights
	6) Depress the <b>USB</b> key once.	USB LED : Lights Beep sound : ---		17) <b>F.LOCK</b> : OFF	F. LOCK LED : Goes off
	7) Depress the <b>CW</b> key once.	CW LED : Lights Beep sound : ---		18) Depress the "HF/VHF" key once.	<div style="text-align: center;">A VFO 145.000000</div> FM LED : Lights Holds above display momentarily, then goes HF again. Beep sound
	8) Depress the <b>AM</b> key once.	AM LED : Lights Beep sound : ---			
	9) Depress the <b>FM</b> key once.	FM LED : Lights Beep sound : ---			
10) Depress the <b>FSK</b> key once.	FSK LED : Lights Beep sound : ---				

## ADJUSTMENT

Item	Condition	Operation check
2. Function	19) CLOCK SW : CLOCK1 20) CLOCK SW : CLOCK2 21) CLOCK SW : OFF	Displays the clock function Displays the clock function. The clock function display disappear.
3. Enter check	1) Depress each key in the following order : [ENT] → [1] → [6] → [7] → [8] → [9] → [ENT]	VFO B 00 16.789.00
4. Memory write.	1) Depress the [M.IN] key once.	M.CH B 00 . . M.SCR LED : Lights
	2) Depress the [0] [8] key once.	M.CH B 08 . .
	3) Depress the [M.IN] key once.	VFO B 08 16.789.00
	4) Depress the BAND [UP] key once.	VFO B 08 17.789.00
	5) Depress the [M.IN] key once.	M.CH B 08 16.789.00
	6) Depress the BAND [UP] key once.	M.CH B 09 . .
	7) Depress the [M.IN] key once.	VFO B 09 17.789.00
	8) Depress the [VFO/M] key once.	M.CH B 09. 17.789.00
	9) Depress the BAND [DOWN] key once.	M.CH B 08 16.789.00
	10) Depress the [SCAN] key once.	Scanning Memory CH 08 and 09. SCAN display : Lights
	11) Depress the [CLEAR] key once.	Scan stop
	12) Depress the [M] [V] key once.	VFO B 16.789.00 or : VFO B 17.789.00

Item	Condition	Operation check
4. Memory write	13) Depress the [SCAN] key once.	SCAN VFO B P0 . . . The display steps up 1kHz at each key-press.
	14) Depress the [CLEAR] key once.	SCAN display disappear. P0 display disappear then display Memory channel.
5. Timer check (ON TIME SET)	1) CLOCK SW : CLOCK1 TIME SET SW : ON Depress the [HOUR] [MINUTE] keys at the same time.	Colon (:) blinking stops.
	2) TIMER SW : ON Depress the "ON TIME" SW once.	on . . 00:00
	3) Set the timer with the [HOUR] [MINUTE] keys while depressing the "ON TIME" SW.	on 00.00 00:00
	4) TIMER SW : ON TIME SET SW : ON Depressing the "OFF TIME" SW once.	off . . 00:00
	5) Set the timer with the [HOUR] [MINUTE] keys while depressing the "OFF TIME" SW.	off 00.00 00:00
	6) TIMER SW : OFF	Colon (:) blinking
	7) TIMER SW : OFF	Display * : Lights
	8) POWER SW : OFF	Power stays ON if the set time is in ON TIME. If ON TIME set is before the displayed time, it shows * [ : ] . . 00:00
	9) When reached timer period	ON/OFF check
	10) POWER SW : ON TIMER SW : OFF	* display disappear Normal operation
Note : Timer function is stops while time setting, therefore, displayed time is different from actual time. After adjust the timer follow the TIME SET item 6. The time setting of ON TIME and OFF TIME works as same time setting on both CLOCK1 and CLOCK2.		
6. TIME (CLOCK 1)	1) CLOCK SW : CLOCK1 TIME SET SW : ON Depress the [HOUR] [MINUTE] keys at the same time.	Colon (:) blinking stops.
	2) Set the timer with [HOUR] [MINUTE] keys.	Time set is possible.
	3) TIME SET SW : OFF	Colon (:) blinking and the clock function starts. From this moment, "second" starts from zero second.
	(CLOCK 2) 4) CLOCK SW : CLOCK2 Perform other operations same as CLOCK1, and check the action is all the same.	

# ADJUSTMENT

TOP VIEW

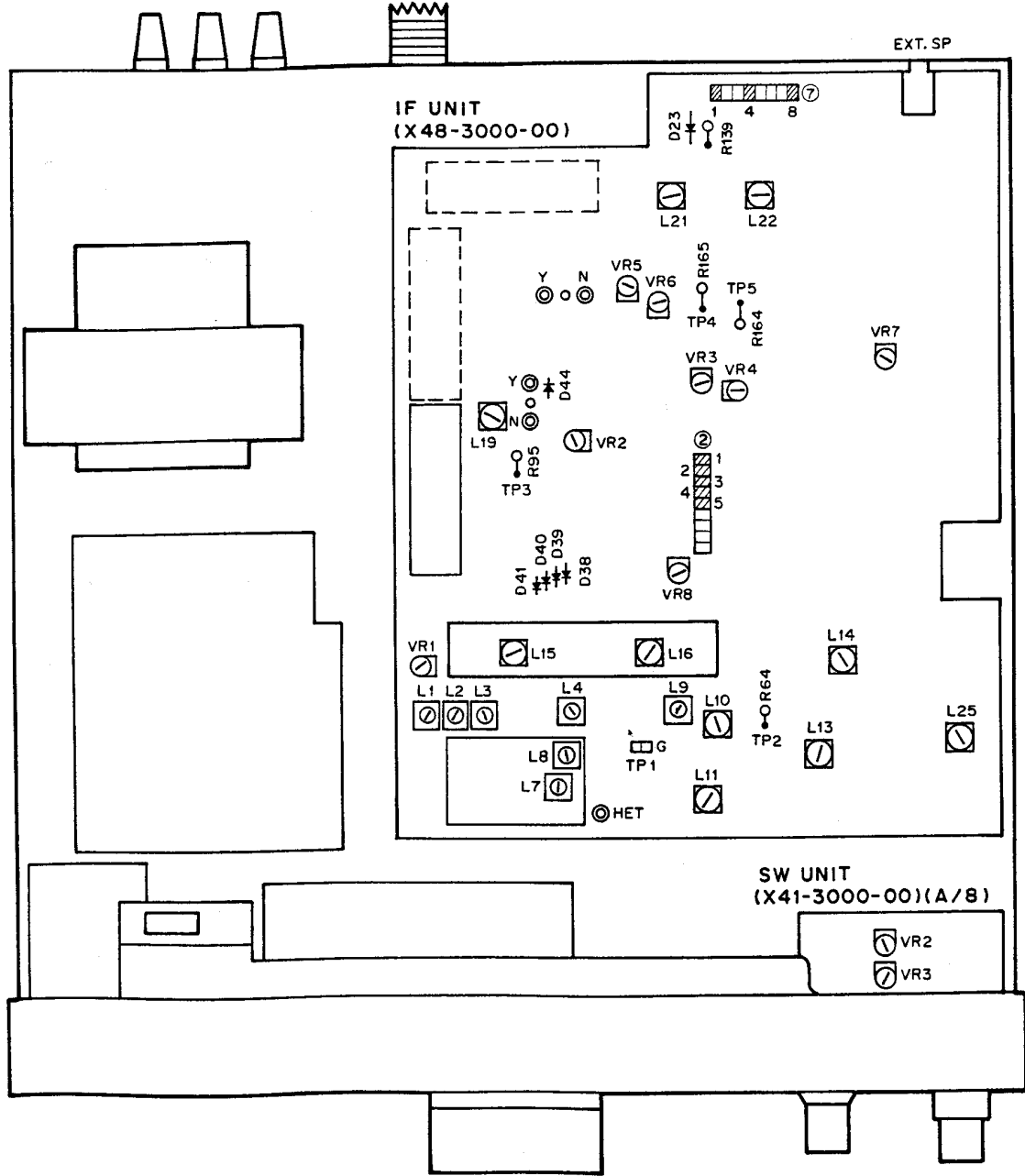

## ADJUSTMET

BOTTOM VIEW

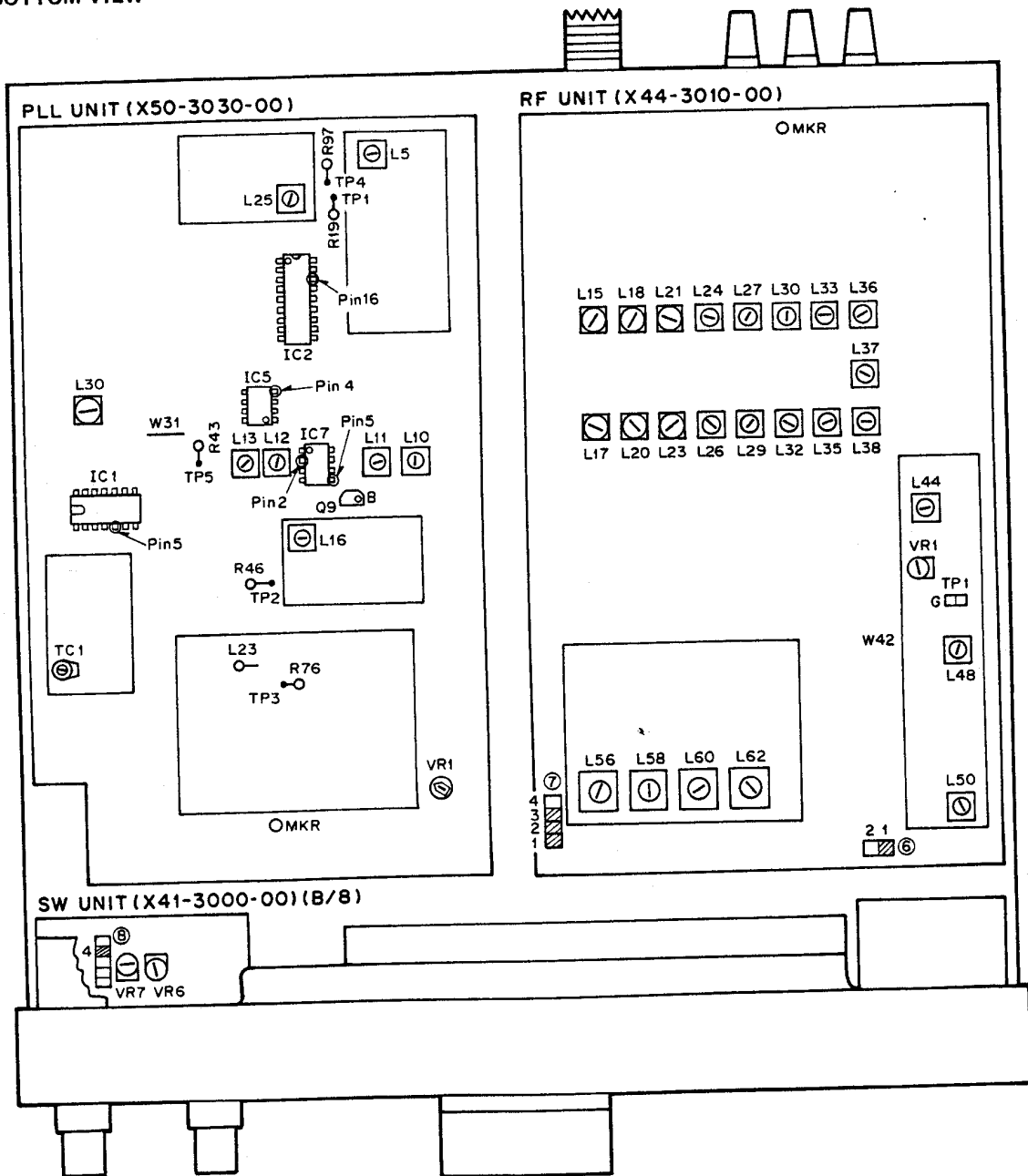

# LEVEL DIAGRAM

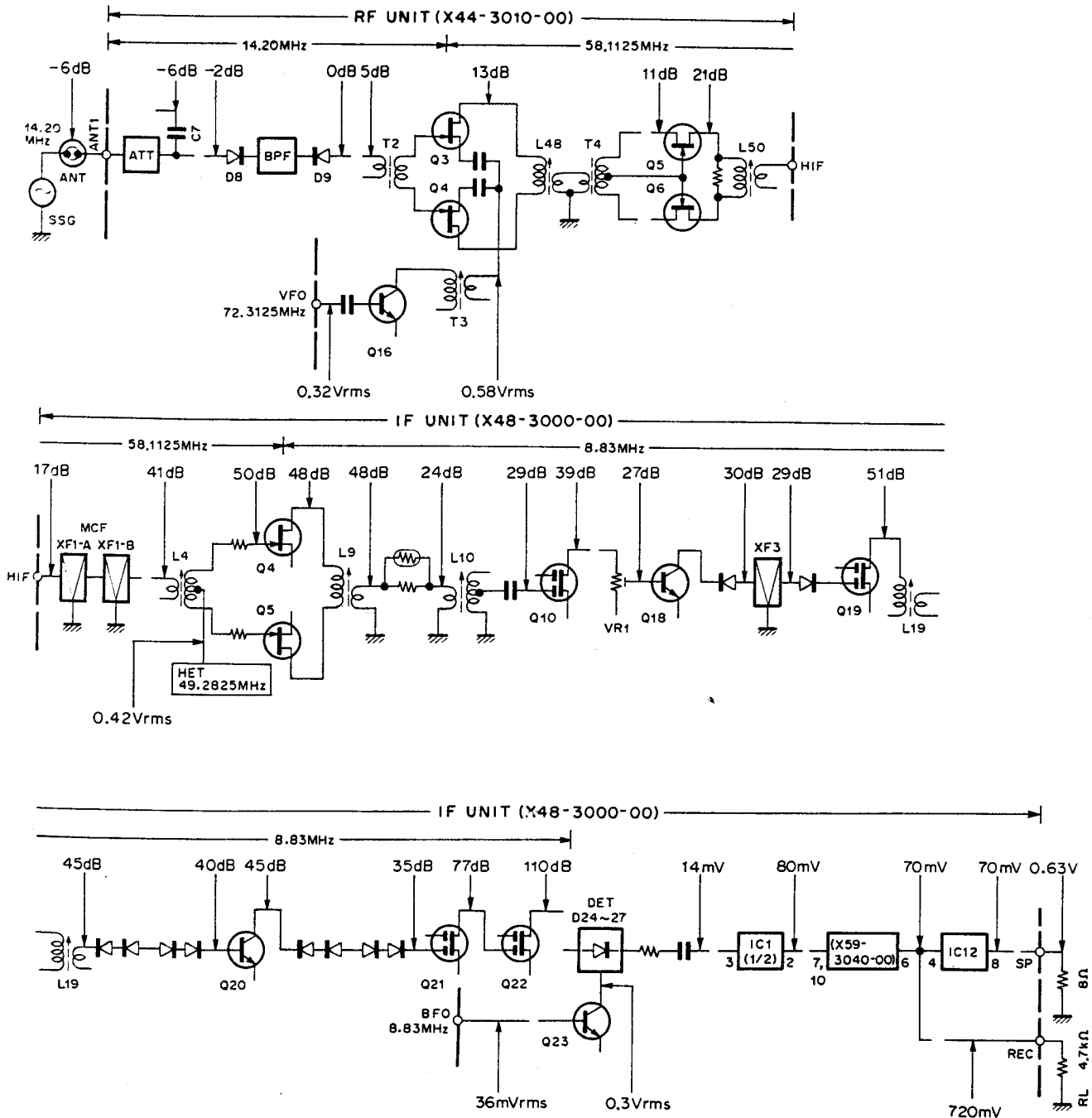

Frequency : 14.200MHz  
 Input : -6dBμ  
 AF output : 0.63V/8Ω  
 Mode : USB

1. A -6dBμ 14.200MHz SSG signal is applied at the ANT terminal, the AF GAIN VR is adjusted to produce an audio output of 0.63V/8Ω, and then the SSG signal levels at various points that are required to the same audio output with the AF GAIN VR left unchanged are plotted.
2. The SSG output signal should always be connected through a titanium oxide porcelain capacitor of 0.01μF, 50WV.

# BLOCK DIAGRAM

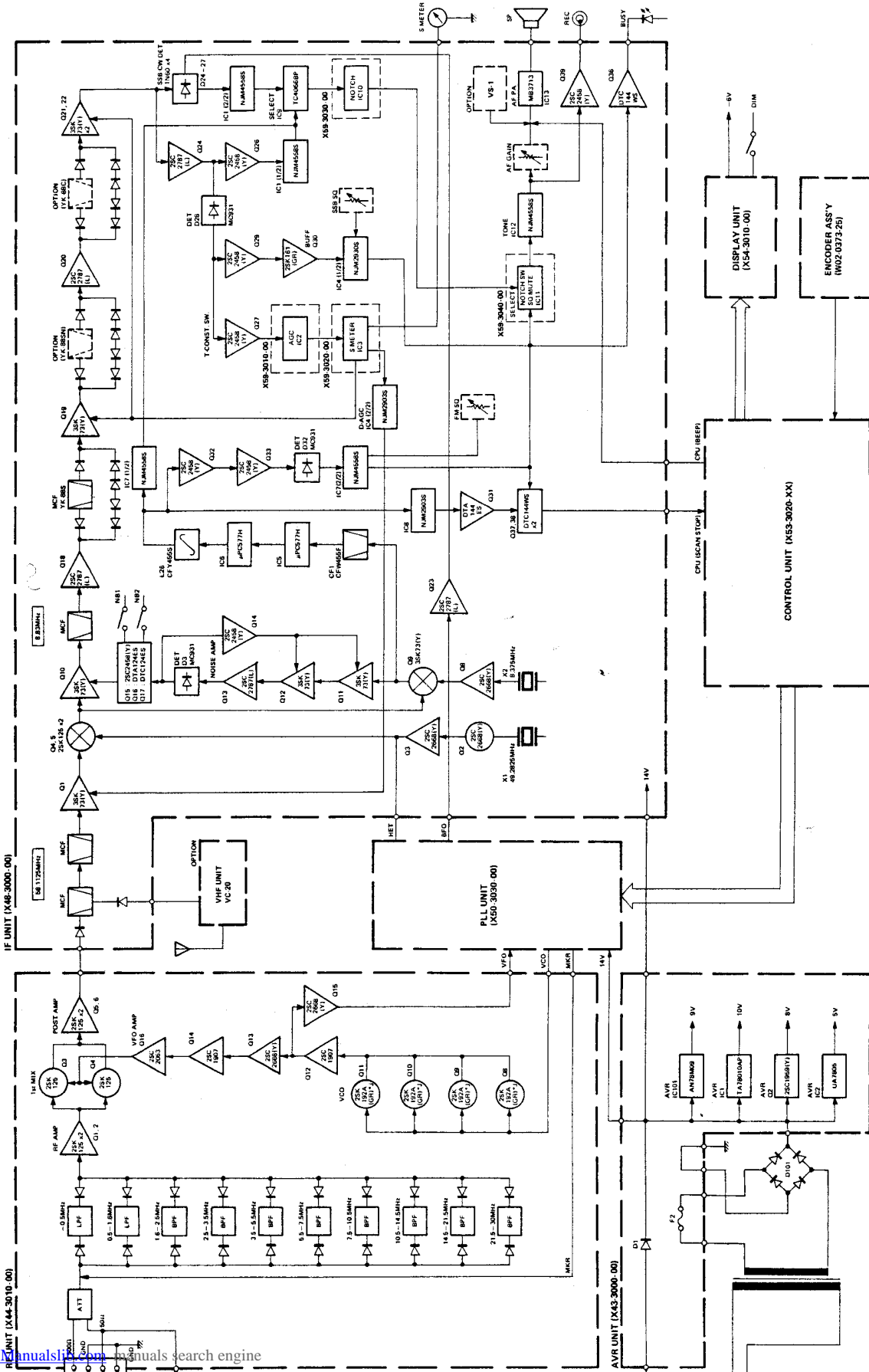

▼ RF UNIT (X44-3010-00) Component side view

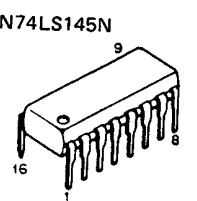
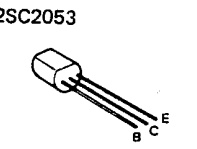
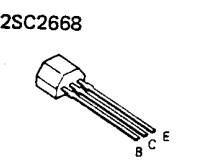
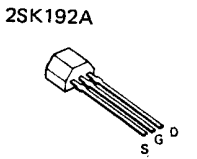
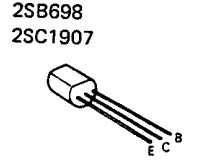
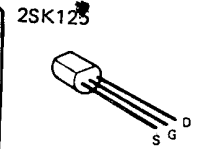
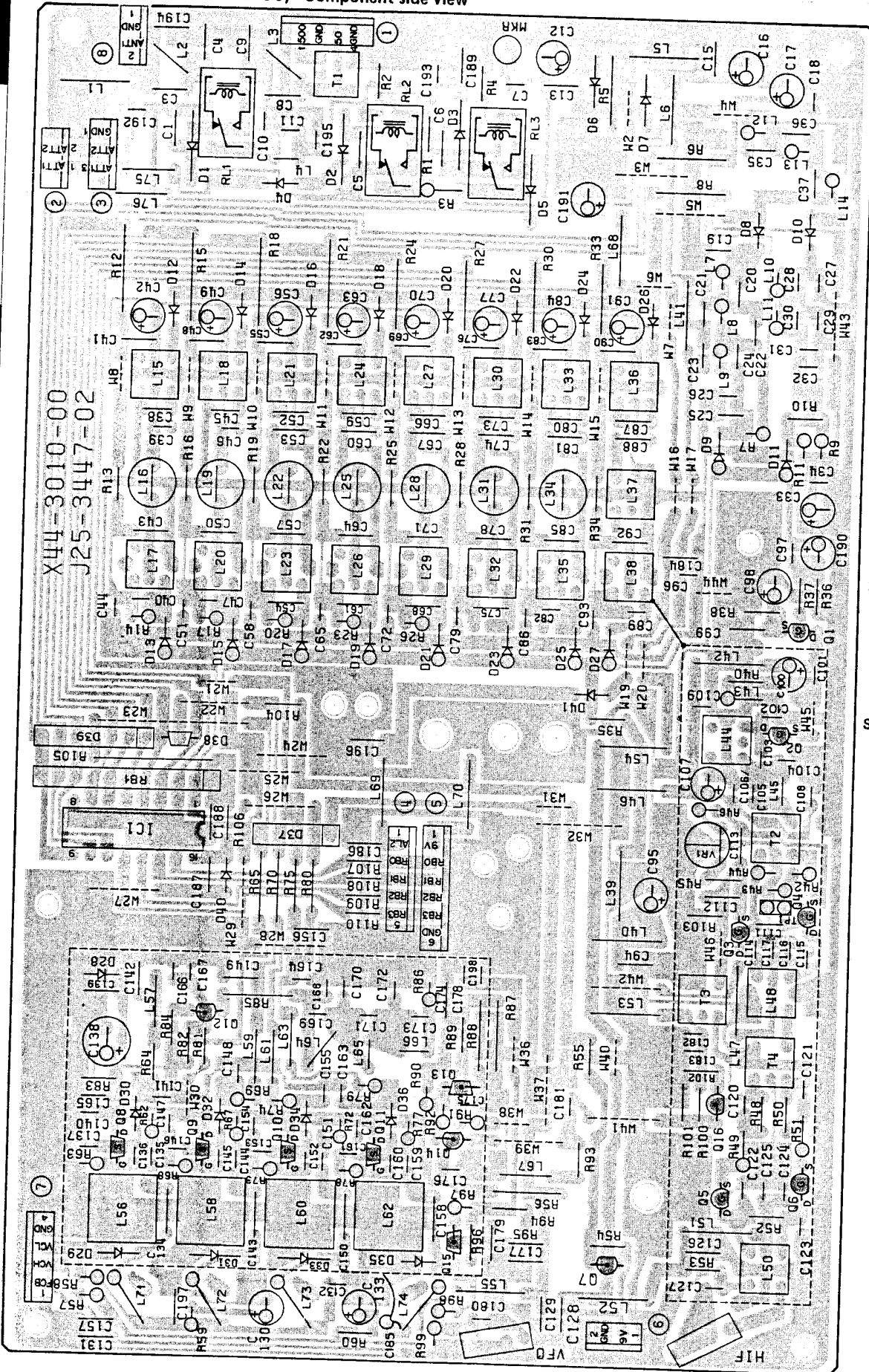

2

3

▼ RF UNIT (X44-3010-00)

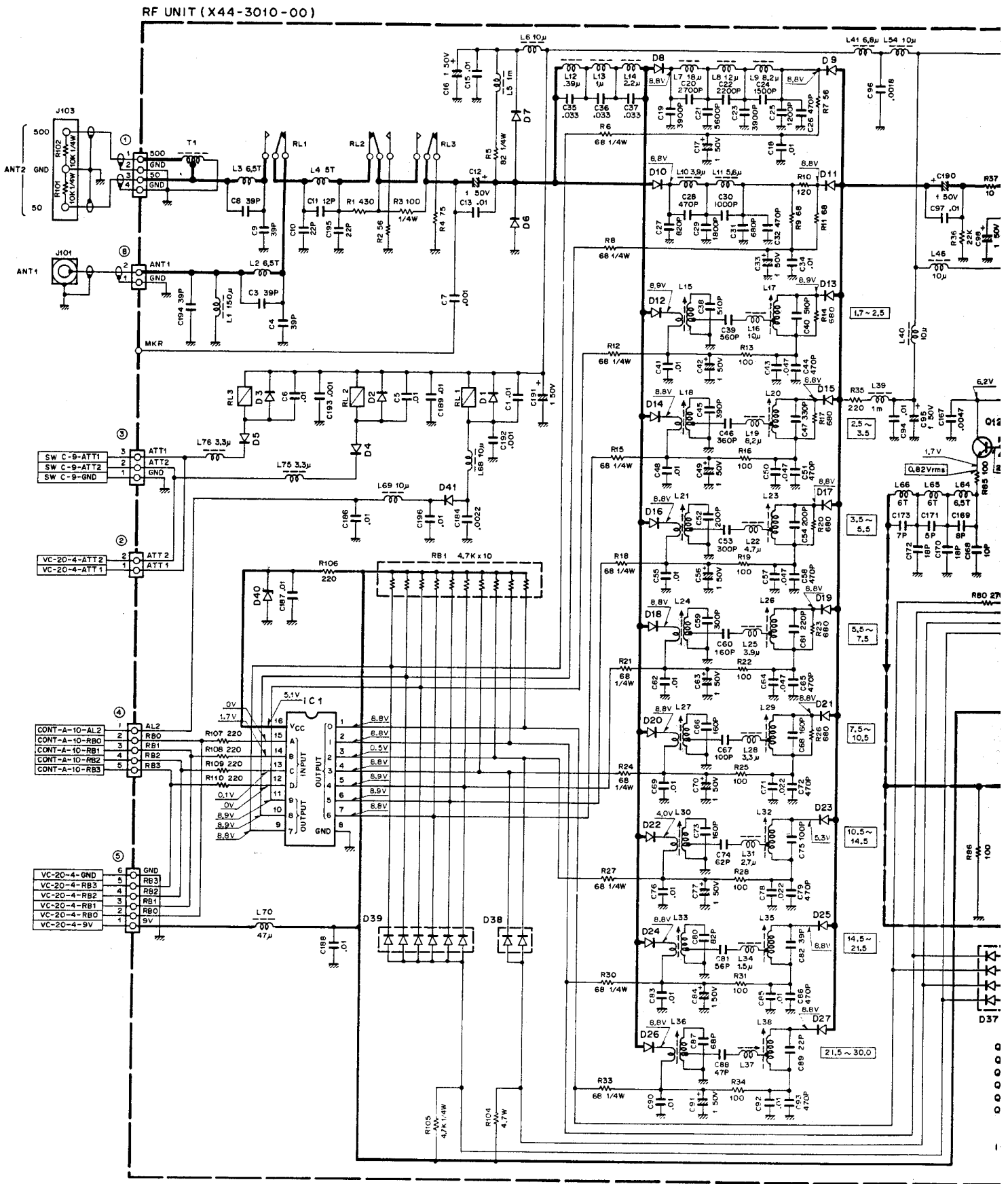

**CAUTION :** For continued safety, replace safety critical components only with manufacturer's recommended parts (refer to parts list).  
 ⚠ indicates safety critical components. To reduce the risk of electric shock, leakage-current or resistance measurements shall be carried out (exposed parts are acceptably insulated from the supply circuit) before the appliance is returned to the user.

# CIRCUIT DIAGRAM R-5000

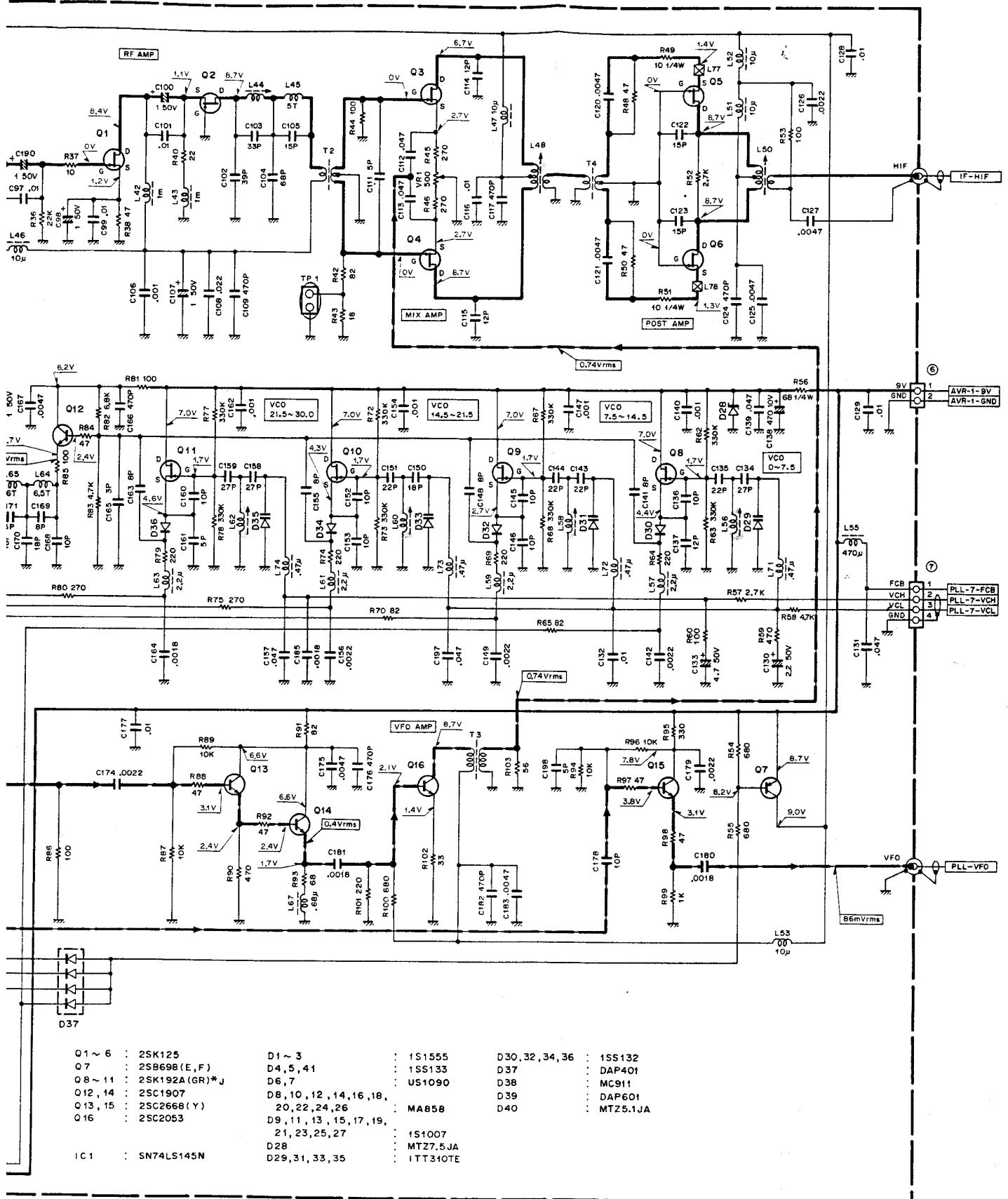

Q1 ~ 6	: 2SK125	D1 ~ 3	: 1S1555	D30, 32, 34, 36	: 1S5132
Q7	: 2SB698(E,F)	D4, 5, 41	: 1S5133	D37	: DAP401
Q8 ~ 11	: 2SK192A(GR)*J	D6, 7	: US1090	D38	: MC911
Q12, 14	: 2SC1907	D8, 10, 12, 14, 16, 18, 20, 22, 24, 26	: MA858	D39	: DAP601
Q13, 15	: 2SC2668(Y)	D9, 11, 13, 15, 17, 19, 21, 23, 25, 27	: 1S1007	D40	: MTZ5.1JA
Q16	: 2SC2053	D28	: MTZ7.5JA		
IC1	: SN74LS145N	D29, 31, 33, 35	: ITT310TE		

▼ AGC (X59-3010-00) Component side view

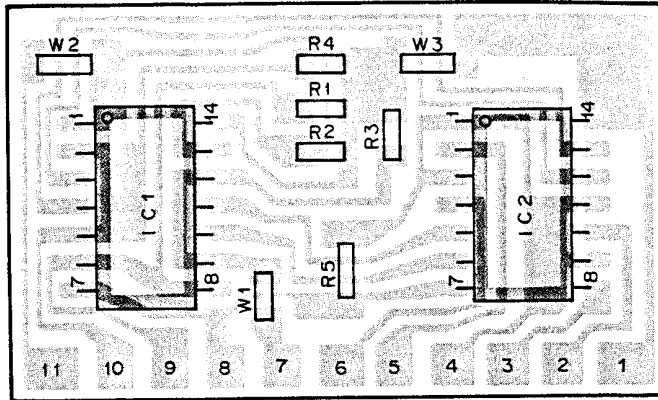

3SK73

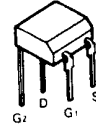

2SC2668 2SC3113  
2SC2458 2SC2459

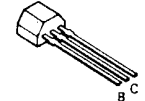

DTC114ES DTC144ES  
DTC144WS DTC124ES

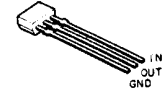

DTA124ES DTA114ES  
DTA144ES

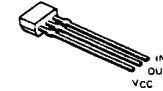

2SK125

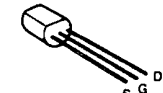

2SC2787

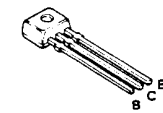

2SK161

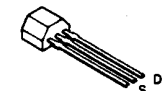

NJM4558S

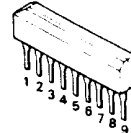

NJM2903S

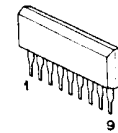

μPC577H

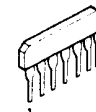

TC4066BP TC4071BP

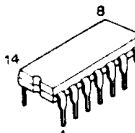

▼ S meter (X59-3020-00) Component side view

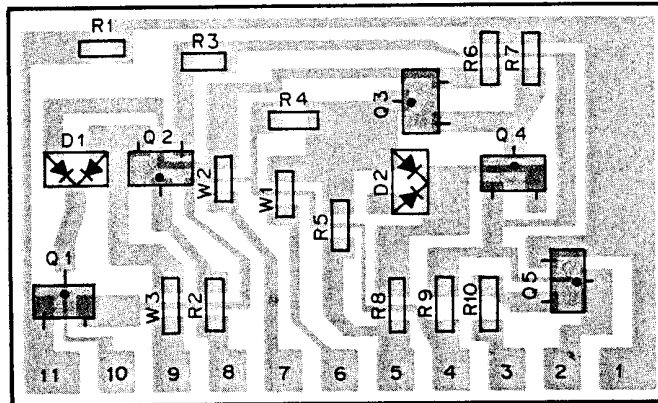

▼ NOTCH (X59-3030-00) Component side view

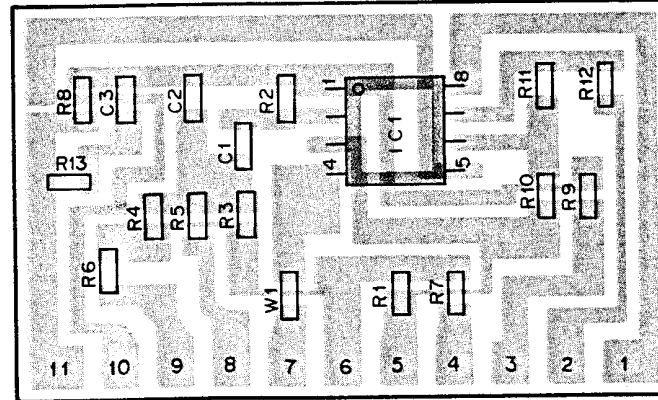

▼ SELECT (X59-3040-00) Component side view

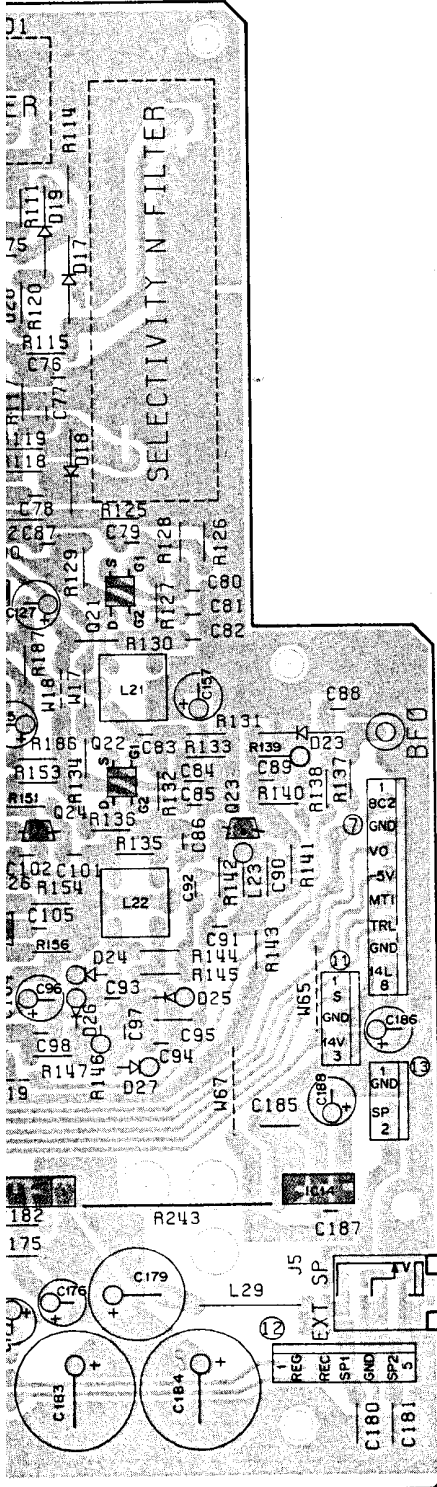
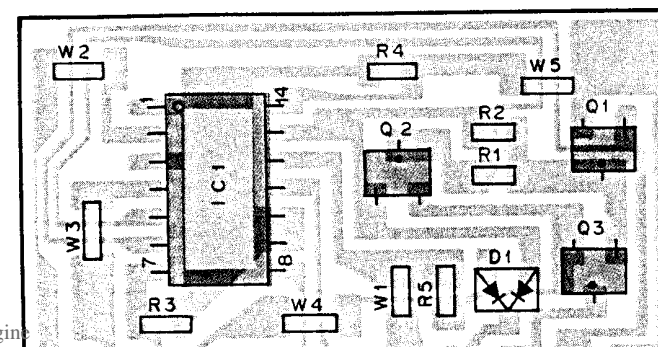

DTC144WK

# R-5000 PC BOARD VIEWS

IF UNIT (X48-3000-00) Component side view

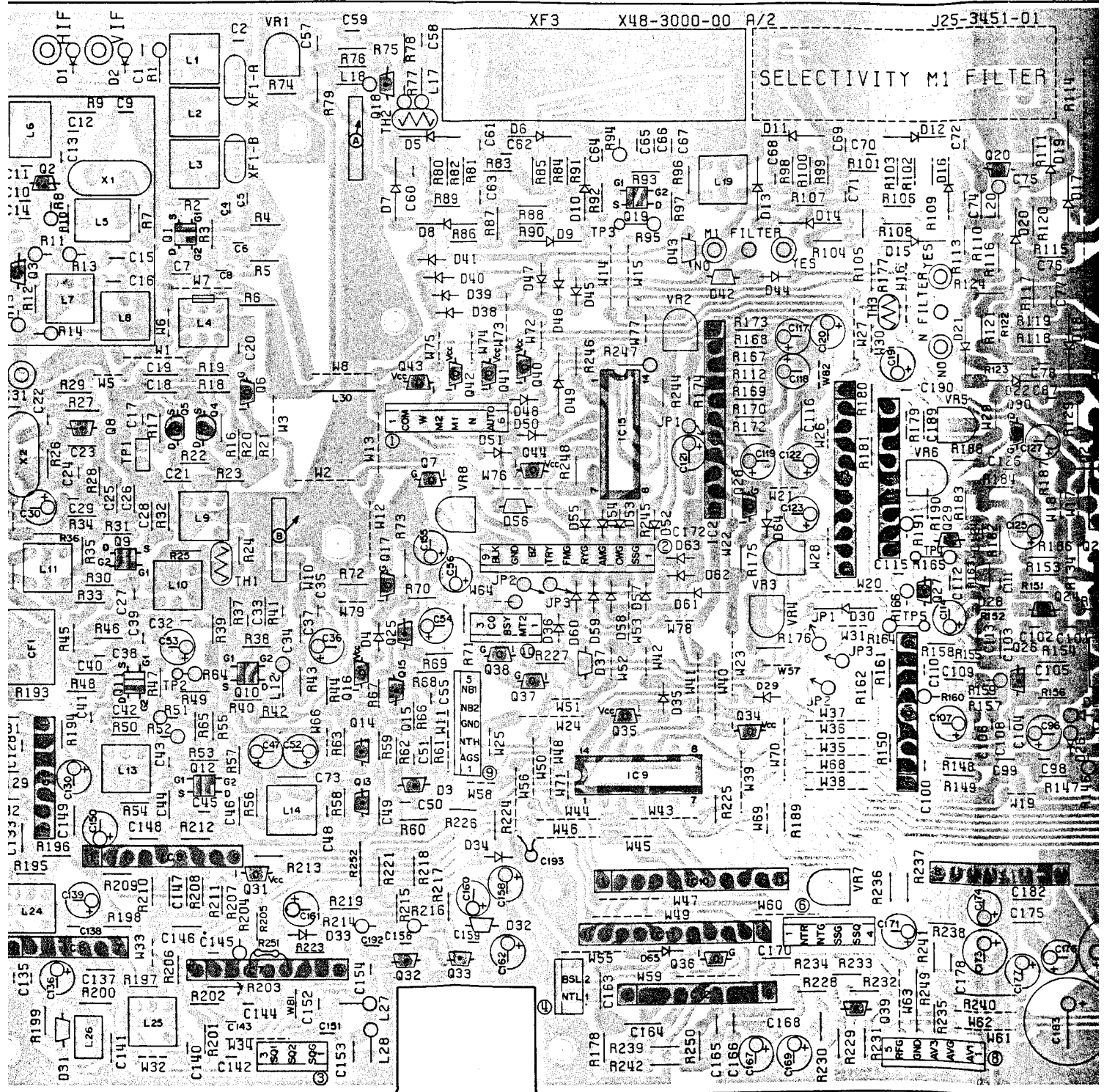
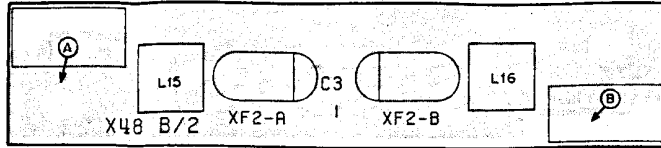

- I713
- AN78N09
- TC4001BF
- 2SC2712
- DTA124EK
- 2SK211
- NJM4558M
- TC4066BF
- 2SA1162
- IN
- OUT



# CIRCUIT DIAGRAM R-5000

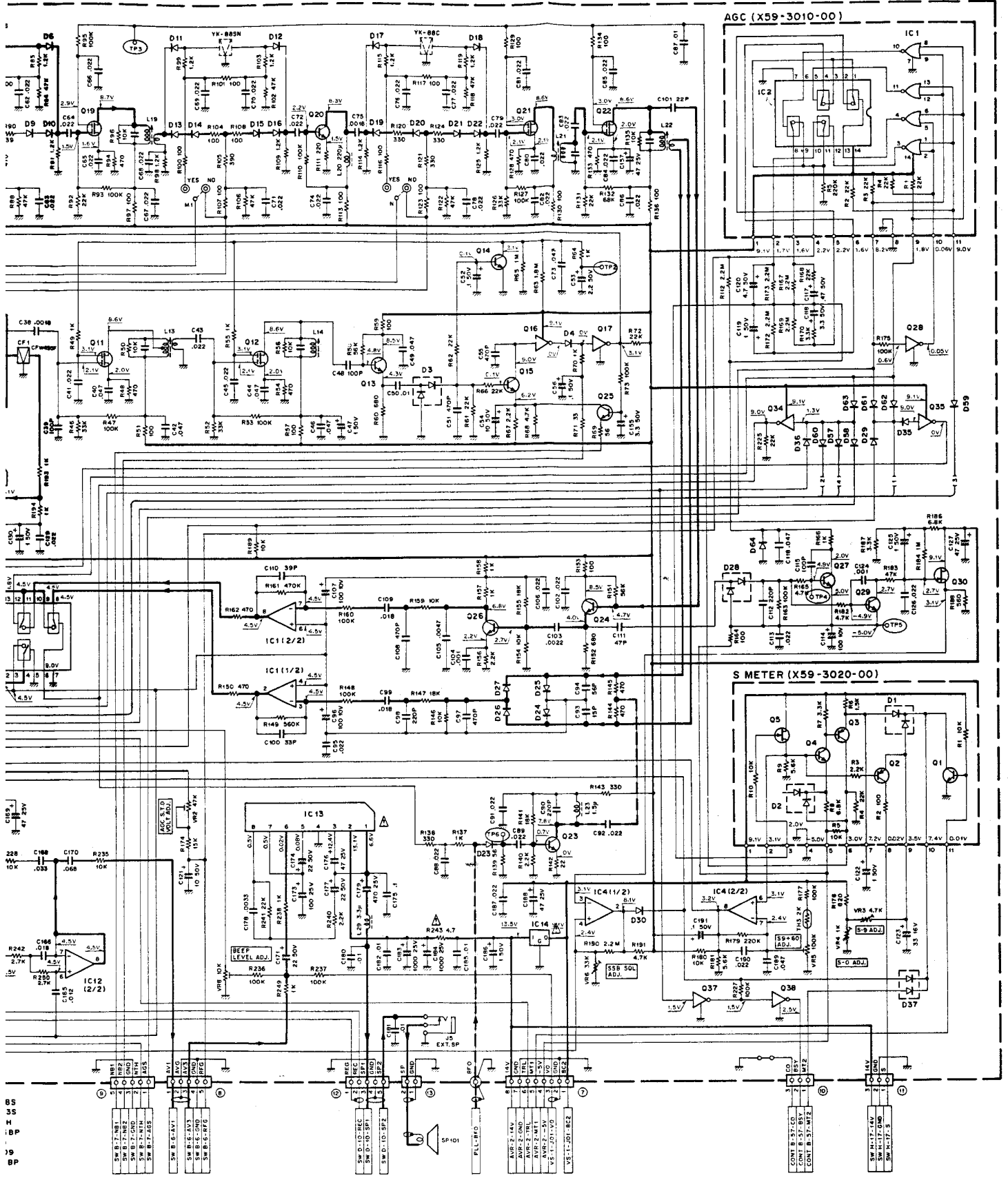

(X59-3010-00)  
 IC1 : TC4001BF  
 IC2 : TC4066BF

(X59-3020-00)  
 O 1, 4 25C2712(V)  
 O 2, 3 25A1162(V)  
 O 5 25K 211(6R)  
 D 1, 2 DAN202K

(X59-3030-00)  
 IC1 : NJM4558M

(X59-3040-00)  
 O 1, 9 DTA124EK  
 O 2, 3 DTC144WK  
 IC 1 TC4066BF  
 D 1 DAN202K

# R-5000 CIRCUIT DIAGRAM

PLL UNIT (X50-3030-00)

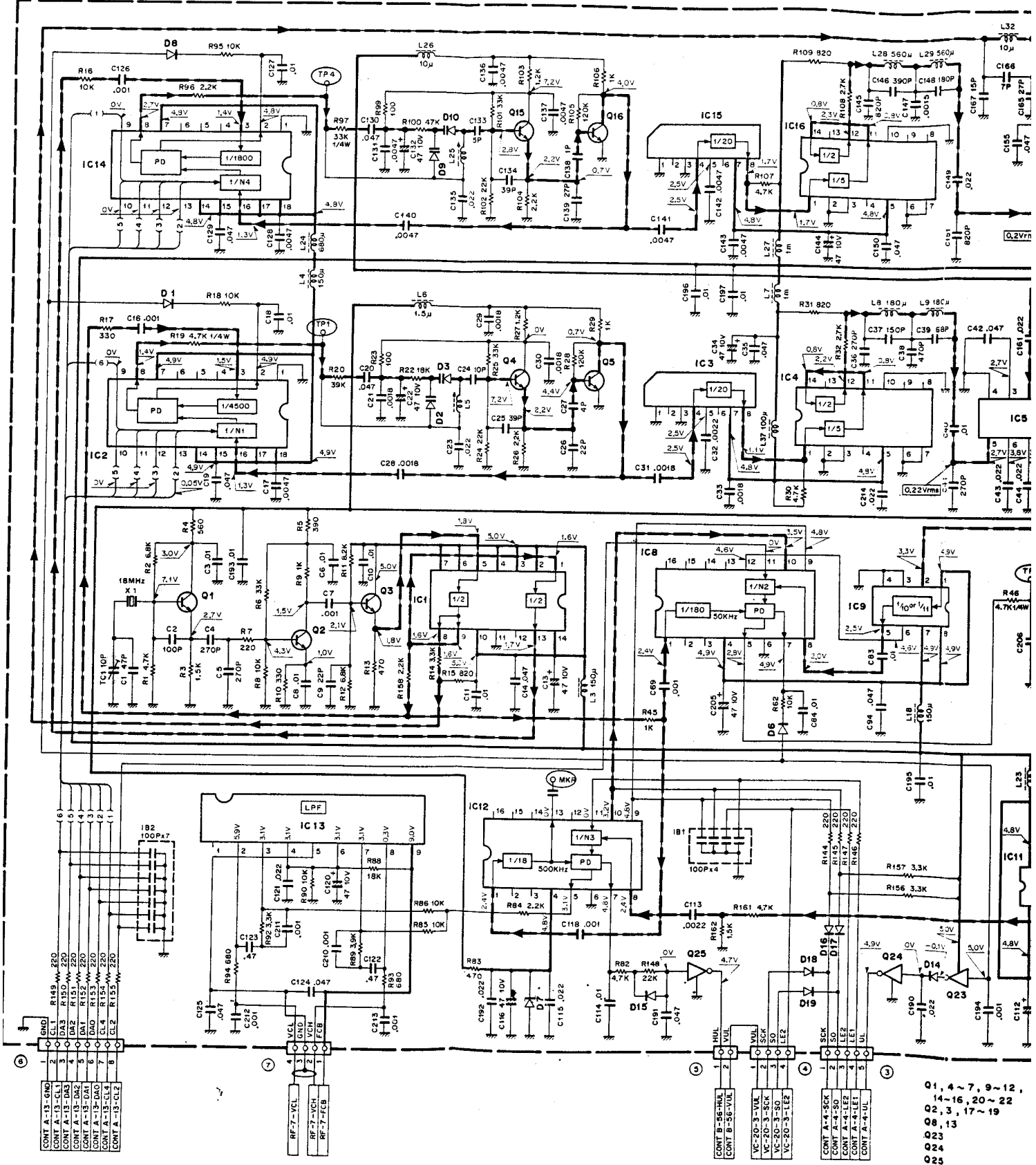

▼ PLL UNIT (X50-3030-00)

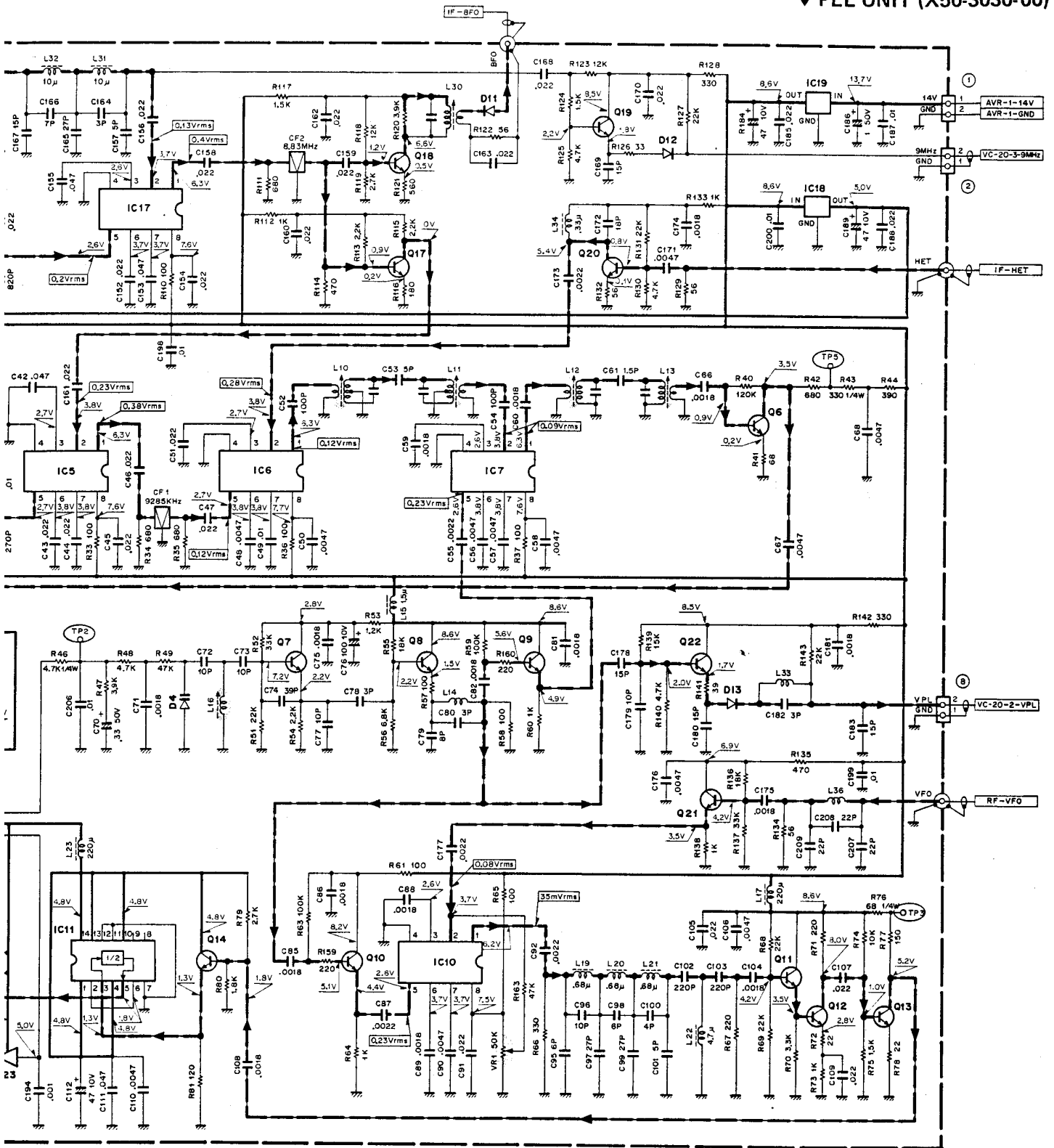

~ 7, 9~12, 16, 20~22	23C2668 (Y)	IC 1	SN74LS73AN	IC 11	SN74S74N	D 1, 6, 8, 14, 15	1SS133
17~19	23C2787 (L)	IC 2, 14	MN6147C	IC 13	BA718	D 2, 3	ITT310TE
	23C1907	IC 3, 15	M54459L	IC 18	AN78N05	D 4, 9, 10	1SV153
	DTA124ES	IC 4, 16	SN74LS90N	IC 19	AN78M09	D 7	MTZ5.1JA
	DTC124ES	IC 5 ~ 7, 10, 17	SN16913P			D 11~13	1S1587
	DTC144WS	IC 8, 12	M887006			D 16~19	BA282
		IC 9	µPB551C				

# PC BOARD VIEW R-5000

▼ PLL UNIT (X50-3030-00) Component side view

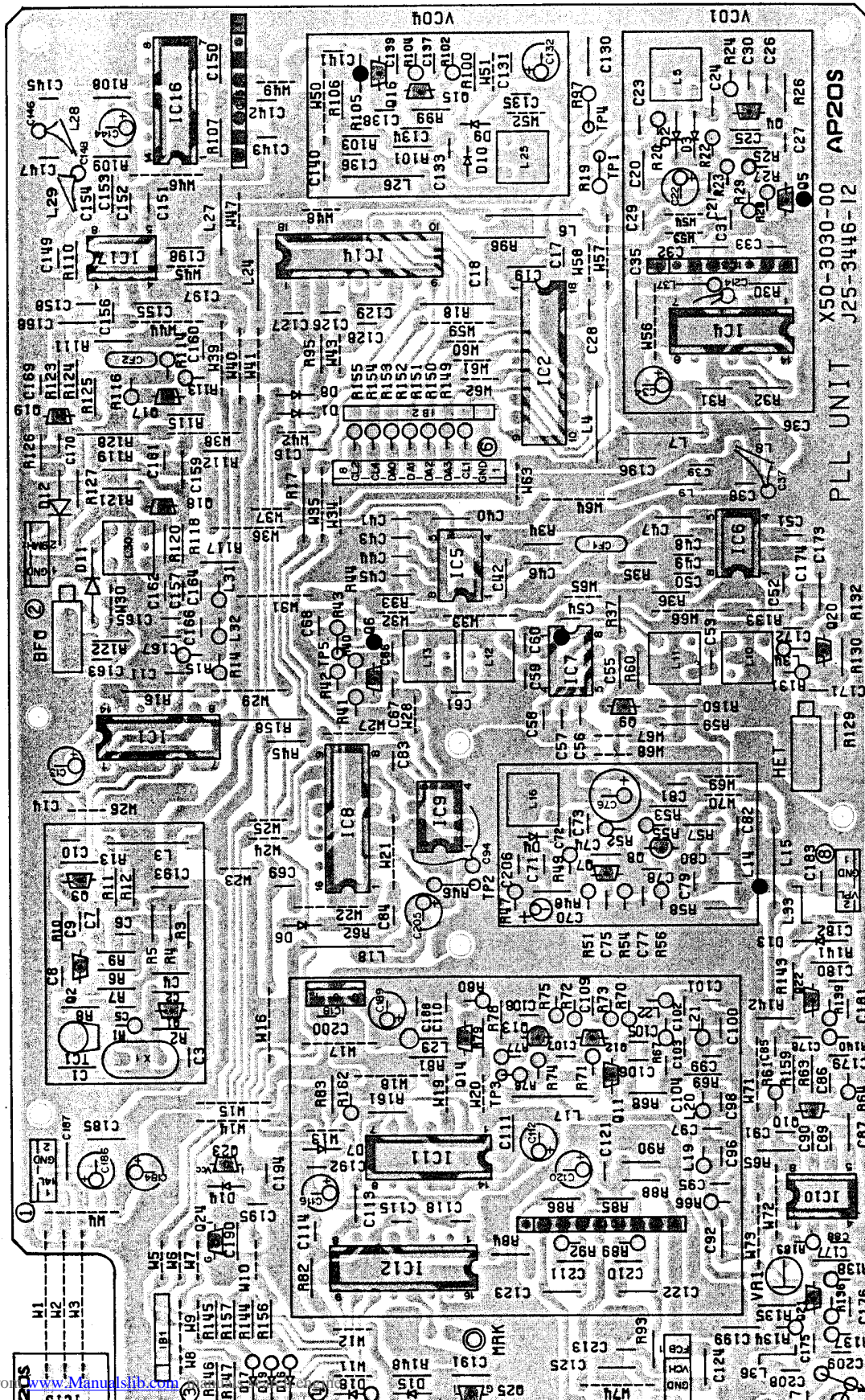

SN74LS73AN SN74S74N  
SN74LS90N



MN6147C

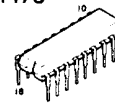

M54459L

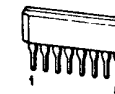

SN16913P

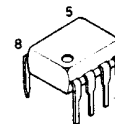

MB87006

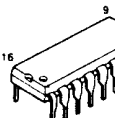

μPB551C

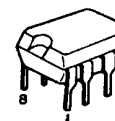

BA718

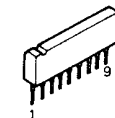

AN78N05 AN78M09

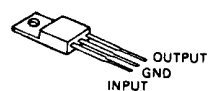

2SC2668(Y)

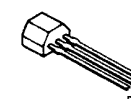

DTA124ES

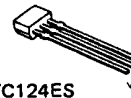

DTC124ES  
DTC144WS

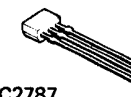

2SC2787

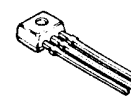

2SC1907

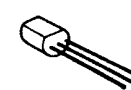

# R-5000 PC BOARD VIEW

▼ CONTROL UNIT (X53-3020-00) Component side view -11: K,M,T,W1 -61: W2 -71: X

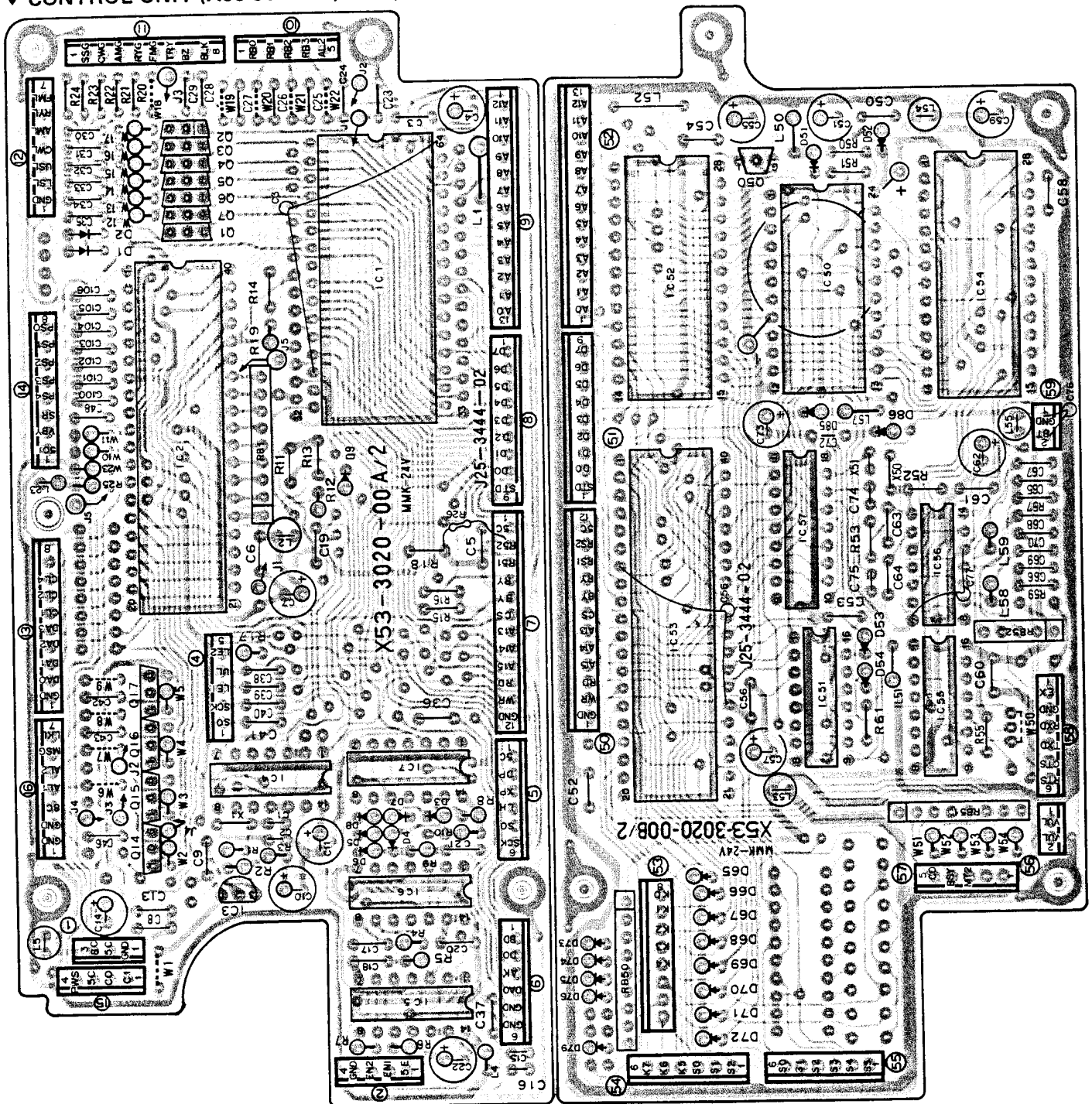

μPD7800G

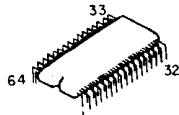

M5M82C55AP-5

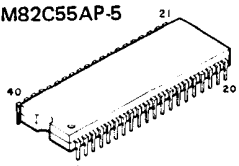

PST520D

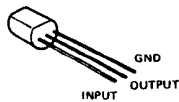

TC4011BP TC4069UBP  
TC4030BP

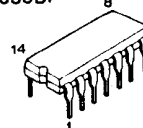

DTC143ES  
DTC144WS

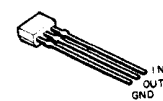

MB8418-20LP-GR

SN74LS138N

MBM27128-25JB1

SN7404N

MSM6242RS

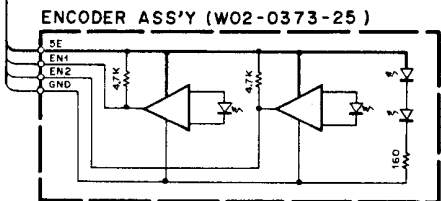
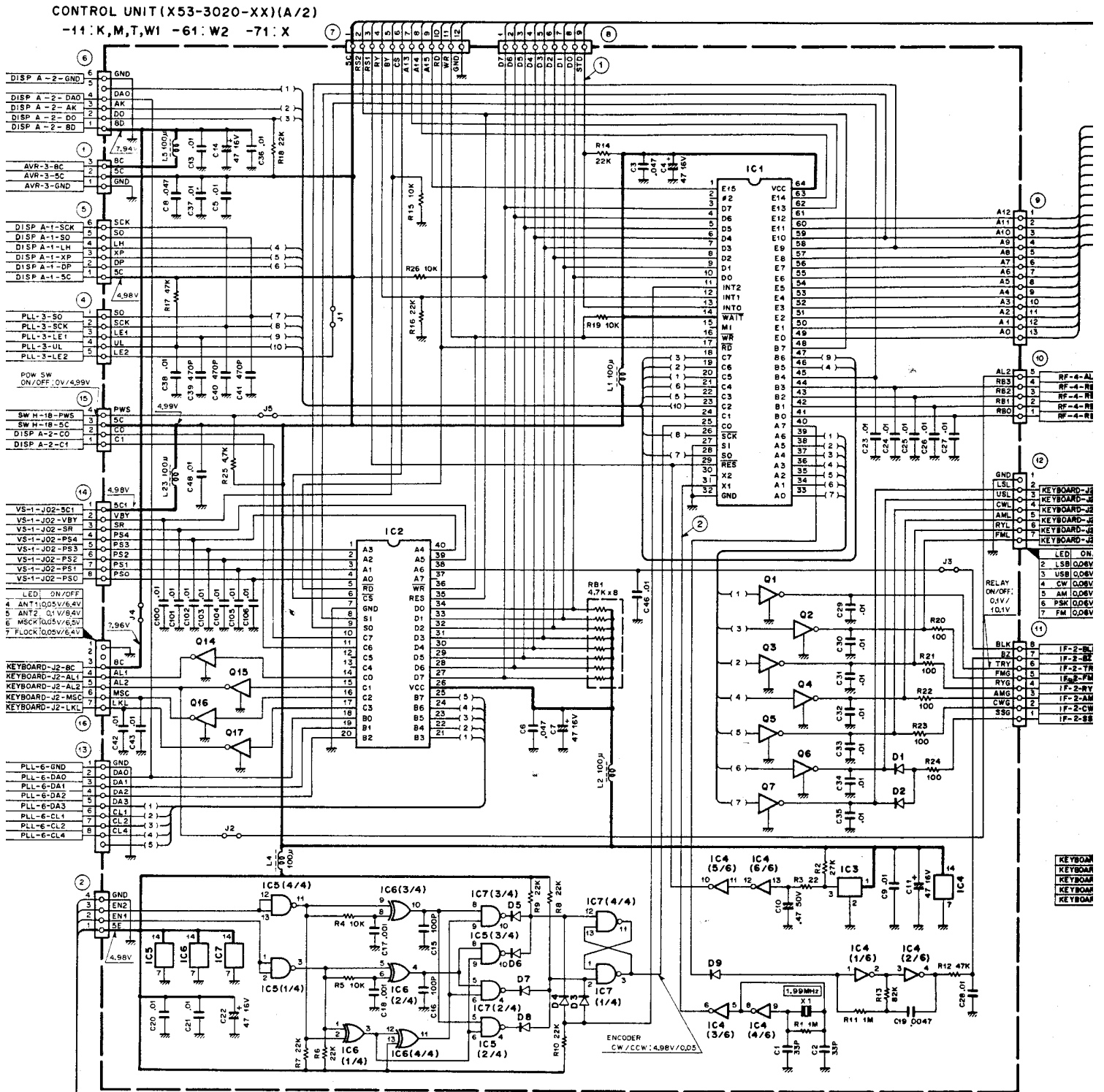

- IC1 : µPD7800G
- IC2 : M5M82C55AP-5
- IC3 : PST520D
- IC4 : TC4069UBP
- IC5,7 : TC4011BP
- IC6 : TC4030BP

- Q1-7, 14-17 : DTC143ES
- D1-9 : 1SS133

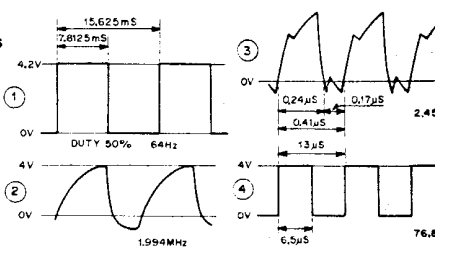

**CAUTION :** For continued safety, replace safety critical components only with manufacturer's recommended parts (refer to parts list).  
 ▲ indicates safety critical components. To reduce the risk of electric shock, leakage-current or resistance measurements shall be carried out (exposed parts are acceptably insulated from the supply circuit) before the appliance is returned to the user.

# CIRCUIT DIAGRAM R-5000

CONTROL UNIT (X53-3020-XX)(B/2) -11:K,M,T,W1 -61:W2 -71:X

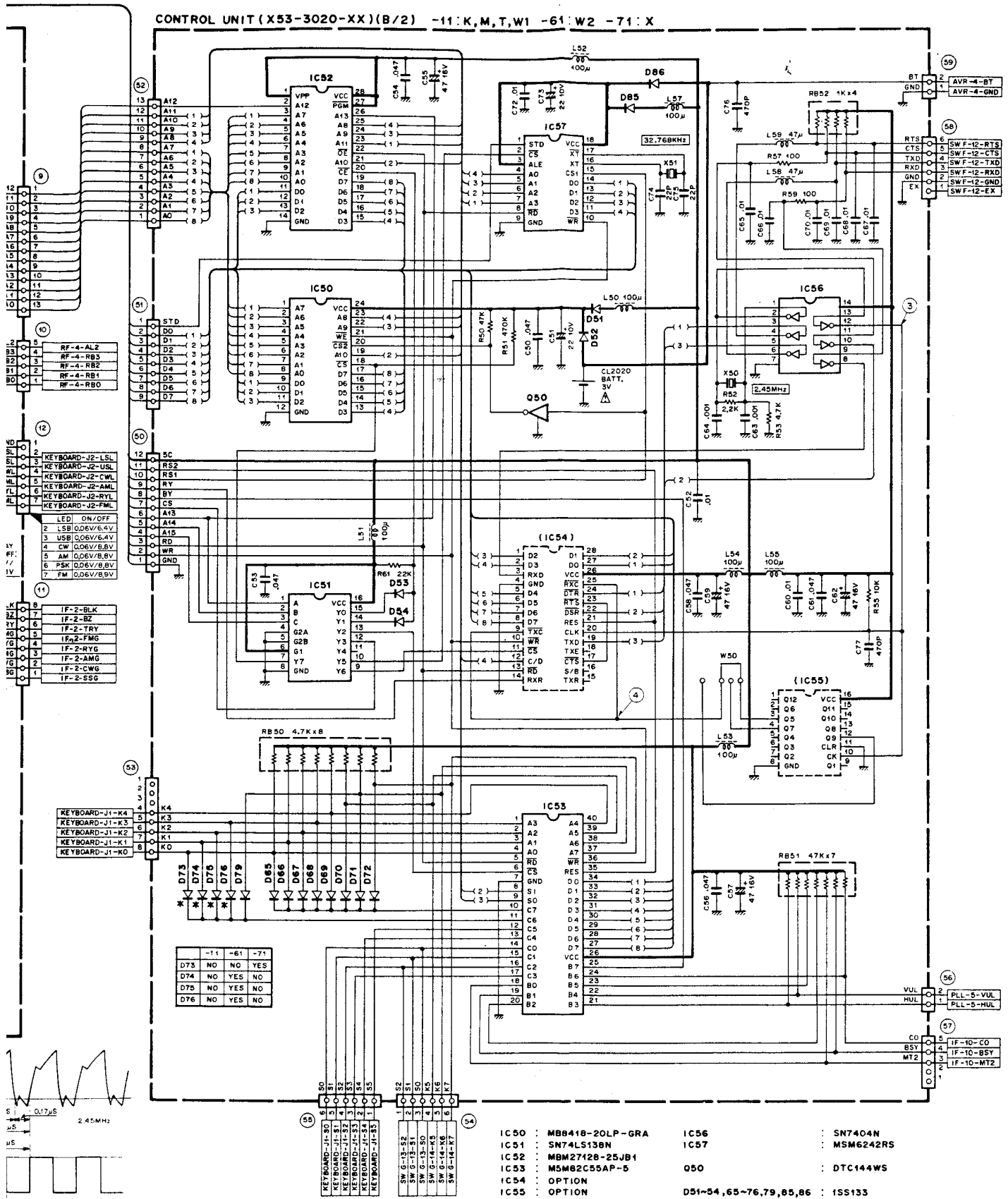

▼ SWITCH UNIT (X41-3000-00) Component side view

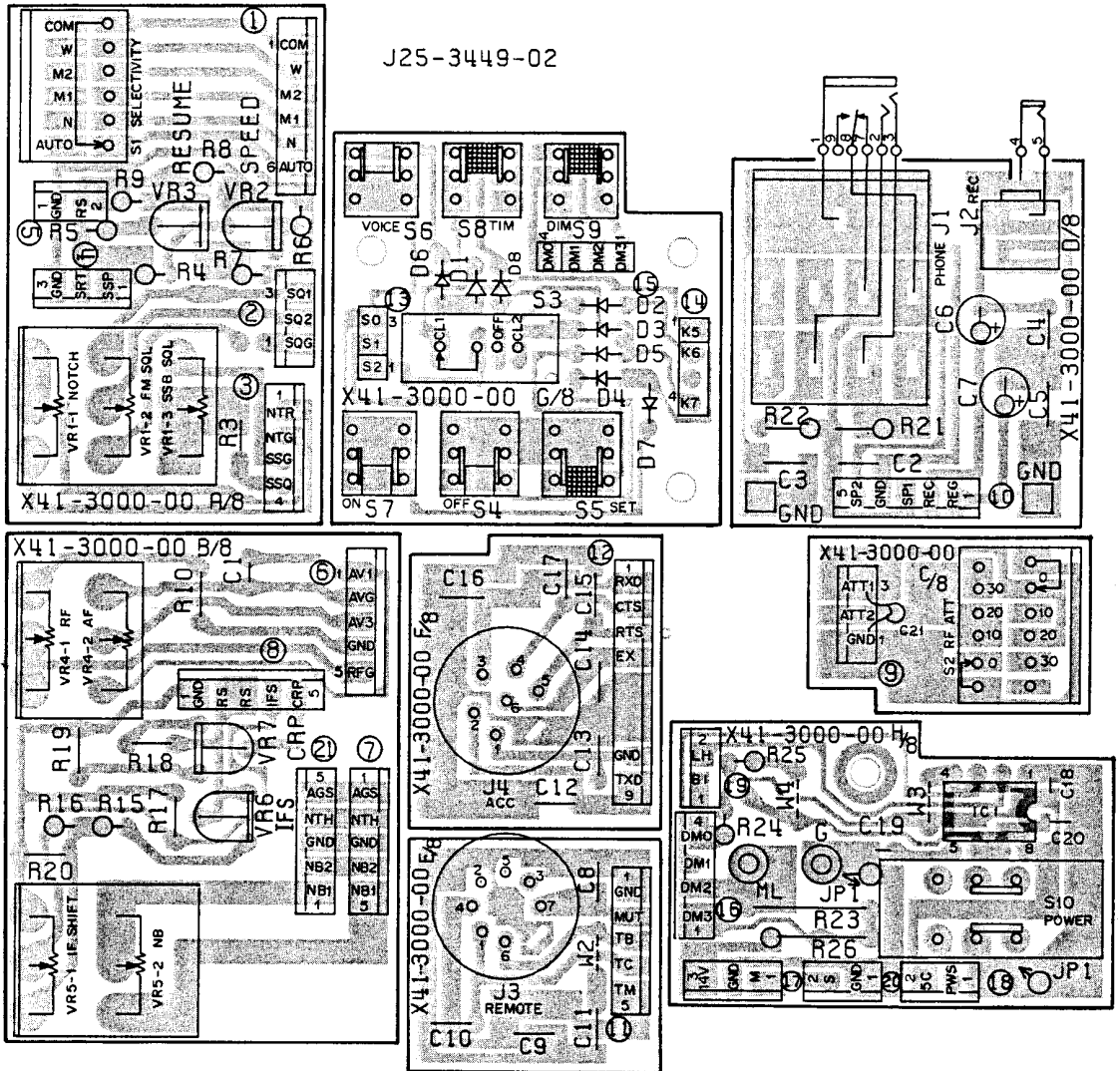

▼ AVR UNIT (X43-3000-00) Component side view

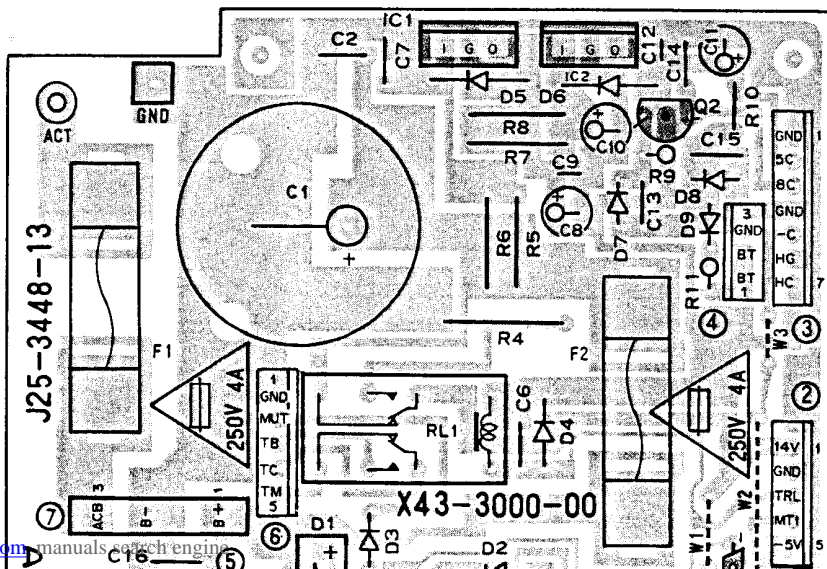

# R-5000 PC BOARD VIEWS

▶ DISPLAY UNIT (X54-3010-00) Component side view

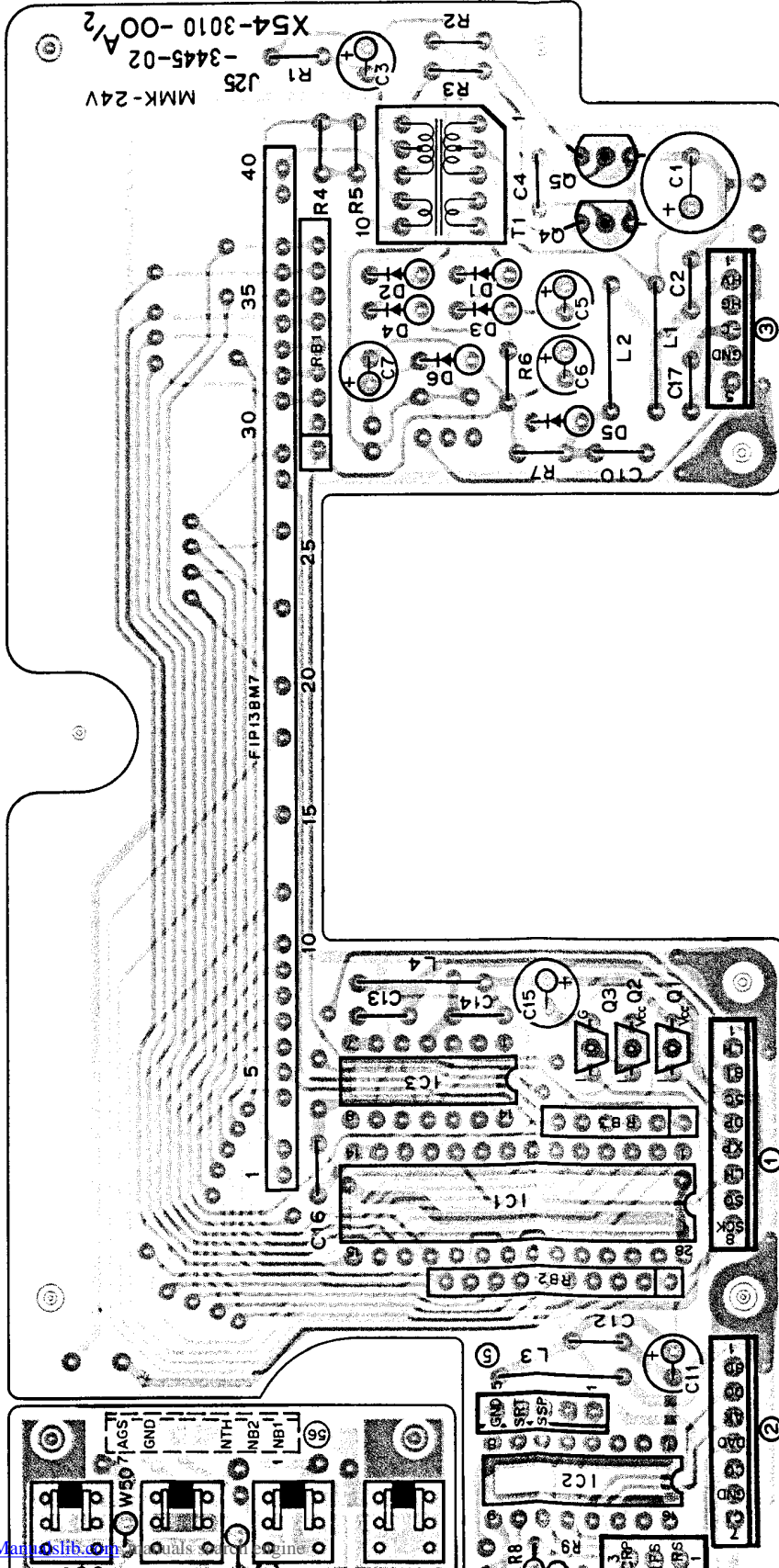

DTA114ES

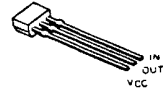

DTC124ES  
DTC144WS

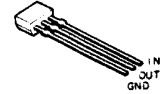

2SC1959

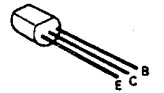

μPD6300C

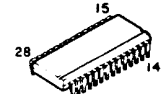

MB4052

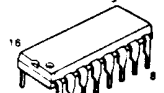

TC4013BP

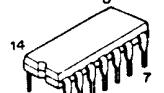

TA78010AP

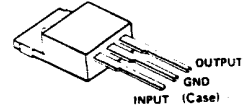

UA7805

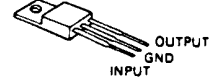

NE555P

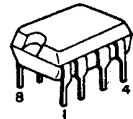

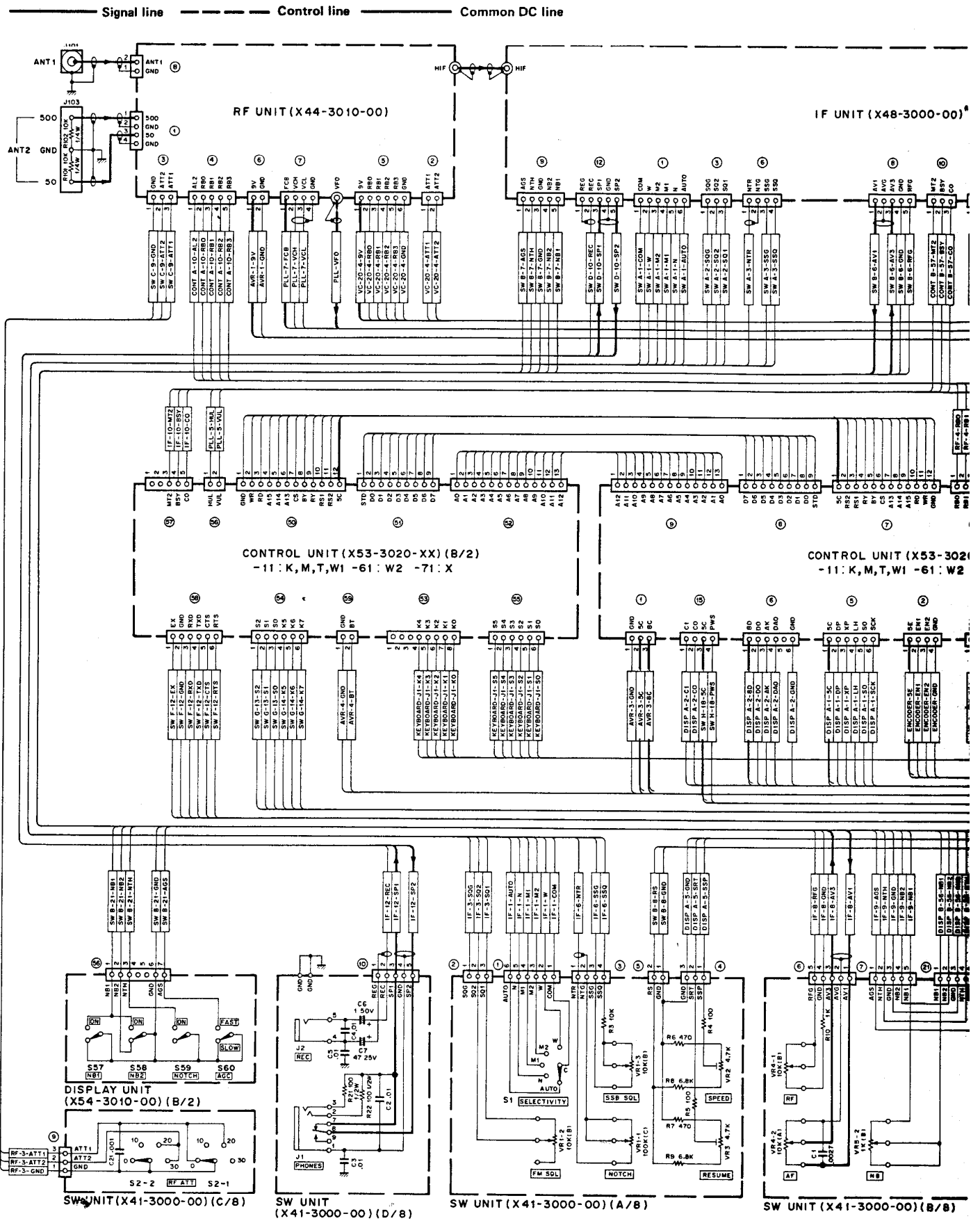

**CAUTION :** For continued safety, replace safety critical components only with manufacturer's recommended parts (refer to parts list).  
 ▲ indicates safety critical components. To reduce the risk of electric shock, leakage current or resistance measurement should be performed.

# SCHEMATIC DIAGRAM

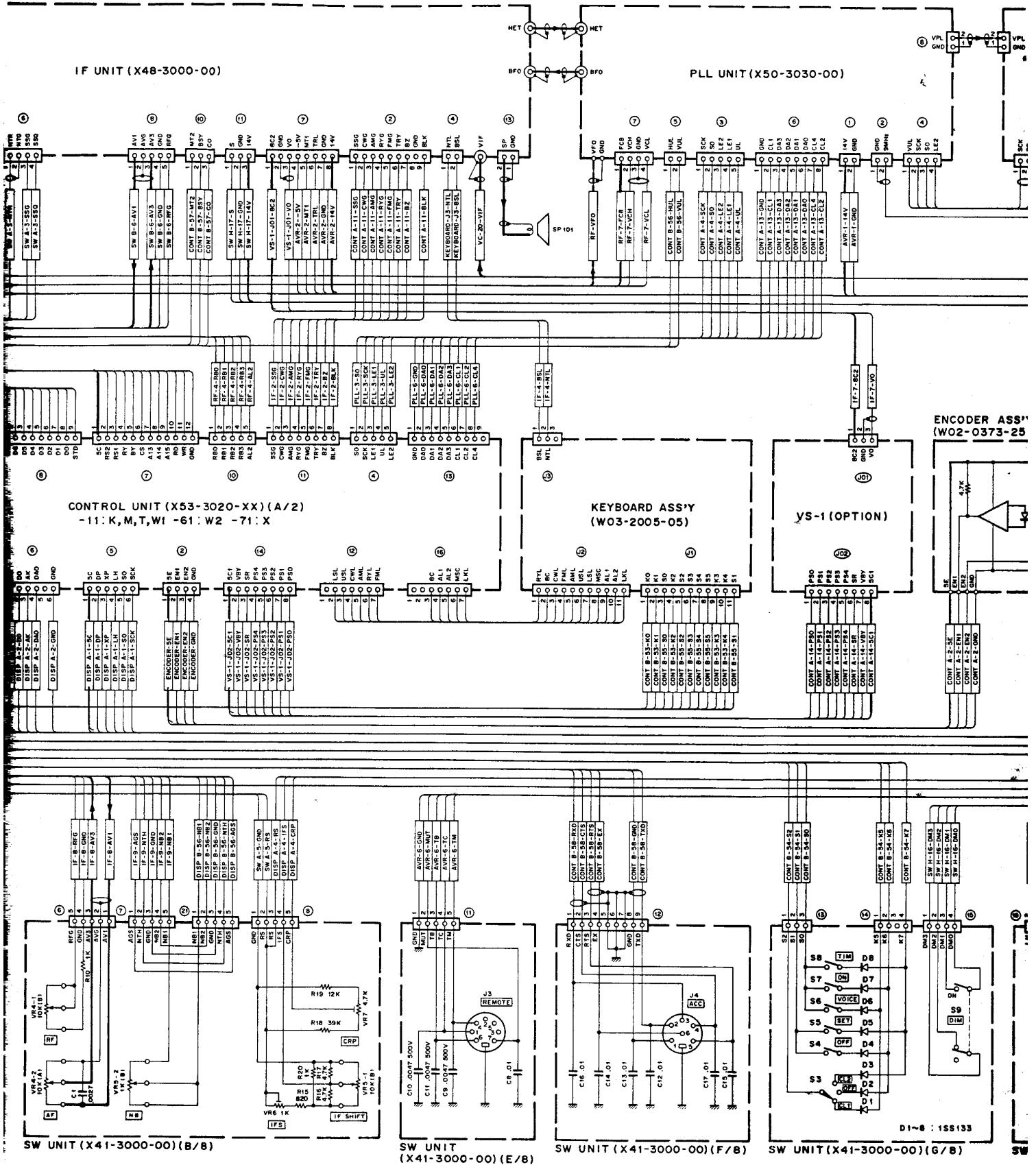

parts list).

## DISPLAY UNIT (X54-3010-00) (A/2)

VC-20 OPTION)

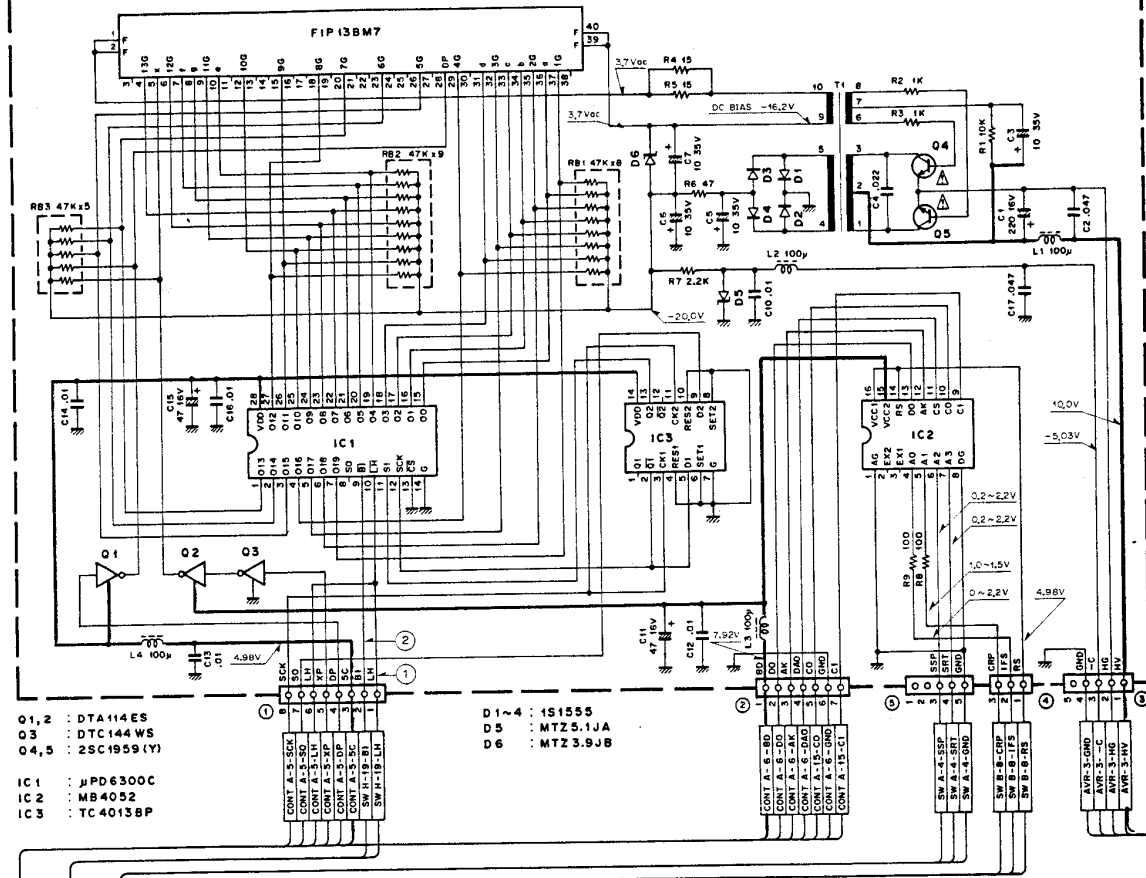
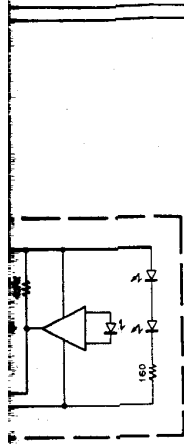
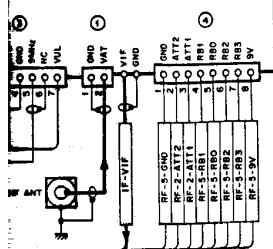

- O1, 2 : DTA114ES
- O3 : DTC144WS
- O4, 5 : 2SC1959(Y)
- IC1 : µPD6300C
- IC2 : MB4052
- IC3 : TC4013BP

- D1-4 : 1S1555
- D5 : MTZ5.1JA
- D6 : MTZ3.9JB

## AVR UNIT (X43-3000-00)

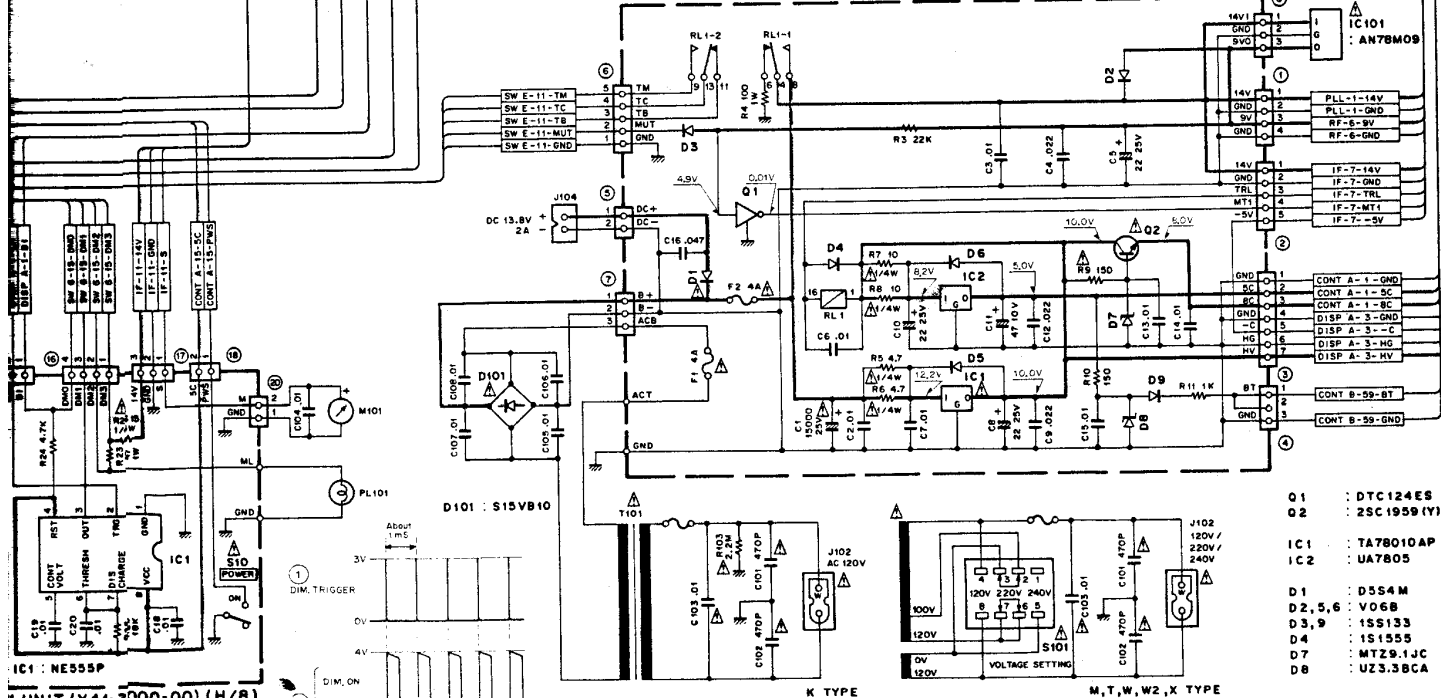

- O1 : DTC124ES
- O2 : 2SC1959(Y)
- IC1 : TA7810AP
- IC2 : UA7805

- D1 : D5S4M
- D2, 5, 6 : VOG8
- D3, 9 : 1S133
- D4 : 1S1555
- D7 : MTZ9.1JC
- D8 : WZ3.3BCA

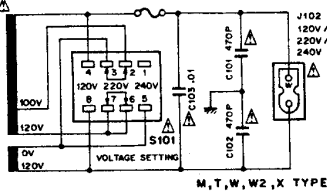
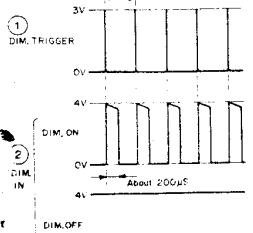

## TERMINAL FUNCTION

Terminal			Terminal Function	
No.	Name	I/O		
<b>SWITCH UNIT (X41-3000-00) (A/8)</b>				
①	1	COM	Filter select SW Common	
	2	W	Filter select SW W	
	3	M2	Filter select SW M2	
	4	M1	Filter select SW M1	
	5	N	Filter select SW N	
	6	AUTO	Filter select SW AUTO	
②	1	SOQ	GND	
	2	SQ2	} SQL VR (FM)	
	3	SQ1		
③	1	NTR	NOTCH VR	
	2	NTG	GND	
	3	SSG	GND	
	4	SSQ	SQL VR (SSB)	
④	1	SSP	Voltage terminal for scan speed setting.	
	2	SRT	Voltage terminal for resume time setting.	
	3	G	GND	
⑤	1	G	GND	
	2	RS	Power supply (+ 5V) for scan speed, resume time setting.	
<b>SWITCH UNIT (X41-3000-00) (B/8)</b>				
⑥	1	AV1	AF GAIN VR	
	2	AVG	AF Line GND	
	3	AV3	AF GAIN VR	
	4	GND	GND	
	5	RFG	RF GAIN VR	
⑦	1	AGS	AGC SLOW/FAST select SW. AGC FAST : GND	
	2	NTH	NOTCH SW, NOTCH ON : GND	
	3	GND	GND	
	4	NB2	Noise Blanker 2 SW. NB OFF : GND	
	5	NB1	Noise Blanker 1 SW. A voltage changes at VR5 when NB1 or NB2 SW ON.	
⑧	1	G	GND	
	2	RS	} Power supply (+ 5V) for carrier point, IF shift setting.	
	3	RS		
	4	IFS	Voltage terminal for IF shift setting (approx. 1.1V at center).	
	5	CRP	Voltage terminal for carrier point setting.	
<b>SWITCH UNIT (X41-3000-00) (C/8)</b>				
⑨	1	G	GND	
	2	ATT2	} RF ATT SW	
	3	ATT1		
<b>SWITCH UNIT (X41-3000-00) (D/8)</b>				
⑩	1	REG	Audio input for REC terminal	
	2	REC	Audio input for REC terminal	
	3	SP1	Audio output for PHONE terminal	
	4	G	GND	
	5	SP2	Audio input from PHONE terminal	
<b>SWITCH UNIT (X41-3000-00) (E/8)</b>				
⑪	1	GND	GND	
	2	MUT	Muting terminal (ON : GND)	
	3	TB	} POW ON : TC with TM connect	
	4	TC		
	5	TM	} STBY, POW OFF : TB with TC connect (for REMOTE)	
<b>SWITCH UNIT (X41-3000-00) (F/8)</b>				
⑫	1	RXD	RX data	
	2	CTS	Clear to SEND	
	3	RTS	Request to SEND	
	4	EX	Not used	
	5	GND	} ACC	
	6	GND		
	7	GND		
	8	G		Control unit GND
	9	TXD		TX data

Terminal			Terminal Function
No.	Name	I/O	
<b>SWITCH UNIT (X41-3000-00) (G/8)</b>			
⑬	1	S2	CL1/CL2 select CL1 ON : K5 with S2 connect CL1 OFF : K6 with S2 connect
	2	S1	CL2 ON : K7 with S2 connect
	3	S0	OFF TIME : S1 with K6 connect, TIME SET : S1 with K7 connect, VOICE : S0 with K5 connect, TIMER : S0 with K7 connect, ON TIME : S0 with K6 connect
⑭	1	K5	VOICE and CL1 terminal VOICE : K5 with S0 connect, CL1 : K5 with S2 connect
	2	K6	ON TIME, OFF TIME, CL terminal ON TIME : K6 with S0 connect, OFF TIME : K6 with S1 connect, CL OFF : K6 with S2 connect
	3	NC	Not connected
	4	K7	TIME SET, TIMER, CL2 terminal TIME SET : K7 with S1 connect, TIMER : K7 with S0 connect, CL2 : K7 with S2 connect
⑮	1	DM3	} DIM SW terminals DIM OFF : DM3 with DM2 connect } DIM SW terminals DIM ON : DM0 with DM1 connect
	2	DM2	
	3	DM1	
	4	O	
<b>SWITCH UNIT (X41-3000-00) (H/8)</b>			
⑯	1	DM3	} DIM SW terminals DIM OFF : DM3 with DM2 connect } DIM SW terminals DIM ON : DM1 with DM0 connect
	2	DM2	
	3	DM1	
	4	DM0	
⑰	1	M	S meter signal input
	2	G	GND
	3	14V	Power supply (+ 14V) for meter lamp
⑱	1	PWS	POW SW (POW ON : GND)
	2	5C	Power supply (+ 5V) for IC1
⑲	1	BI	DIM output terminal
	2	LH	DIM trigger pulse terminal
⑳	1	G	GND
	2	M	O S meter signal output terminal
㉑	1	NB1	Noise blanker 1 SW NB1 or NB2 ON : GND
	2	NB2	Noise blanker 2 SW NB2 OFF : GND
	3	GND	GND
	4	NTH	NOTCH SW NOTCH ON : GND
	5	AGS	AGC SLOW/FAST select SW AGC FAST : GN
		ML	Power supply output for Meter lamp
		G	GND
<b>AVR UNIT (X43-3000-00)</b>			
①	1	14V	Power supply (+ 14V) for PLL unit
	2	GND	GND
	3	9V	Power supply (+ 9V) for RF unit
	4	GND	GND
②	1	14V	+ 14V for IF unit
	2	GND	GND
	3	TRL	RL1 control terminal (POW ON : GND)
	4	MT1	MUTE signal (MUTE ON : "H")
	5	-5V	-5V for IF unit
③	1	GND	GND
	2	5C	+ 5V for Control unit
	3	8C	+ 8V for Control unit
	4	GND	GND
	5	-C	-5V from Display unit
	6	HG	GND
	7	HC	+ 10V for Display unit

Terminal		
No.	Name	Function
④	1	RT
	2	BT
	3	GND
⑤	1	+
	2	-
⑥	1	GND
	2	MUT
	3	TB
	4	TC
	5	TM
⑦	1	ACB
	2	B-
	3	B+
⑧	1	14VI
	2	GND
	3	9VO
		ATC
①	1	500
	2	GND
	3	50
	4	GND
②	1	ATT1
	2	ATT2
③	1	GND
	2	ATT2
	3	ATT1
④	1	AL2
	2	RB0
	3	RB1
	4	RB2
	5	RB3
⑤	1	9V
	2	RB0
	3	RB1
	4	RB2
	5	RB3
⑥	1	9V
	2	GND
⑦	1	FCB
	2	VCH
	3	VCL
	4	GND
⑧	1	GND
	2	ATT1
		HIF
		VFO
		MKR
①	1	COM
	2	W
	3	M2
	4	M1
	5	N
	6	AUTO

## TERMINAL FUNCTION

Terminal				Terminal Function
No.	Name	I/O		
④	1	RT	O	Lithium battery charge terminal to Control unit
	2	BT	O	
	3	GND	-	
⑤	1	+	I	DC power supply input
	2	-	-	
⑥	1	GND	-	GND
	2	MUT	I	
	3	TB	O	
	4	TC	O	
	5	TM	O	
				} For REMOTE
POW OFF : TB with TC connect				
POW ON : TC with TM connect				
⑦	1	ACB	O	AC power supply, 2nd voltage terminal
	2	B-	-	
	3	B+	I	
⑧	1	14VI	O	+ 14V for IC101
	2	GND	-	
	3	9VO	I	
		ATC	I	AC power supply, 2nd voltage terminal
<b>RF UNIT (X44-3010-00)</b>				
①	1	500	I	From ANT2 terminal
	2	GND	-	
	3	50	I	
	4	GND	-	
②	1	ATT1	I	ATT SW data 0, 20dB : "H"
	2	ATT2	I	
③	1	GND	-	GND
	2	ATT2	I	
	3	ATT1	I	
④	1	AL2	I	ANT 1/2 select
	2	RB0	I	
	3	RB1	I	
	4	RB2	I	
	5	RB3	I	
				} B.P.F. band data
⑤	1	9V	O	+ 9V for converter unit
	2	RB0	O	
	3	RB1	O	
	4	RB2	O	
	5	RB3	O	
	6	GND	-	
				} B.P.F. band data
⑥	1	9V	I	+ 9V
	2	GND	-	
⑦	1	FCB	O	+ 9V for PLL unit
	2	VCH	I	
	3	VCL	I	
	4	GND	-	
				} Main VCO select signal
⑧	1	GND	-	GND
	2	ATT1	I	
		HIF	O	Reception 1st IF (58.1125MHz)
		VFO	O	VCO output to PLL unit
		MKR	I	Marker signal input
<b>IF UNIT (X48-3000-00)</b>				
①	1	COM	O	SELECTIVITY SW Common
	2	W	I	
	3	M2	I	
	4	M1	I	
	5	N	I	
	6	AUTO	I	

Terminal				Terminal Function
No.	Name	I/O		
②	1	SSG	I	USB, LSB mode : "L", other modes : OPEN
	2	CWG	I	
	3	AMG	I	
	4	RYG	I	
	5	FMG	I	
	6	TRY	I	
	7	BZ	I	
	8	GND	-	
	9	BLK	I	
				} FM Squelch VR
③	1	SQG		
	2	SQ2		
	3	SQ1		
④	1	NTL	O	NOTCH LED lit on current absorption
	2	BSL	O	
⑥	1	NTR		} NOTCH VR
	2	NTG		
	3	SSG		
	4	SSQ		
⑦	1	8C2	O	Power supply (+ 9V) for VS-1
	2	G	-	
	3	VO	I	
	4	-5V	I	
	5	MT1	I	
				} VS-1 voice synthesizer input
				} -5V for block bias
				} External mute signal, normally, : "L", Muting : "H"
⑧	6	TRL	O	TIMER relay control, set at "L" = Active
	7	G	-	
⑧	8	14V	I	From power supply rectifier output (not from AVR unit)
⑧	1	AV1	O	} AF GAIN VR
	2	AVG	-	
	3	AV3	I	
	4	G	-	
	5	RFG	-	
				} RF GAIN VR
⑨	1	AGS	I	AGC SW, SLOW : OPEN, FAST : GND
	2	NTH	I	
	3	G	-	
	4	NB2	I	
	5	NB1	I	
				} NB2 SW OFF : GND, ON : OPEN
				} NB1 SW via NB LEVEL VR
⑩	1	MT2	O	Send external muting signal to microprocessor
	2	BSY	O	
	3	CO	O	
				} Muting : "L"
				} Send BUSY signal to microprocessor
				} BUSY : "L" (Center decision is added in AM, FM mode.)
				} SCAN TO/CO select, normally (GND) : TO, when W64 cut : OPEN, CO
⑪	1	S	O	S meter output
	2	G	-	
	3	14V	O	
				} + 14V for pilot lamp
⑫	1	REG	-	REC OUT output
	2	REC	O	
	3	SP1	O	
	4	GND	-	
	5	SP2	I	
				} AF power amp. output
				} AF power amp. output, switched by PHONES
⑬	1	G		Internal speaker output
	2	SP	O	
J5		EXT.SP	O	External speaker output
		VIF	I	
		HIF	I	
		HET	O	
		BFO	I	
				} Reception IF signal from VC-20 (58.1125MHz)
				} Reception IF signal from HF band (58.1125MHz)
				} 2nd LOCAL OSC signal (49.2825MHz)
				} SSB demodulation carrier (8.83MHz)

## TERMINAL FUNCTION

Terminal			Terminal Function
No.	Name	I/O	
<b>PLL UNIT (X50-3030-00)</b>			
①	1	14V	I +14V
	2	GND	- GND
②	1	GND	-
	2	9MHz	O 9MHz for VC-20
③	1	SCK	I Clock signal for serial PLL data
	2	SO	I Serial PLL data signal
	3	LE2	I VC-20, IC101 (PLL5) latch signal
	4	LE1	I IC12 (PLL3) latch signal
	5	UL	O Unlock signal
④	1	VUL	I VC-20 Unlock signal
	2	SCK	O VC-20 Clock signal from PLL data
	3	SO	O VC-20 PLL data signal
	4	LE2	O VC-20 PLL data latch signal for IC101
⑤	1	VUL	O VC-20 Unlock signal
	2	HUL	O HF band last PLL unlock signal
⑥	1	GND	- GND
	2	CL1	I IC2 (PLL1) clock signal
	3	DA3	I } MN6147/C PLL data signal
	4	DA2	I }
	5	DA1	I }
	6	DA0	I }
	7	CL4	I IC14 (PLL4) clock signal
	8	CL2	I IC8 (PLL2) latch enable signal
⑦	1	FCB	I Power supply line for IC13
	2	VCH	O RF unit VCO4 control voltage
	3	VCL	O RF unit VCO1~3 control voltage
	4	G	- GND
⑧	1	G	- GND
	2	VPL	O PLL low-figures signal for VC-20 (96.1125~97.11249MHz or 95.1125~96.11249MHz)
		HET	I HET signal (49.2825MHz)
		BFO	O BFO signal (8.83MHz)
		VFO	I RF unit VCO1~4 output signal
		MKR	O 500kHz marker output signal
<b>CONTORL UNIT (X53-3020-00) (A/2)</b>			
①	1	GND	- Power supply GND
	2	5C	I Power supply +5V
	3	8C	I Power supply +8V
②	1	5E	O Encoder +5V
	2	EN1	I Encoder count pulse 1
	3	EN2	I Encoder count pulse 2
	4	GND	- GND
③			Not used
④	1	SO	O Serial data output (PLL data)
	2	SCK	O Serial clock output (PLL data)
	3	LE1	O PLL3 latch enable (Active: "H")
	4	UL	I Low-figures unlock signal (Lock: "H")
	5	LE2	O PLL5 latch enable (Active: "H", Option VHF Converter)
⑤	1	5C	O Display +5V
	2	DP	O Display "decimal point" signal (Lit ON: "H")
	3	XP	O Display "Red letters" signal (Lit ON: "L")
	4	LH	O Display latch enable output (Active: "L")
	5	SO	O Serial data output for display
	6	SCK	O Serial clock output for display
⑥	1	8D	O Display +8V
	2	DO	I A/D converter, data converter input
	3	AK	O A/D converter, clock converter output
	4	DA0	O A/D converter, reset signal
	5	-	- Not used
	6	GND	- GND

Terminal			Terminal Function
No.	Name	I/O	
⑦	1	5C	O Control unit (B/2) +5V
	2	RS2	O I/O port reset signal (Active: "H")
	3	RS1	O System reset signal (Active: "L")
	4	RY	I External control character acknowledge signal (Option)
	5	BY	O VS-1 Voice-synthesizer BUSY signal (BUSY: "H") (Option)
	6	CS	I IC2 I/O port select signal (Active: "L")
	7	A13	O Microprocessor address signal
	8	A14	O Microprocessor address signal
	9	A15	O Microprocessor address signal
	10	RD	O Microprocessor control signal
	11	WR	O Microprocessor control signal
	12	GND	- GND
⑧	1	D7	I/O } Microprocessor data bus
	2	D6	I/O }
	3	D5	I/O }
	4	D4	I/O }
	5	D3	I/O }
	6	D2	I/O }
	7	D1	I/O }
	8	D0	I/O }
	9	STD	I Clock, clock-count interrupting signal (64Hz, duty 50%)
⑨	1	A12	O } Microprocessor address signal
	2	A11	O }
	3	A10	O }
	4	A9	O }
	5	A8	O }
	6	A7	O }
	7	A6	O }
	8	A5	O }
	9	A4	O }
	10	A3	O }
	11	A2	O }
	12	A1	O }
	13	A0	O }
⑩	1	RB0	O } Band information signal
	2	RB1	O }
	3	RB2	O }
	4	RB3	O }
	5	AL2	O ANT 1/2 select signal (ANT2: "L")
⑪	1	SSG	O } Mode select signal (LSB or USB: "L")
	2	CWG	O } (CW: "L")
	3	AMG	O } (AM: "L")
	4	RYG	O } (FSK: "L")
	5	FMG	O } (FM: "L")
	6	TRY	O TIMER relay signal (POW ON: "L")
	7	BZ	O Buzzer signal
	8	BLK	O Blanking signal (Blanking: "H")
⑫	1	-	- Not used
	2	LSL	O } Mode LED output (LSB: "L")
	3	USL	O } (USB: "L")
	4	CWL	O } (CW: "L")
	5	AML	O } (AM: "L")
	6	RYL	O } (FSK: "L")
	7	FML	O } (FM: "L")

## TERMINAL FUNCTION

Terminal			Terminal Function	Terminal			Terminal Function				
No.	Name	I/O		No.	Name	I/O					
⑬	1	GND	—	GND	⑫	1	A0	I	Microprocessor address bus		
	2	DA0	O	Data output for MN6147		2	A1	I			
	3	DA1	O			3	A2	I			
	4	DA2	O			4	A3	I			
	5	DA3	O			5	A4	I			
	6	CL1	O	PLL data		6	A5	I			
	7	CL2	O			7	A6	I			
	8	CL4	O			8	A7	I			
	9	—	—	Not used		9	A8	I			
⑭	1	5C1	O	+ 5V for VS-1		10	A9	I			
	2	VBY	I	VS-1 Voice-synthesizer BUSY signal		11	A10	I			
	3	SR	O	VS-1 Voice-synthesizer START signal		12	A11	I			
	4	PS4	O	VS-1 Voice data output		13	A12	I			
	5	PS3	O								
	6	PS2	O								
	7	PS1	O								
	8	PS0	O								
⑮	1	C1	O	A/D converter channel select signal	⑬	1	—	—	Not used		
	2	C0	O								
	3	5C	O	+ 5V for Dimmer		2	—	—	Not used		
	4	PWS	I	Power SW input (POW SW ON : "L", OFF : "H")		3	—	—	Not used		
⑯	1	—	—	Not-used		⑭	4	K4	I	Key scan, column input	
	2	—	—	Not used			5	K3	I		
	3	8C	O	Keyboard ass'y, LED drive 8V			6	K2	I		
	4	AL1	O	ANT1 LED (Lit ON : "L")			7	K1	I		
	5	AL2	O	ANT2 LED (Lit ON : "L")	8	K0	I				
	6	MSC	O	MSR LED (Lit ON : "L")	⑮	1	S2	O	Key scan		
	7	LKL	O	LOCK LED (Lit ON : "L")		2	S1	O			
⑰	<b>CONTROL UNIT (X53-3020-00) (B/2)</b>			⑮		3	S0	O			
	1	GND	—			GND	4	K5		I	Key scan, column input
	2	WR	I			Microprocessor control signal	5	K6		I	
	3	RD	I								
	4	A15	I		Microprocessor address signal	6	K7	I			
	5	A14	I								
6	A13	I									
7	CS	O	IC2 I/O port select signal (Active : "L")	⑯	1	S5	O	Key scan			
8	BY	I	VS-1 Voice-synthesizer BUSY signal (BUSY : "H") (Option)		2	S4	O				
9	RY	O	External control character acknowledge signal (Option)		3	S3	O				
10	RS1	I	System reset signal (Active : "L")		4	S2	O				
11	RS2	I	I/O port reset signal (Active : "H")		5	S1	O				
12	5C	I	Control unit (B/2), + 5V		6	S0	O				
⑱	1	STD	O	Clock, clock-count, interrupting signal (64kHz, duty 50%, open drain output)	⑰	1	HUL	I	HF PLL UL signal (LOCK : "L", UNLOCK : "H")		
	2	D0	I/O	Microprocessor data bus		2	VUL	I	VHF PLL UL signal (LOCK : "L", UNLOCK : "H") (Option)		
	3	D1	I/O								
	4	D2	I/O								
	5	D3	I/O								
	6	D4	I/O								
	7	D5	I/O								
	8	D6	I/O								
	9	D7	I/O								
⑲	<b>CONTROL UNIT (X53-3020-00) (B/2)</b>				⑰	⑱	1	MT2	I	External MUTE signal (MUTE : "L", NONE : "H")	
	1	GND	—	GND			4	BSY	I	Center STOP BUSY signal (signal BUSY : "L", NONE : "H")	
	2	WR	I	Microprocessor control signal			5	CO	I	BUSY stop TO/CO select (TO : "L", CO : "H")	
	3	RD	I								
	4	A15	I	Microprocessor address signal			⑳	1	EX	—	Not used
	5	A14	I								
	6	A13	I								
	7	CS	O	IC2 I/O port select signal (Active : "L")		2		G	—	Control unit, ground level signal	
	8	BY	I	VS-1 Voice-synthesizer BUSY signal (BUSY : "H") (Option)		3		RXD	I	RX data input for external control	
	9	RY	O	External control character acknowledge signal (Option)		4		TXD	O	TX data output for external control	
	10	RS1	I	System reset signal (Active : "L")		5	CTS	I	External control BUSY control, clear to SEND		
	11	RS2	I	I/O port reset signal (Active : "H")		6	RTS	O	External control BUSY control, request to SEND		
12	5C	I	Control unit (B/2), + 5V	㉑	1	GND	—	Ground for lithium battery charge			
<b>CONTROL UNIT (X53-3020-00) (B/2)</b>			2		BT	I	Lithium battery charge voltage input				
<b>CONTROL UNIT (X53-3020-00) (B/2)</b>			<b>DISPLAY UNIT (X54-3010-00) (A/2)</b>			㉒	1	LH	O	Dimmer control trigger signal	
1	GND	—	GND	2	BI		I	Dimmer control input			
2	WR	I	Microprocessor control signal	3	5C		I	+ 5V for Display unit			
3	RD	I									
4	A15	I	Microprocessor address signal	4	DP		I	Display "decimal point" signal (Lit ON : "H")			
5	A14	I									
6	A13	I									
7	CS	O	IC2 I/O port select signal (Active : "L")	5	XP		I	Display "red letters" signal (Lit ON : "L")			
8	BY	I	VS-1 Voice-synthesizer BUSY signal (BUSY : "H") (Option)	6	LH	I	Display latch enable input (Active "L")				
9	RY	O	External control character acknowledge signal (Option)	7	SO	I	Serial data input for display				
10	RS1	I	System reset signal (Active : "L")	8	SCK	I	Serial clock input for display				
11	RS2	I	I/O port reset signal (Active : "H")	<b>DISPLAY UNIT (X54-3010-00) (A/2)</b>							
12	5C	I	Control unit (B/2), + 5V								

## TERMINAL FUNCTION/CRYSTAL FILTER

Terminal			Terminal Function	
No.	Name	I/O		
②	1	8D	I	+ 8V for Display unit
	2	D0	O	A/D converter data output
	3	AK	I	A/D converter clock input
	4	DA0	I	A/D converter reset signal
	5	C0	I	A/D converter channel select signal
	6	GND	-	GND
	7	C1	I	A/D converter channel select signal
③	1	HV	I	DC-DC converter input for display tube + 10V
	2	HG	I	DC-DC converter input for display tube GND
	3	-C	O	-5V output
	4	GND	-	GND
	5			Not used

Terminal			Terminal Function	
No.	Name	I/O		
④	1	RS	O	Standard voltage for analog input
	2	IFS	I	Analog input, IF shift
	3	CRP	I	Analog input, carrier point correction
⑤	1			Not used
	2			Not used
	3	SSP	I	Analog input, scan speed
	4	SRT	I	Analog input, scan resume time
	5	GND	-	GND
<b>DISPLAY UNIT (X54-3010-00) (B/2)</b>				
①	1	NB1	O	NB1 SW ON : "L"
	2	NB2	O	NB2 SW ON : OPEN
	3	NTH	O	NOTCH SW ON : "L"
	4			Not used
	5			Not used
	6	GND	-	GND
	7	AGS	O	FAST : "L"

### Option filters

Item	Rating
Nominal center freq' (fo)	8830kHz
Center freq' deviation	Within $\pm 250\text{Hz}$ at 6dB
Pass bandwidth	$\pm 3.0\text{kHz}$ or more at 6dB
Attenuation bandwidth	$\pm 6.0\text{kHz}$ or less at 60dB $\pm 1.0\text{kHz}$ or less at 80dB
Ripple	2dB or less
Insertion loss	3dB $\pm$ 2dB
Guaranteed attenuation	80dB or more at $f_o \pm 10\text{kHz} \sim \pm 1\text{MHz}$
Input/output impedance	600 $\Omega$ /15pF

MCF (L71-0237-05) YK-88A-1

Item	Rating
Center freq' (fo)	8830.7kHz
Center freq' deviation	Within $\pm 150\text{Hz}$ at 6dB
Pass bandwidth	$\pm 250\text{Hz}$ or more at 6dB
Attenuation bandwidth	$\pm 900\text{Hz}$ or less at 60dB
Ripple	2dB or less
Minimum loss	6dB $\pm$ 2dB
Guaranteed attenuation	80dB or more at $f_o \pm 2\text{kHz} \sim \pm 1\text{MHz}$
Impedance	600 $\Omega$ /15pF

CW crystal filter (L71-0211-05) YK-88C

Item	Rating
Center freq' (fo)	8830kHz
Center freq' deviation	Within $\pm 150\text{Hz}$ at 6dB
Pass bandwidth	$\pm 900\text{Hz}$ or more at 6dB
Attenuation bandwidth	$\pm 1800\text{Hz}$ or less at 60dB
Guaranteed attenuation	80dB or more at $f_o \pm 2.5\text{kHz} \sim \pm 1\text{MHz}$
Ripple	2dB or less
Insertion loss	3dB $\pm$ 2dB
Impedance	600 $\Omega$ /15pF

SSB crystal filter (L71-0220-05) YK-88SN

Item	Rating
Nominal center freq' (fo)	8830.7kHz
Center freq' deviation	Within $\pm 150\text{Hz}$ at 6dB/25°C
Pass bandwidth	$\pm 125\text{Hz}$ or more at 6dB
Attenuation bandwidth	$\pm 600\text{Hz}$ or less at 60dB
Guaranteed attenuation	80dB or more at $f_o \pm 2\text{kHz} \sim \pm 1\text{MHz}$
Ripple	2dB or less
Insertion loss	8dB $\pm$ 2dB
Impedance	600 $\Omega$ /15pF

CW crystal filter (L71-0221-05) YK-88N

OCK : "H")

Y : "L",

CO : "H")

to SEND  
st to SEND

↓ : "H")  
'L")  
')

## VS-1 (VOICE SYNTHESIZER)

VS-1 SCHEMATIC DIAGRAM

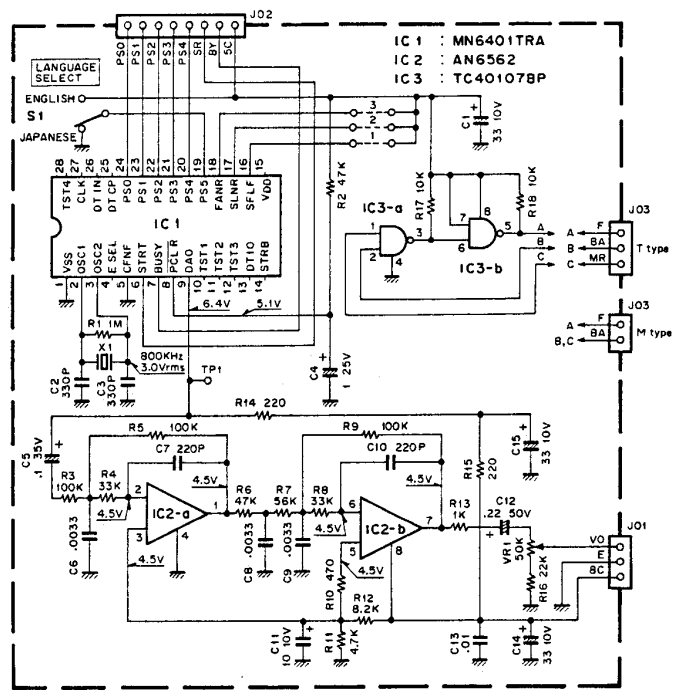

VS-1 PARTS LIST

Part No.	Remarks	Description	Ref. No.
B50-4035-00	N	Instruction manual	
CK45B1H331K	C	330P x 2	C2,3
CE04CW1A330M	E	33 10V	C1,14,15
CE04CW1A100M	E	10 10V	C11
CE04CW1HR22M	E	0.22 50V	C12
CK45B1H221K	C	220P x 2	C7,10
CQ92M1H332K	ML	0.0033 x 3	C6,8,9
CS15E1E010M	T	1 25V	C4
CS15E1V0R1M	T	0.1 35V	C5
C91-0131-05	C	0.01 (SP)	C13
E40-0273-05	Δ	Mini connector 2P	M J03
E40-0373-05	Δ	Mini connector 3P	M J01
E40-0373-05	Δ	Mini connector x 2 3P	T J03, J01
E40-0873-05	Δ	Mini connector 8P	J02
H01-4481-03	NΔ	Packing carton (inside)	M
H01-4501-03	NΔ	Packing carton (inside)	T
H25-0029-04		Protective bag x 2	
L78-0006-05	N	Ceramic OSC	X1
N89-3006-46		Tapping screw x 4	
R12-4408-05		Trim. pot. 50kΩ	VR1
S31-1411-05	N	Slide switch	S1
AN6562	N	IC	IC2
MN6401TRA	N	IC	IC1
TC40107BP	N	IC	IC3

TALK SPEED SELECTION

Speed is factory set at "standard" talk speed. Three different speeds can be selected.

Note: When placing the jumper, solder carefully.

Speed	Std. speed	30% more than Std.	60% more than Std.
Jumper place			
1	X	X	O
2	X	X	O
3	X	O	X

Symbol O, denotes the place in which a jumper wire is placed.

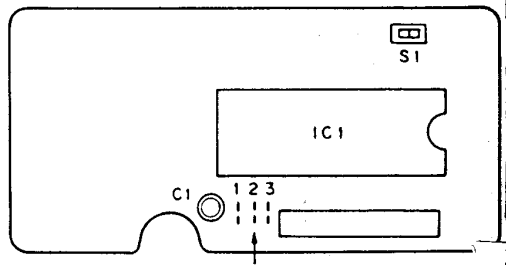

New parts Ref. No.

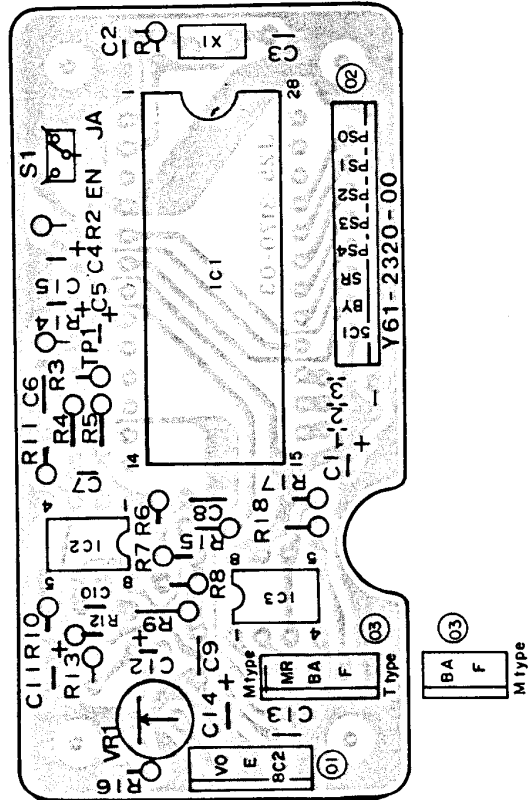

# R-5000

## MB-430 (MOBILE MOUNT)/SP-430 (SPEAKER)

### MB-430 OUTSIDE VIEW

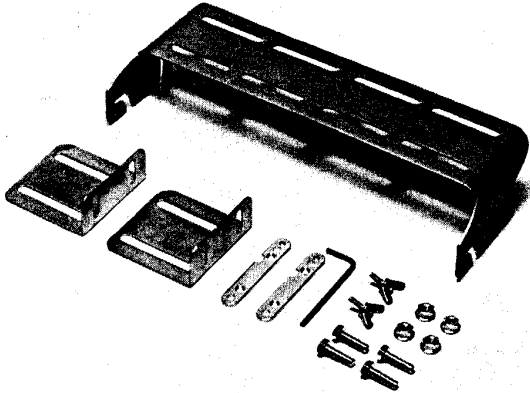

### MB-430 PARTS LIST

N : New parts

Part No.	Re- marks	Description	Ref. No.
A13-0635-03	N	Angle	
B50-4016-00	N	Instruction manual	
H01-4453-13	N	Packing control (inside) <b>M</b>	
H01-4454-13	N	Packing control (inside) <b>T</b>	
H25-0077-04		Protective bag	
H25-0098-04		Protective bag 150 x 480	
J30-0521-04	N	Spacer x 2	
N09-0007-05		Wing bolt x 5	
N09-0008-04		Hex. screw x 6	
N14-0009-04		Nut x 6	
N15-1060-46		Flat washer x 6	
N16-0060-46		Spring washer x 6	
N32-3006-46		Flat screw x 4	
N99-0309-04	N	Hex. head screw x 6	
W01-0401-04		Hex. wrench	

### SP-430 SPECIFICATIONS

<b>SPEAKER SIZE</b>	3"
<b>RATED INPUT</b>	1.0 watts
<b>IMPEDANCE</b>	8 ohms
<b>FREQUENCY RESPONSE</b>	300 Hz to 5 kHz
<b>DIMENSIONS</b>	4-7/8" wide x 3-3/4" high x 9-1/3" deep (excluding feet)
<b>WEIGHT</b>	3.1 lbs.

### SP-430 PARTS LIST

N : New parts

Part No.	Re- marks	Description	Ref. No.
A01-0942-03	N	Case (B)	
A01-0944-13	N	Case (A)	
A20-2468-03	N	Panel	<b>K,M</b>
A20-2469-03	N	Panel	<b>T</b>
A23-1431-04		Rear panel	
B04-0406-04	N	SP grill	
B07-0613-14		SP ring	
B39-0407-04		Spacer x 2	
B46-0404-00		Warranty card	<b>K</b>
B50-4026-10	N	Instruction manual	<b>K,M</b>
B50-4027-00	N	Instruction manual	<b>T</b>
E20-0208-04		Terminal plate	
E30-1629-15		SP cord	
G53-0507-04		Packing x 4	
H01-4468-14	N	Packing carton	<b>K,M</b>
H01-4469-04	N	Packing carton	<b>T</b>
H10-2513-02		Packing fixture (F)	
H10-2514-12		Packing fixture (R)	
H12-0445-04		Cushion	
H20-1407-03		Protective cover	
H25-0077-03		Protective bag Accessory	
J02-0323-05		Foot x 4	
J02-0409-04		Assistant foot	
J21-1144-14		SP mounting hardware x 2	
J21-2573-04		Foot mounting hardware x 2	
J61-0019-05		Vinyle tie	
N15-1030-46		Washer x 8	
N30-3008-46		Round screw x 4	
N35-3006-41		Bind screw x 12 Case	
N87-3006-46		Self tapping screw x 6	
N87-3008-46		Self tapping screw x 4	
T07-0224-05	N	Speaker	

## VC-20 (VHF CONVERTER)

### SPECIFICATIONS

**Frequency range**

108~174MHz

**Antenna impedance**

50Ω

**Power requirement/power consumption**

DC 9V, 300mA (supplies from R-5000.)

**Dimensions ( ) includes projection**

W 170(174) x H 25(27) x D 123(136)mm

**Weight**

550g

**Receive sensitivity**

Mode	Condition	Sensitivity
SSB, CW, FSK	S + N/N = 10dB	0.25μV or less
AM	30% Mod. S + N/N = 10dB	2μV or less
FM	12dB SINAD	0.5μV or less

**Squelch sensitivity**

Mode	Sensitivity
SSB, CW, FSK	2μV or less
AM	2μV or less
FM	0.32μV or less

**Spurious response**

1st IF : 80dB or more

Others : 50dB or more

**Frequency stability**

Within  $\pm 10 \times 10^{-6}$  ( $-10^{\circ}\text{C} \sim +50^{\circ}\text{C}$ )

**Frequency accuracy**

Within  $\pm 10 \times 10^{-6}$

**Note :** Circuit and ratings subject to change without notice due to developments in technology.

● **GENERAL**

The VC-20 is the VHF converter designed to be used exclusively with the R-5000 Shortwave Receiver.

The VC-20 allows expansion of the receiver frequency range to 108MHz thru 174MHz without altering the operation of the R-5000.

● **RF SECTION (X44-2030-00) (A/2)**

The signal applied from the antenna terminal is passed through the attenuator circuit and amplified by RF amplifiers consisting of Q1 thru Q4 : 3SK148R and Q5 thru Q8 : 2SK125-5. These RF amplifier circuits divide the frequencies from 108MHz to 174MHz in four distinct bands. Each band has its own amplifier. The bands are : 108MHz thru 123MHz (LL band); 123MHz to 138MHz (L band); 138MHz to 155MHz (H band); and 155MHz to 174MHz (HH band).

The signal then passes through the first IF trap. T22, and is applied to the first mixer Q9 and Q10 : 3SK74L. In the IF trap the signal is converted into the first IF frequency of 58.1125MHz by mixing the RF signal with the signal from the VCO (Voltage Controlled Oscillator) in the PLL unit. Q11 : 2SC2570A performs the task of mixing these two signals.

● **PLL SECTION (X44-3020-00) (B/2)**

The PLL section includes the PLL circuit and the Band data decoder circuit. The PLL circuit utilizes a single reference loop design, which uses the VPL signal of 95.1125MHz to 97.1125MHz from the R-5000 to enable the VCO to cover 166.1125MHz to 232.1125MHz in 10Hz step.

Actually the VPL signal varies in a series of 1MHz wide bands, between 95.1125MHz to 96.1125MHz and 96.1125MHz to 97.1125MHz. Either of these ranges is selected according to the actual receiver dial frequency.

# R-5000

## VC-20 (VHF CONVERTER)

BLOCK DIAGRAM

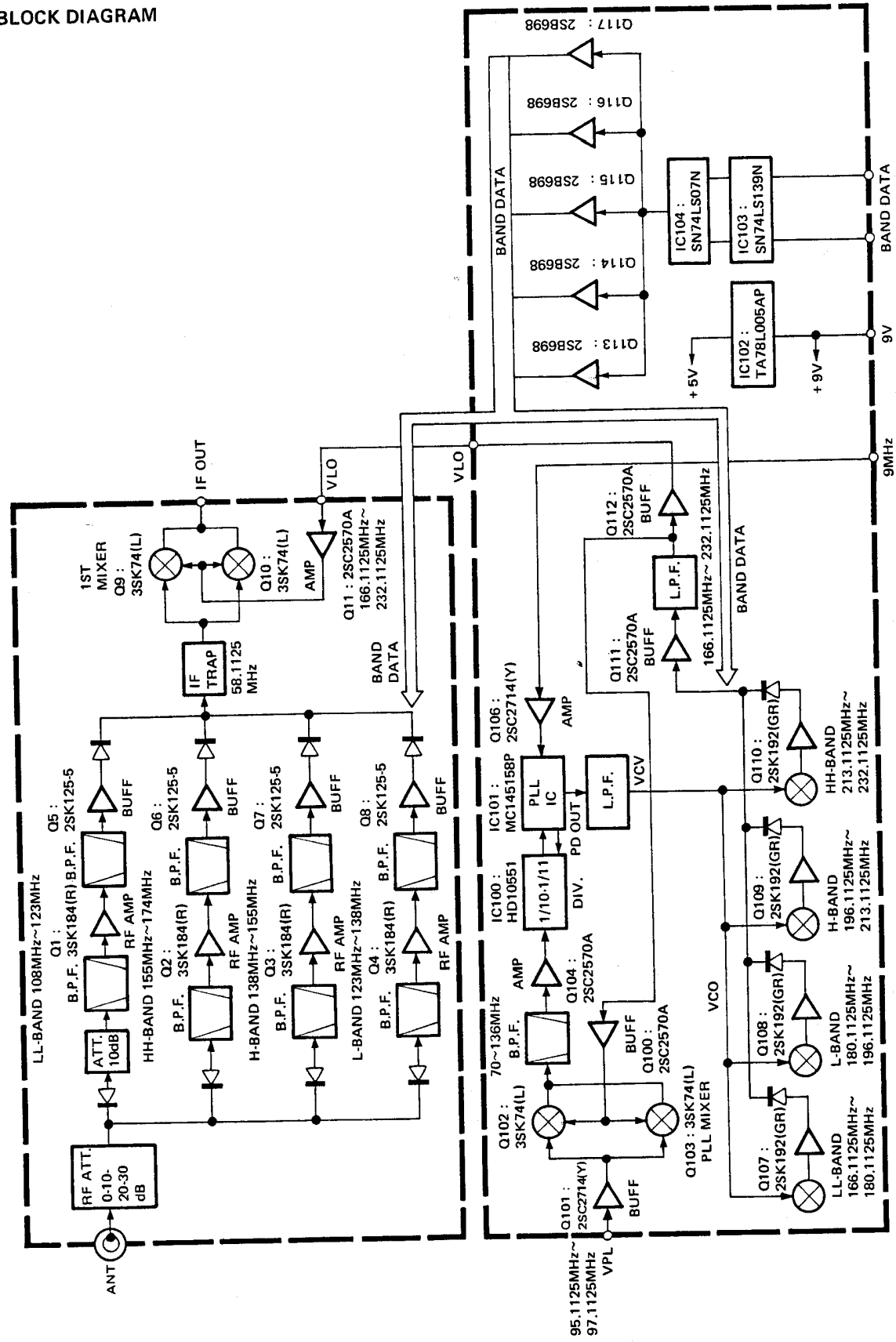

## VC-20 (VHF CONVERTER)

### TERMINAL FUNCTIONS

Terminal			Terminal Function
No.	Name	I/O	
①	1	GND	GND
	2	VAT	Antenna input
②	1	GND	GND
	2	VPL	OSC signal from PLL unit. 95.1125~97.1125MHz
③	1	CLK	Clock signal
	2	DAT	Data line
	3	LE2	Latch enable signal
	4	GND	GND for CLK, DAT
	5	9M	Standard 9MHz signal from PLL unit
	6	NC	GND for 9M
	7	VUL	VHF unlock signal UL : "H" (OPEN)
④	1	GND	GND
	2	AT2	20dB attenuator control
	3	AT1	10dB attenuator control
	4	RB1	} Band information from IF unit
	5	RB0	
	6	RB2	
	7	RB3	
	8	9V	+ 9V line from IF unit

### SEMICONDUCTOR

N : New parts

Item	Re- marks	Part No.
<b>Diode</b>		1S2588
		1S5133
		DAN401
		MA858
<b>Varicap</b>		1SV153
<b>Diode</b>		DAN202(K)
<b>Chip Diode</b>		
<b>Zener Diode</b>		MTZ3.3JA
		MTZ5.1JA
		MTZ7.5JA
<b>TR</b>		2SB698(E,F)
		2SC2570A
<b>Chip TR</b>		2SC2714(Y)

Item	Re- marks	Part No.
<b>Digital TR</b>		DTC124EK
<b>Chip FET</b>		3SK184(R)
<b>FET</b>		2SK125-5
		2SK192A(GR)*P
<b>IC</b>		3SK74(L)
		HD10551
		MC145158P
	N	SN74LS07N
		SN74LS139N
		TA78L005AP

**-5000**

# VC-20 (VHF CONVERTER)

## PARTS LIST

\* New Parts

Parts without Parts No. are not supplied.

Les articles non mentionnés dans le Parts No. ne sont pas fournis.

Telle ohne Parts No. werden nicht geliefert.

Ref. No.	Address	New Parts	Parts No.	Description	Desti- nation	Re- marks
参照番号	位置	新	部品番号	部品名 / 規格	仕向	備考
<b>VC-20</b>						
-		*	B40-3694-04	MODEL NAME PLATE	K1M1	
-		*	B40-3695-04	MODEL NAME PLATE	T1	
-			B42-2437-04	LABEL		
-			B46-0411-00	WARRANTY CARD	K1	
-		*	B50-8126-00	INSTRUCTION MANUAL	K1M1	
-		*	B50-8128-00	INSTRUNTION MANUAL	T1	
-		*	H01-8056-03	CARTON BOX	K1M1	
-		*	H01-8057-03	CARTON BOX	T1	
-		*	H03-2639-04	OUTER PACKING CASE	K1M1	
-		*	H03-2640-04	OUTER PACKING CASE	T1	
-			H12-1397-04	PACKING FIXTURE (UPPER)		
-			H12-1398-03	PACKING FIXTURE (LOWER)		
-			H25-0029-04	PROTECTION BAG (ACCESSORY)		
-			H25-0162-04	PROTECTION BAG (REALITY)		
-			J21-4210-04	MOUNTING HARDWARE		
-			J21-4211-04	MOUNTING HARDWARE		
-			N35-3004-41	BINDING HEAD MACHINE SCREW		
-			N87-3006-41	BRAZIER HEAD TAPTITE SCREW		
-		*	X44-3020-00	CONVERTER UNIT		
<b>CONVERTER UNIT (X44-3020-00)</b>						
C1 -4			CK73FB1H103K	CHIP C 0.010UF K		
C6			CK45F1H103Z	CERAMIC 0.010UF Z		
C7			CK73FB1H103K	CHIP C 0.010UF K		
C8			CC73FCH1H090D	CHIP C 9.0PF D		
C9			CC73FCH1H020C	CHIP C 2.0PF C		
C10			CC73FCH1H080D	CHIP C 8.0PF D		
C11 -13			CK73FB1H103K	CHIP C 0.010UF K		
C14			CC73FCH1H090D	CHIP C 9.0PF D		
C15			CC73FCH1H1R5C	CHIP C 1.5PF C		
C16			CC73FCH1H100D	CHIP C 10PF D		
C17			CC73FCH1H020C	CHIP C 2.0PF C		
C18			CC73FCH1H070D	CHIP C 7.0PF D		
C19 -21			CK73FB1H103K	CHIP C 0.010UF K		
C22			CC73FCH1H050C	CHIP C 5.0PF C		
C23			CC73FCH1H1R5C	CHIP C 1.5PF C		
C24			CC73FCH1H040C	CHIP C 4.0PF C		
C25 -27			CK73FB1H103K	CHIP C 0.010UF K		
C28			CC73FCH1H050C	CHIP C 5.0PF C		
C29			CC73FCH1H010C	CHIP C 1.0PF C		
C30			CC73FCH1H050C	CHIP C 5.0PF C		
C31			CC73FCH1H1R5C	CHIP C 1.5PF C		
C33 -35			CK73FB1H103K	CHIP C 0.010UF K		
C36			CC73FCH1H070D	CHIP C 7.0PF D		
C37			CC73FCH1H1R5C	CHIP C 1.5PF C		
C38			CC73FCH1H070D	CHIP C 7.0PF D		
C39 -41			CK73FB1H103K	CHIP C 0.010UF K		
C42			CC73FCH1H070D	CHIP C 7.0PF D		
C43			CC73FCH1H1R5C	CHIP C 1.5PF C		
C44			CC73FCH1H070D	CHIP C 7.0PF D		
C45			CC73FCH1H1R5C	CHIP C 1.5PF C		

## VC-20 (VHF CONVERTER)

× New Parts

Parts without Parts No. are not supplied.

Les articles non mentionnés dans le Parts No. ne sont pas fournis.

Telle ohne Parts No. werden nicht geliefert.

Ref. No. 参照番号	Address 位置	New Parts 新	Parts No. 部品番号	Description 部品名 / 規格	Desti- nation 仕向	Re- marks 備考
C46			CC73FCH1H030C	CHIP C 3.0PF C		
C47 -49			CK73FB1H103K	CHIP C 0.010UF K		
C50			CC73FCH1H100D	CHIP C 10PF D		
C51			CC73FCH1H020C	CHIP C 2.0PF C		
C52			CC73FCH1H100D	CHIP C 10PF D		
C53 -55			CK73FB1H103K	CHIP C 0.010UF K		
C56			CC73FCH1H090D	CHIP C 9.0PF D		
C57			CC73FCH1H020C	CHIP C 2.0PF C		
C58			CC73FCH1H100D	CHIP C 10PF D		
C59			CC73FCH1H020C	CHIP C 2.0PF C		
C60			CC73FCH1H060D	CHIP C 6.0PF D		
C61 +62			CK73FB1H103K	CHIP C 0.010UF K		
C63			CC73FCH1H560J	CHIP C 56PF J		
C64 -69			CK73FB1H103K	CHIP C 0.010UF K		
C71 -77			CK73FB1H103K	CHIP C 0.010UF K		
C78			CC45SL2H030C	CERAMIC 3.0PF C		
C79			CC45SL1H470J	CERAMIC 47PF J		
C80			CC73FCH1H470J	CHIP C 47PF J		
C100-103			CK73FB1H103K	CHIP C 0.010UF K		
C105			CC45CH1H560J	CERAMIC 56PF J		
C106			CC73FCH1H180J	CHIP C 18PF J		
C107,108			CK73FB1H103K	CHIP C 0.010UF K		
C109			CC73FCH1H100D	CHIP C 10PF D		
C110-115			CK73FB1H103K	CHIP C 0.010UF K		
C116			CC73FCH1H220J	CHIP C 22PF J		
C117			CC73FCH1H180J	CHIP C 18PF J		
C118			CS15E1E010M	TANTAL 1.0UF 25WV		
C119-123			CK73FB1H103K	CHIP C 0.010UF K		
C124-126			CC73FCH1H470J	CHIP C 47PF J		
C127-129			CK73FB1H103K	CHIP C 0.010UF K		
C131			CK73FB1H103K	CHIP C 0.010UF K		
C132			C91-1074-05	FILM 0.33UF J		
C133			CE04EW1A470M	ELECTRO 47UF 10WV		
C134			CD92M1H104K	MYLAR 0.10UF K		
C135			CK73FB1H103K	CHIP C 0.010UF K		
C136			CE04EW1A470M	ELECTRO 47UF 10WV		
C137			CC73FCH1H470J	CHIP C 47PF J		
C138			CK73FB1H103K	CHIP C 0.010UF K		
C145			CK73FB1H103K	CHIP C 0.010UF K		
C146			CE04EW1A470M	ELECTRO 47UF 10WV		
C147			CK73FB1H103K	CHIP C 0.010UF K		
C148			CC73FRH1H180J	CHIP C 18PF J		
C149			CC73FRH1H060D	CHIP C 6.0PF D		
C150			CC73FCH1H020C	CHIP C 2.0PF C		
C151			CK73FB1H103K	CHIP C 0.010UF K		
C152			CC73FRH1H100D	CHIP C 10PF D		
C153			CK73FB1H103K	CHIP C 0.010UF K		
C154			CC73FSL1H101J	CHIP C 100PF J		
C155			CC73FRH1H150J	CHIP C 15PF J		
C156			CC73FRH1H080D	CHIP C 8.0PF D		
C157			CC73FCH1H020C	CHIP C 2.0PF C		
C158			CK73FB1H103K	CHIP C 0.010UF K		
C159			CC73FRH1H100D	CHIP C 10PF D		
C160			CK73FB1H103K	CHIP C 0.010UF K		
C161			CC73FSL1H101J	CHIP C 100PF J		

E: Scandinavia & Europe H: Audio Club K: USA P: Canada W: Europe

A: Saudi Arabia T: England U: PX (Far East, Hawaii)

▲ indicates safety critical components.

# -5000

## VC-20 (VHF CONVERTER)

× New Parts

Parts without Parts No. are not supplied.

Les articles non mentionnés dans le Parts No. ne sont pas fournis.

Teile ohne Parts No. werden nicht geliefert.

Ref. No. 参照番号	Address 位置	New Parts 新	Parts No. 部品番号	Description 部品名 / 規格	Desti- nation 仕 向	Re- marks 備考
C162			CC73FRH1H270J	CHIP C 27PF J		
C163			CC73FRH1H070D	CHIP C 7.0PF D		
C164			CC73FCH1H020C	CHIP C 2.0PF C		
C165			CK73FB1H103K	CHIP C 0.010UF K		
C166			CC73FRH1H100D	CHIP C 10PF D		
C167			CK73FB1H103K	CHIP C 0.010UF K		
C168			CC73FSL1H101J	CHIP C 100PF J		
C169			CC73FRH1H390J	CHIP C 39PF J		
C170			CC73FRH1H040C	CHIP C 4.0PF C		
C171			CC73FCH1H010C	CHIP C 1.0PF C		
C172			CK73FB1H103K	CHIP C 0.010UF K		
C173			CC73FRH1H100D	CHIP C 10PF D		
C174			CK73FB1H103K	CHIP C 0.010UF K		
C175			CC73FCH1H050C	CHIP C 5.0PF C		
C177			CK73FB1H103K	CHIP C 0.010UF K		
C178			CC73FCH1H090D	CHIP C 9.0PF D		
C179			CC73FCH1H680J	CHIP C 68PF J		
C180			CC73FCH1H120J	CHIP C 12PF J		
C181			CC73FCH1H180J	CHIP C 18PF J		
C182			CC73FCH1H470J	CHIP C 47PF J		
C185			CC73FCH1H100D	CHIP C 10PF D		
C186			CC73FCH1H050C	CHIP C 5.0PF C		
C187,188			CK73FB1H103K	CHIP C 0.010UF K		
C190			CE04EW1A470M	ELECTRØ 47UF 10WV		
C191			CK73FB1H103K	CHIP C 0.010UF K		
C192			CE04EW1A470M	ELECTRØ 47UF 10WV		
-			E04-0164-05	RF COAXIAL CABLE RECEPTACLE		
-			E29-0440-14	TERMINAL (GND)		
-		*	E33-1780-00	FINISHED WIRE SET(8P)		
CN1			E40-0273-05	PIN CONNECTØR (2P)		
CN2			E40-0274-05	PIN CONNECTØR (2P)		
CN3			E40-0774-05	PIN CONNECTØR (7P)L		
CN4			E40-0874-05	PIN CONNECTØR (8P)L		
-		*	F10-1348-04	SHIELDING PLATE(VCO)LOWER		
-		*	F11-1049-03	SHIELDING COVER(FRAME)		
-		*	F11-1050-03	SHIELDING COVER(FRAME)		
-		*	F11-1051-04	SHIELDING COVER(VCO CASE)		
-			G02-0518-04	FLAT SPRING		
L1			L33-0025-05	CHØKE COIL		
L2 -4			L40-1001-14	SMALL FIXED INDUCTØR(10UH)		
L5			L40-1092-14	SMALL FIXED INDUCTØR(1UH)		
L6 -12			L40-1001-14	SMALL FIXED INDUCTØR(10UH)		
L100-101			L34-1163-05	COIL		
L102			L40-1001-14	SMALL FIXED INDUCTØR(10UH)		
L103			L40-4791-14	SMALL FIXED INDUCTØR(4.7UH)		
L104			L40-1092-14	SMALL FIXED INDUCTØR(1UH)		
L105			L40-4791-14	SMALL FIXED INDUCTØR(4.7UH)		
L106			L40-1092-14	SMALL FIXED INDUCTØR(1UH)		
L107			L40-4791-14	SMALL FIXED INDUCTØR(4.7UH)		
L108			L40-1092-14	SMALL FIXED INDUCTØR(1UH)		
L109			L40-4791-14	SMALL FIXED INDUCTØR(4.7UH)		
L110			L40-1092-14	SMALL FIXED INDUCTØR(1UH)		
L111			L40-1001-14	SMALL FIXED INDUCTØR(10UH)		

E: Scandinavia & Europe H: Audio Club K: USA P: Canada W: Europe

A: Saudi Arabia T: England U: PX(Far East Hawaii)

## VC-20 (VHF CONVERTER)

\* New Parts

Parts without Parts No. are not supplied.

Les articles non mentionnés dans le Parts No. ne sont pas fournis.

Teile ohne Parts No. werden nicht geliefert.

Ref. No. 参照番号	Address 位置	New Parts 新	Parts No. 部品番号	Description 部品名 / 規格	Desti- nation 仕 向	Re- marks 備考
L112-114			L34-1164-05	COIL		
L115-121			L40-1001-14	SMALL FIXED INDUCTOR(10UH)		
L122			L40-1001-13	SMALL FIXED INDUCTOR(10UH)		
L123			L34-1163-05	COIL		
L124-126			L92-0110-05	FERRITE CORE		
L127			L40-1092-14	SMALL FIXED INDUCTOR(1UH)		
T1		*	L34-4030-05	COIL		
T2			L34-2175-05	COIL		
T3			L34-2174-05	COIL		
T4 .5			L34-2175-05	COIL		
T6		*	L34-4028-05	COIL		
T7			L34-2169-05	COIL		
T8			L34-2168-05	COIL		
T9 .10			L34-2169-05	COIL		
T11		*	L34-4028-05	COIL		
T12			L34-2172-05	COIL		
T13			L34-2171-05	COIL		
T14 .15			L34-2172-05	COIL		
T16		*	L34-4028-05	COIL		
T17			L34-2172-05	COIL		
T18			L34-2171-05	COIL		
T19 .20			L34-2172-05	COIL		
T21			L34-2161-15	COIL		
T22			L19-0350-05	BALUN TRANSFORMER		
T23		*	L34-4029-05	COIL		
T24			L19-0346-05	BALUN TRANSFORMER		
T100		*	L34-4031-05	COIL		
T101		*	L34-4032-05	COIL		
T102			L19-0350-05	BALUN TRANSFORMER		
T104			L19-0348-05	BALUN TRANSFORMER		
T105		*	L34-4033-05	COIL		
T106		*	L34-4034-05	COIL		
T107		*	L34-4035-05	COIL		
T108		*	L34-4036-05	COIL		
-			N35-2604-41	BIND HEAD MACHINE SCREW(CASE)		
-			N87-2606-46	BRAZIER HEAD TAPTITE SCREW		
-			N87-3010-41	BRAZIER HEAD TAPTITE SCREW(ANT)		
R1			RK73FB2A101J	CHIP R 100 J 1/10W		
R2			RK73FB2A750J	CHIP R 75 J 1/10W		
R3			RK73FB2A471J	CHIP R 470 J 1/10W		
R4			RK73FB2A560J	CHIP R 56 J 1/10W		
R7			RK73FB2A473J	CHIP R 47K J 1/10W		
R8			RK73FB2A104J	CHIP R 100K J 1/10W		
R9			RK73FB2A330J	CHIP R 33 J 1/10W		
R10 .11			RK73FB2A101J	CHIP R 100 J 1/10W		
R12 .13			RK73FB2A561J	CHIP R 560 J 1/10W		
R14			RK73FB2A101J	CHIP R 100 J 1/10W		
R16			RK73FB2A473J	CHIP R 47K J 1/10W		
R17			RK73FB2A104J	CHIP R 100K J 1/10W		
R18			RK73FB2A330J	CHIP R 33 J 1/10W		
R19 .20			RK73FB2A101J	CHIP R 100 J 1/10W		
R21			RK73FB2A821J	CHIP R 820 J 1/10W		
R22			RK73FB2A102J	CHIP R 1.0K J 1/10W		
R23			RK73FB2A101J	CHIP R 100 J 1/10W		

# R-5000

## VC-20 (VHF CONVERTER)

× New Parts

Parts without Parts No. are not supplied.

Les articles non mentionnés dans le Parts No. ne sont pas fournis.

Telle ohne Parts No. werden nicht geliefert.

Ref. No. 参照番号	Address 位置	New Parts 新	Parts No. 部品番号	Description 部品名 / 規格	Desti- nation 仕向	Re- marks 備考
R25			RK73FB2A473J	CHIP R 47K J 1/10W		
R26			RK73FB2A104J	CHIP R 100K J 1/10W		
R27			RK73FB2A330J	CHIP R 33 J 1/10W		
R28 ,29			RK73FB2A101J	CHIP R 100 J 1/10W		
R30			RK73FB2A561J	CHIP R 560 J 1/10W		
R31			RK73FB2A821J	CHIP R 820 J 1/10W		
R32			RK73FB2A101J	CHIP R 100 J 1/10W		
R34			RK73FB2A473J	CHIP R 47K J 1/10W		
R35			RK73FB2A104J	CHIP R 100K J 1/10W		
R36			RK73FB2A330J	CHIP R 33 J 1/10W		
R37 ,38			RK73FB2A101J	CHIP R 100 J 1/10W		
R39			RK73FB2A561J	CHIP R 560 J 1/10W		
R40			RK73FB2A102J	CHIP R 1.0K J 1/10W		
R41			RK73FB2A101J	CHIP R 100 J 1/10W		
R42			RK73FB2A271J	CHIP R 270 J 1/10W		
R43 -46			RK73FB2A220J	CHIP R 22 J 1/10W		
R47			RK73FB2A273J	CHIP R 27K J 1/10W		
R48 ,49			RK73FB2A104J	CHIP R 100K J 1/10W		
R50			RK73FB2A333J	CHIP R 33K J 1/10W		
R51 ,52			RK73FB2A101J	CHIP R 100 J 1/10W		
R53			RK73FB2A333J	CHIP R 33K J 1/10W		
R54			RK73FB2A560J	CHIP R 56 J 1/10W		
R55			RK73FB2A221J	CHIP R 220 J 1/10W		
R56			RK73FB2A681J	CHIP R 680 J 1/10W		
R57			RK73FB2A330J	CHIP R 33 J 1/10W		
R58			RK73FB2A2R2J	CHIP R 2.2 J 1/10W		
R59			RK73FB2A560J	CHIP R 56 J 1/10W		
R60			RK73FB2A220J	CHIP R 22 J 1/10W		
R63 ,64			RK73FB2A471J	CHIP R 470 J 1/10W		
R65			RK73FB2A680J	CHIP R 68 J 1/10W		
R100			RK73FB2A560J	CHIP R 56 J 1/10W		
R101			RK73FB2A103J	CHIP R 10K J 1/10W		
R102			RK73FB2A393J	CHIP R 39K J 1/10W		
R103			RK73FB2A122J	CHIP R 1.2K J 1/10W		
R104			RK73FB2A101J	CHIP R 100 J 1/10W		
R105			RK73FB2A472J	CHIP R 4.7K J 1/10W		
R106			RK73FB2A682J	CHIP R 6.8K J 1/10W		
R107			RK73FB2A470J	CHIP R 47 J 1/10W		
R108			RK73FB2A101J	CHIP R 100 J 1/10W		
R109			RK73FB2A151J	CHIP R 150 J 1/10W		
R110-113			RK73FB2A330J	CHIP R 33 J 1/10W		
R114			RK73FB2A333J	CHIP R 33K J 1/10W		
R115			RK73FB2A104J	CHIP R 100K J 1/10W		
R116			RK73FB2A105J	CHIP R 1.0M J 1/10W		
R118			RK73FB2A101J	CHIP R 100 J 1/10W		
R119			RK73FB2A221J	CHIP R 220 J 1/10W		
R120			RK73FB2A182J	CHIP R 1.8K J 1/10W		
R121			RK73FB2A222J	CHIP R 2.2K J 1/10W		
R122			RK73FB2A153J	CHIP R 15K J 1/10W		
R123			RK73FB2A2R2J	CHIP R 2.2 J 1/10W		
R124			RK73FB2A101J	CHIP R 100 J 1/10W		
R125			RK73FB2A2R2J	CHIP R 2.2 J 1/10W		
R126			RK73FB2A472J	CHIP R 4.7K J 1/10W		
R127			RK73FB2A223J	CHIP R 22K J 1/10W		
R128,129			RK73FB2A221J	CHIP R 220 J 1/10W		

## VC-20 (VHF CONVERTER)

\* New Parts  
 Parts without Parts No. are not supplied.  
 Les articles non mentionnés dans le Parts No. ne sont pas fournis.  
 Teile ohne Parts No. werden nicht geliefert.

Ref. No. 参照番号	Address 位置	New Parts 新	Parts No. 部品番号	Description 部品名 / 規格	Desti- nation 仕 向	Re- marks 備考
R131			RK73FB2A152J	CHIP R 1.5K J 1/10W		
R132			RK73FB2A224J	CHIP R 220K J 1/10W		
R133			RK73FB2A560J	CHIP R 56 J 1/10W		
R136			RK73FB2A332J	CHIP R 3.3K J 1/10W		
R137			RK73FB2A821J	CHIP R 820 J 1/10W		
R138			RK73FB2A153J	CHIP R 15K J 1/10W		
R139			RK73FB2A331J	CHIP R 330 J 1/10W		
R140, 141			RK73FB2A103J	CHIP R 10K J 1/10W		
R142			RK73FB2A105J	CHIP R 1.0M J 1/10W		
R150, 151			RK73FB2A105J	CHIP R 1.0M J 1/10W		
R152			RK73FB2A331J	CHIP R 330 J 1/10W		
R154, 155			RK73FB2A105J	CHIP R 1.0M J 1/10W		
R156			RK73FB2A331J	CHIP R 330 J 1/10W		
R158, 159			RK73FB2A105J	CHIP R 1.0M J 1/10W		
R160			RK73FB2A331J	CHIP R 330 J 1/10W		
R162, 163			RK73FB2A105J	CHIP R 1.0M J 1/10W		
R164			RK73FB2A331J	CHIP R 330 J 1/10W		
R165			RK73FB2A680J	CHIP R 68 J 1/10W		
R166			RK73FB2A472J	CHIP R 4.7K J 1/10W		
R167			RK73FB2A682J	CHIP R 6.8K J 1/10W		
R168			RK73FB2A220J	CHIP R 22 J 1/10W		
R169			RK73FB2A101J	CHIP R 100 J 1/10W		
R170			RK73FB2A560J	CHIP R 56 J 1/10W		
R171			RK73FB2A221J	CHIP R 220 J 1/10W		
R172			RK73FB2A472J	CHIP R 4.7K J 1/10W		
R173			RK73FB2A682J	CHIP R 6.8K J 1/10W		
R174			RK73FB2A220J	CHIP R 22 J 1/10W		
R175, 176			RK73FB2A101J	CHIP R 100 J 1/10W		
R177, 178			RK73FB2A102J	CHIP R 1.0K J 1/10W		
R180, 181			RK73FB2A102J	CHIP R 1.0K J 1/10W		
R183, 184			RK73FB2A681J	CHIP R 680 J 1/10W		
R185, 186			RK73FB2A221J	CHIP R 220 J 1/10W		
R187-190			RK73FB2A821J	CHIP R 820 J 1/10W		
R191			R12-1066-05	TRIMMING PNT. (1K)		
VR100			R12-1069-05	TRIMMING PNT.		
VR101-104			R92-0670-05	CHIP R 0 6HM		
W20 -24			R92-0670-05	CHIP R 0 6HM		
W123-145			SS1-1428-05	RELAY (DC9V)		
RL1 ,2			DAN202(K)	CHIP DIODE		
D1 -3			1S2588	DIODE		
D4 -7			MA858	DIODE		
D8 -11			MTZ7. 5JA	ZENER DIODE		
D100			1SV153	VARI-CAP DIODE		
D101, 102			MA858	DIODE		
D103			1SV153	VARI-CAP DIODE		
D104, 105			MA858	DIODE		
D106			1SV153	VARI-CAP DIODE		
D107, 108			MA858	DIODE		
D109			1SV153	VARI-CAP DIODE		
D110			MA858	DIODE		
D112			MTZ3. 3JA	ZENER DIODE (3.3V)		
D113			DAN202(K)	CHIP DIODE		
D114, 115			DAN401	DIODE		
D116						

E: Scandinavia & Europe H: Audio Club K: USA P: Canada W: Europe

A: Saudi Arabia T: England U: PX(Far East, Hawaii)

X: Australia M: Other Areas

⚠ indicates safety critical components.

# R-5000

## VC-20 (VHF CONVERTER)

× New Parts

Parts without Parts No. are not supplied.

Les articles non mentionnés dans le Parts No. ne sont pas fournis.

Telle ohne Parts No. werden nicht geliefert.

Ref. No. 参照番号	Address 位置	New Parts 新	Parts No. 部品番号	Description 部品名 / 規格	Desti- nation 仕向	Re- marks 備考
D117			1SS133	DIODE		
D118			MTZ5.1JA	ZENER DIODE		
D119			DAN202(K)	CHIP DIODE		
IC100			HD10551	IC(PRE SCALER)		
IC101			MC145158P	IC(PLL)		
IC102			TA78L005AP	IC(VOLTAGE REGULATOR/ +5V)		
IC103			SN74LS139N	IC(DUAL 2-4 DEMULTIPLEXERS)		
IC104		*	SN74LS07N	IC(BUFFER/DRIVER GATE)		
Q1 -4			3SK184(R)	CHIP FET		
Q5 -8			2SK125-5	FET		
Q9 ,10			3SK74(L)	FET		
Q11			2SC2570A	TRANSISTOR		
Q100			2SC2570A	TRANSISTOR		
Q101			2SC2714(Y)	CHIP TRANSISTOR		
Q102,103			3SK74(L)	FET		
Q104			2SC2570A	TRANSISTOR		
Q105			DTC124EK	DIGITAL TRANSISTOR		
Q106			2SC2714(Y)	CHIP TRANSISTOR		
Q107-110			2SK192A(GR)*P	FET		
Q111,112			2SC2570A	TRANSISTOR		
Q113-117			2SB678(E,F)	TRANSISTOR		
Q118			2SC2714(Y)	CHIP TRANSISTOR		

## VC-20 (VHF CONVERTER)

### ADJUSTMENT

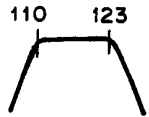
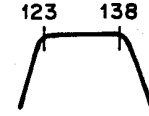
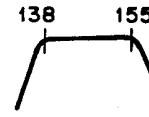
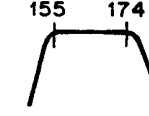
Item	Condition	Measurement			Adjustment			Specification/Remarks		
		Test equipment	Unit	Terminal	Unit	Parts	Method			
1. VCO	MODE : FM	DC V.M	PLL	TP2	PLL	T105	2.0V	±0.05V		
	1) LL BAND FREQ. : 108.000MHz						Check	3.8±0.5V		
	: 129.990MHz									
	2) L BAND FREQ. : 123.000MHz						T106	2.0V	±0.05V	
	: 137.990MHz							Check	3.7±0.5V	
	3) H BAND FREQ. : 138.000MHz						T107	2.0V	±0.05V	
: 154.990MHz		Check	3.9±0.5V							
4) HH BAND FREQ. : 155.000MHz	T108	2.0V	±0.05V							
		Check	3.9±0.5V							
2. PLL MIX	1) FREQ. : 174.000MHz	RF V.M	PLL	TP1 TPG	PLL	T100, T101 VR100 VR101	MAX.			
							MIN. MAX.			
3. RF BPF	1) Connect the Tracking generator and High impedance probe and Spectrum analyzer to ANT terminal. MODE : FM ATT : 0dB 1) LL BAND FREQ. : 108.000MHz Marker spot : 110MHz, 123MHz	Tracking generator (20dB ATT) Spectrum analyzer OSCILLO	RF	ANT TP3 TPG	RF	T1~5	Waveform perform as shown on right.	Tracking generator : Less than -30dBm		
										
								T16~ T20		
								T11~ T15		
	4) HH BAND FREQ. : 155.000MHz Marker spot : 155MHz, 174MHz			T6~ T10						
4. Sensitivity	1) FREQ. : 145.02MHz MODE : FM SSG MOD : 1kHz DEV : 5kHz output : 145.02MHz, 20dBμ	SSG AF V.M	RF R-5000	ANT EXT.SP S-meter	RF R-5000	T23	S-meter MAX. flat.	S/N more than 10dB		
	2) SSG output : 145.021MHz, -6dBμ MOD : OFF						Check	S/N More than 10dB.		

## VC-20 (VHF CONVERTER)

Item	Condition	Measurement			Adjustment			Specification/Remarks
		Test equipment	Unit	Terminal	Unit	Parts	Method	
5. Spurious	1) FREQ. : 155.388.5MHz MODE : FM SSG output : 155.388.5MHz, MOD : ON	8Ω dummy load	R- 5000	EXT.SP	R- 5000	AF VOL	0.63V	
	2) SSG MOD : OFF				VC-20 PLL	VR101 VR100	AF output MIN.	AF output less than 20dB
	3) FREQ. : 147.388.5MHz MODE : FM SSG output : 147.388.5MHz, 60dBμ MOD : ON				R- 5000	AF VOL	0.63V	
	4) SSG MOD : OFF				VC-20 PLL	VR102	AF output MIN.	AF output Less than 20dB.
	5) FREQ. : 135.388.5MHz MODE : FM SSG output : 135.388.5MHz, 60dBμ MOD : ON				R- 5000	AF VOL	0.63V	
	6) SSG MOD : OFF				VC-20 PLL	VR103	AF output MIN.	AF output less than 15dB.
	7) FREQ. : 118.388.5MHz MODE : FM SSG output : 118.388.5MHz, 60dBμ MOD : ON				R- 5000	AF VOL	0.63V	
	8) SSG MOD : OFF				VC-20 PLL	VR104	AF output MIN.	AF output less than 20dB.
6. IF trap	1) FREQ. : 123.020MHz MODE : USB SSG output : 58.112.5MHz, 80dBμ	SSG AF V,M	R- 5000	ANT connec- tor EXT.SP	RF	T21	AF output MIN.	Divider ratio is more than 80dB.

### ADJUSTING POINT

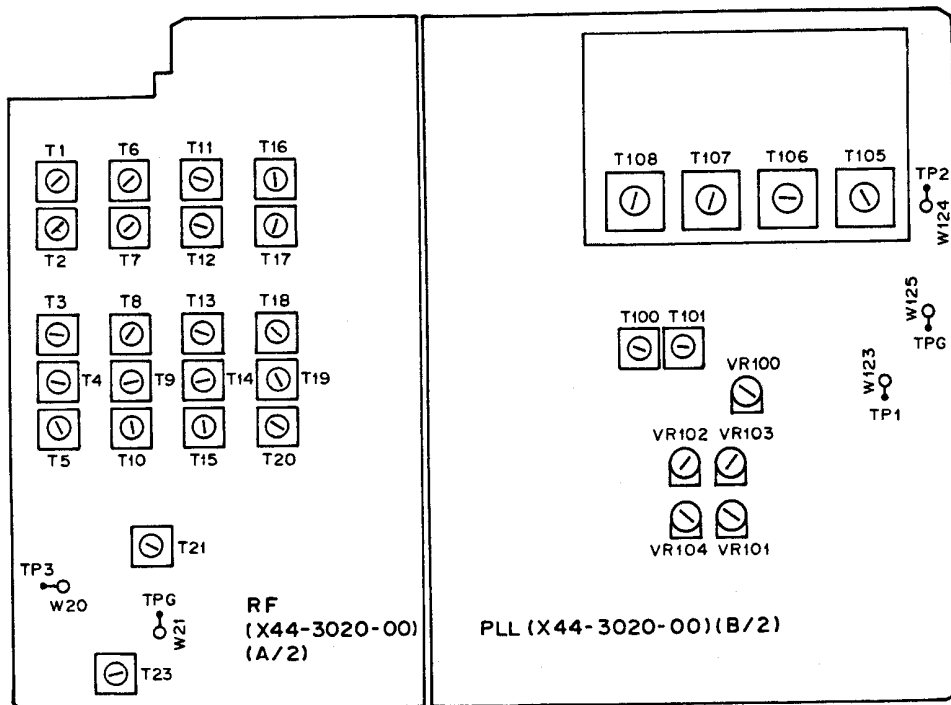

# R-5000 VC-20 (VHF CONVERTER) PC BOARD VIEWS

▼ CONVERTER UNIT (X44-3020-00) Component side view

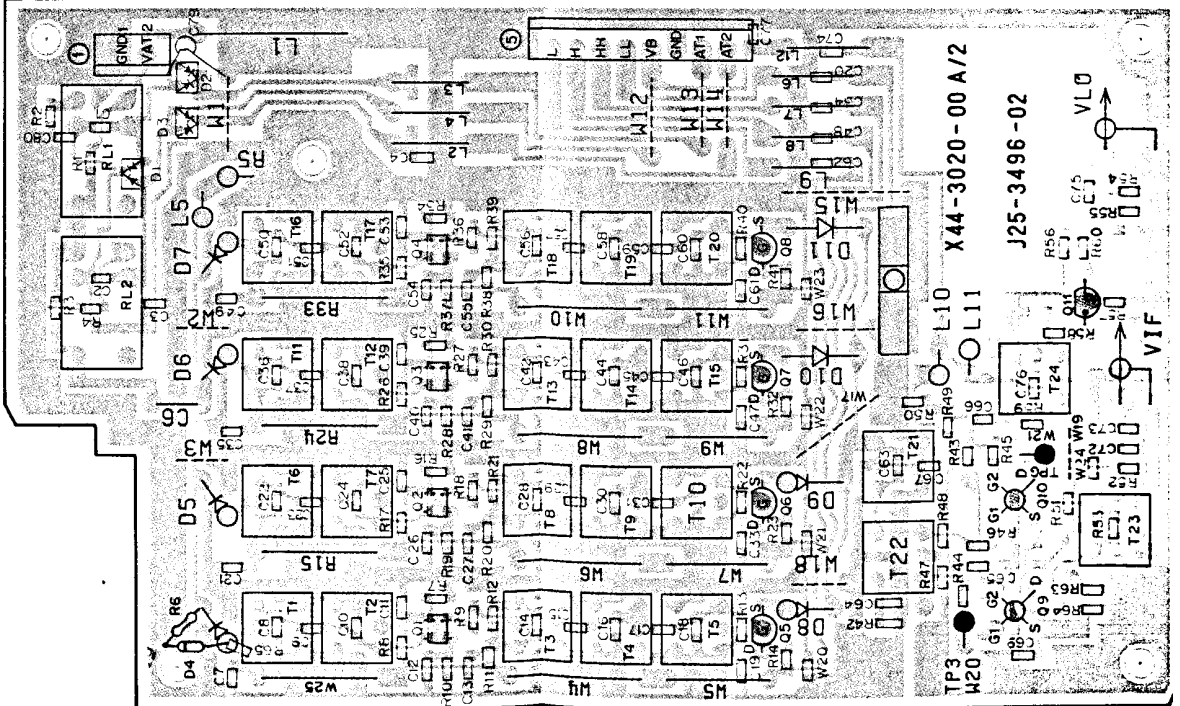
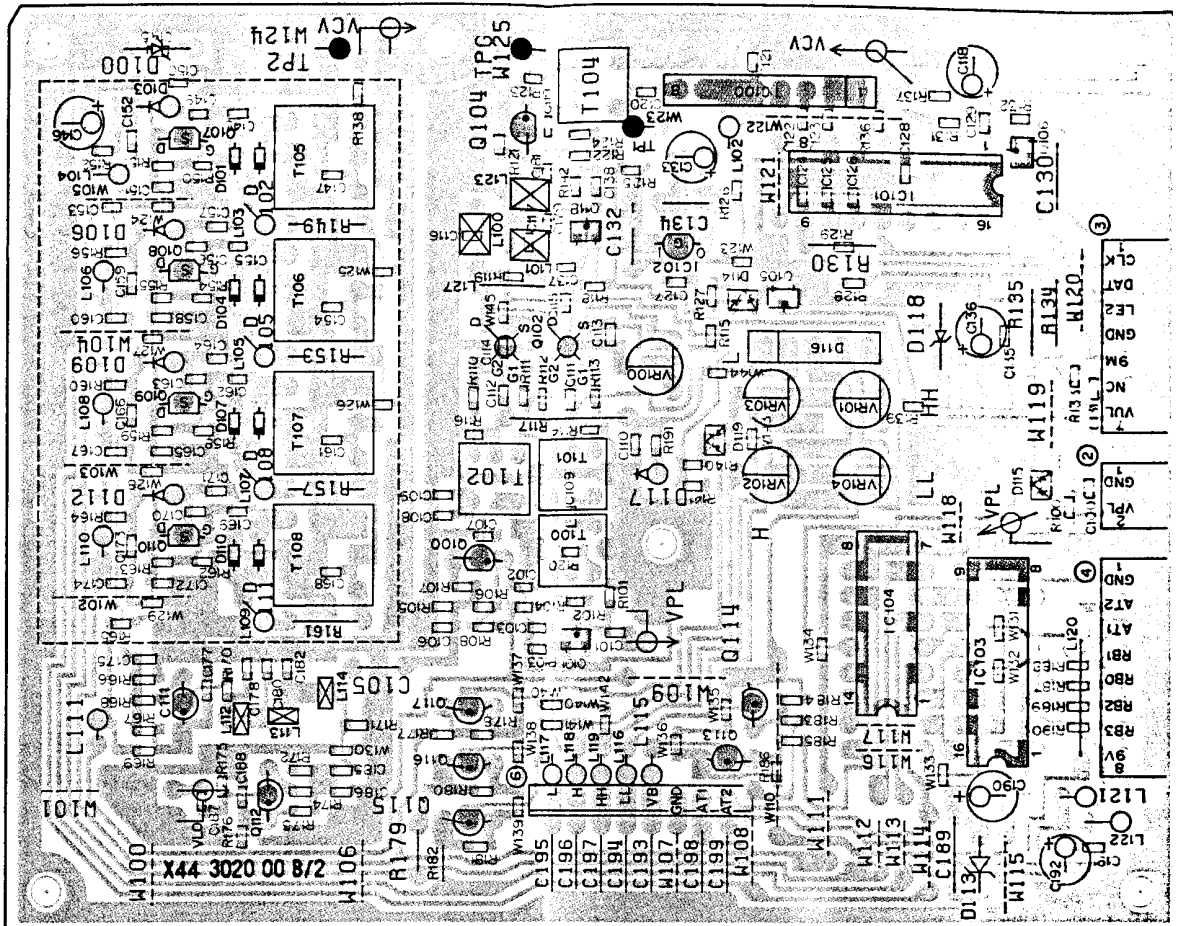



## INSTALLATION OF OPTIONS

**Voice Synthesis Unit VS-1**

When the voice synthesis unit is installed, the user does not have to look at the display to read the frequency, but can hear it spoken by a synthesized voice. A switch on the unit selects English or Japanese.

- (1) Remove the top and bottom cover of the receiver cabinet.
- (2) Space for installing the VS-1 unit is provided beside the Power unit. Insert the VS-1 unit in the shield case, making sure it is oriented correctly, and secure it with the two supplied screws.
- (3) Near the VS-1 unit are an unconnected 3-pin connector and 8-pin connector. Plug the 3-pin connector onto J01 on the VS-1 unit (the green connector), the 8-pin connector into J02.
- (4) Set switch S1 on the VS-1 unit to select English or Japanese.
- (5) When power is on, the frequency is spoken when the VOICE switch is pressed. The voice volume can be adjusted by turning VR1 on the VS-1 unit with a screwdriver.

**Warning :** Be careful not to break the wires leading to the speaker mounted on the top cover. Remove these lead wires from the speaker terminals before installing the VS-1 unit.

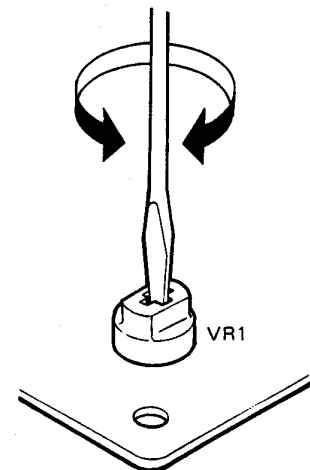
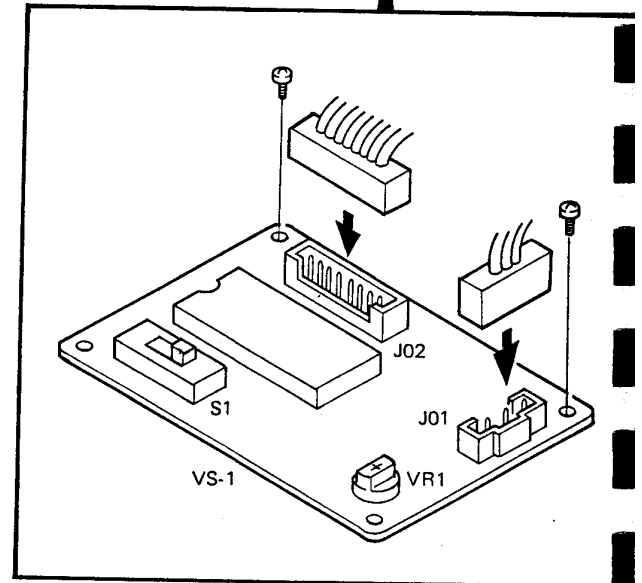
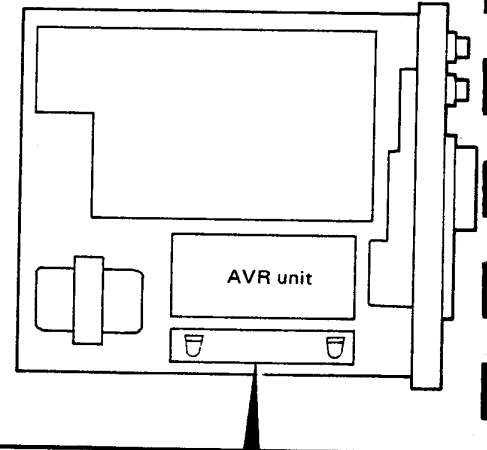

## INSTALLATION OF OPTIONS

### Crystal Filter

A selection of optional filters is available for the R-5000 series : the YK-88SN, YK-88C, YK-88CN, and YK-88A-1. To install them, remove the top cover of the receiver and follow the procedure below. Detach the speaker lead wires so that they will not be broken.

**Note :** Solder as quickly as possible, using a low-power soldering iron (15W to 30W). Be careful not to break the speaker wires when removing the IF unit.

#### 2-1. YK-88A-1

- (1) Remove the two screws holding the filter board (X48-3000-00) (B/2) to the IF unit board, and remove the filter board.
- (2) Install YK-88A-1 and secure it with the two screws.

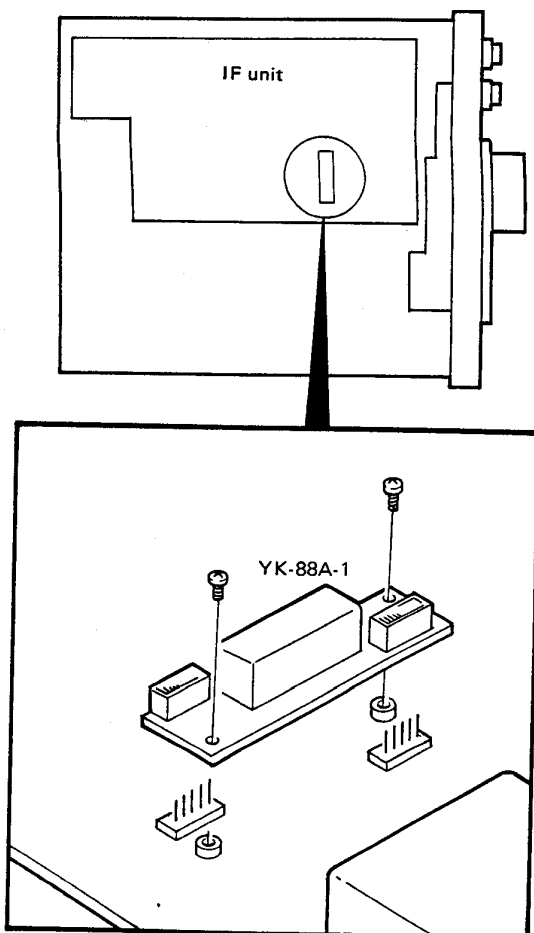

#### 2-2. YK-88SN, YK-88C, and YK-88CN

- (1) Remove the seven screws holding down the IF unit board, and lift it from the chassis.
- (2) Insert the filter into the space provided, and solder it to the foil side of the board at six points. Cut off the excess filter leads extending from the board.
- (3) Install the YK-88SN filter in the position marked SELECTIVITY M1 FILTER. Change the white filter selection jumper wire marked M1 FILTER from the NO position to the YES position.
- (4) Install the YK-88C or YK-88CN filters in the position marked SELECTIVITY N FILTER. Change the white filter selection jumper wire marked N FILTER from the NO position to the YES position.
- (5) Reattach the IF unit to the chassis in its former position with the seven screws.
- (6) Reattach the speaker wires and replace the top cover.

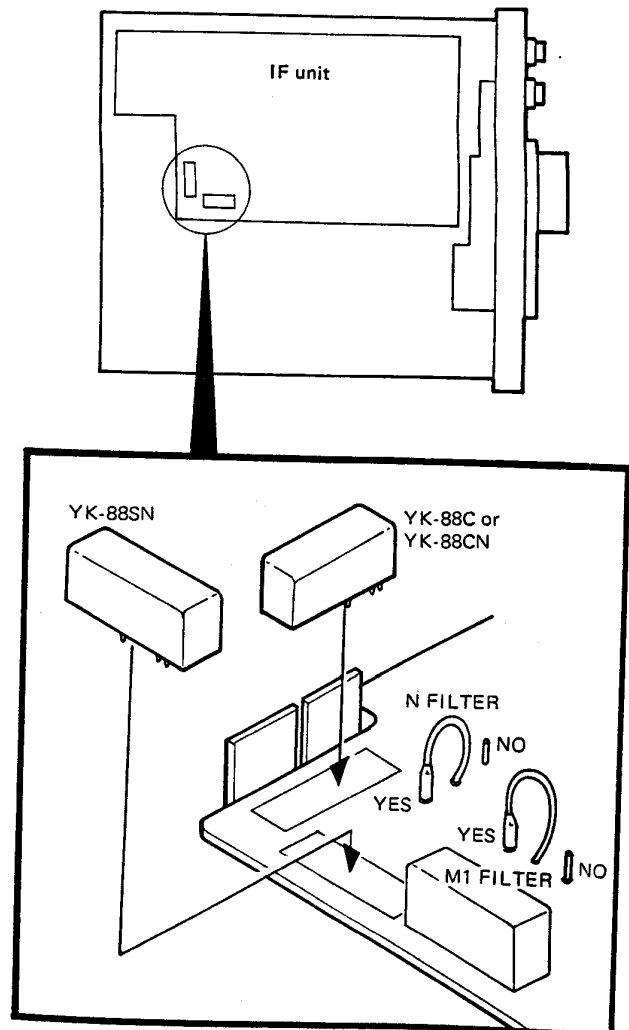

● Voltage measurement conditions  $f = 145.02\text{MHz}$ , FM mode receiving

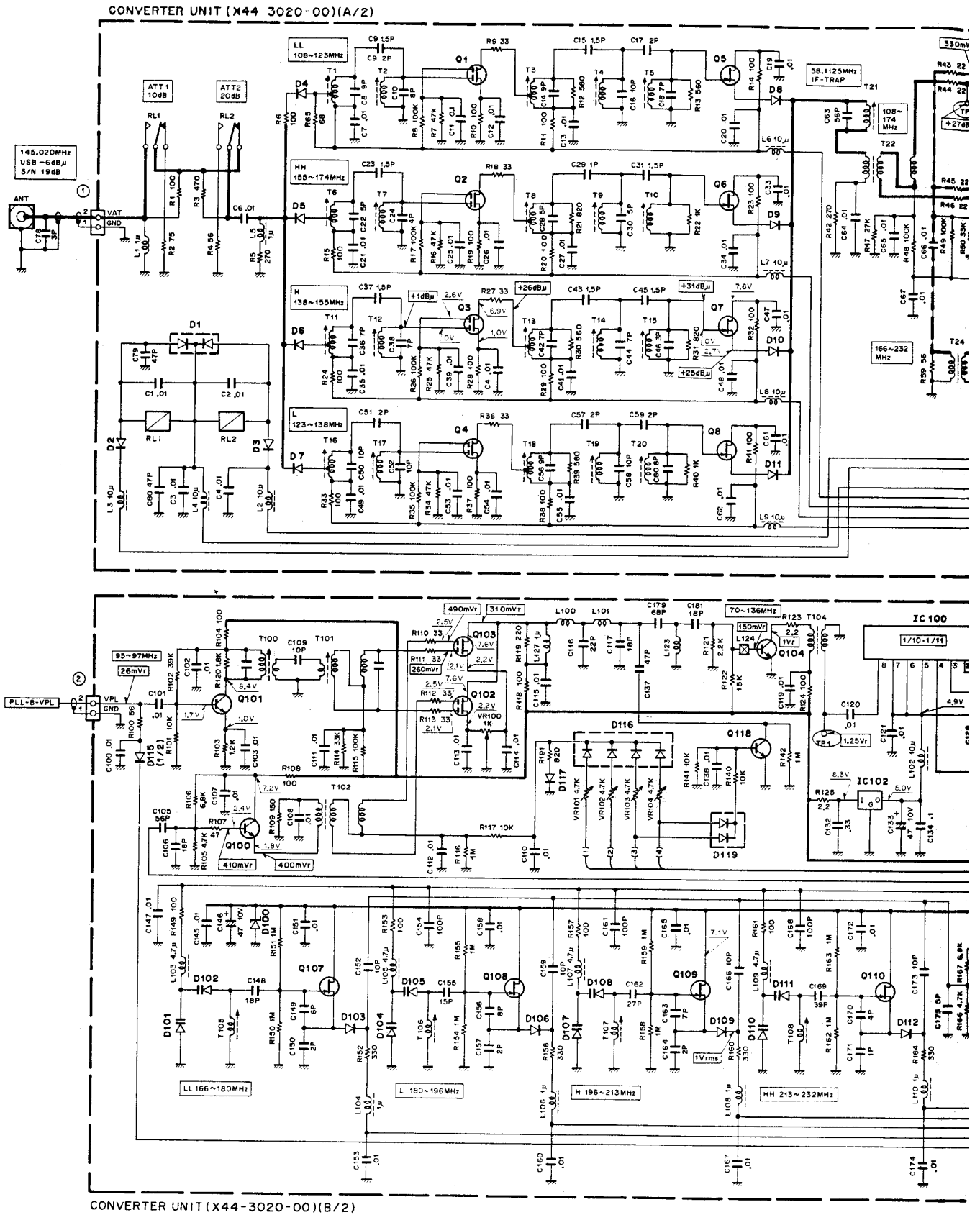

# VC-20 (VHF CONVERTER) CIRCUIT DIAGRAM R-5000

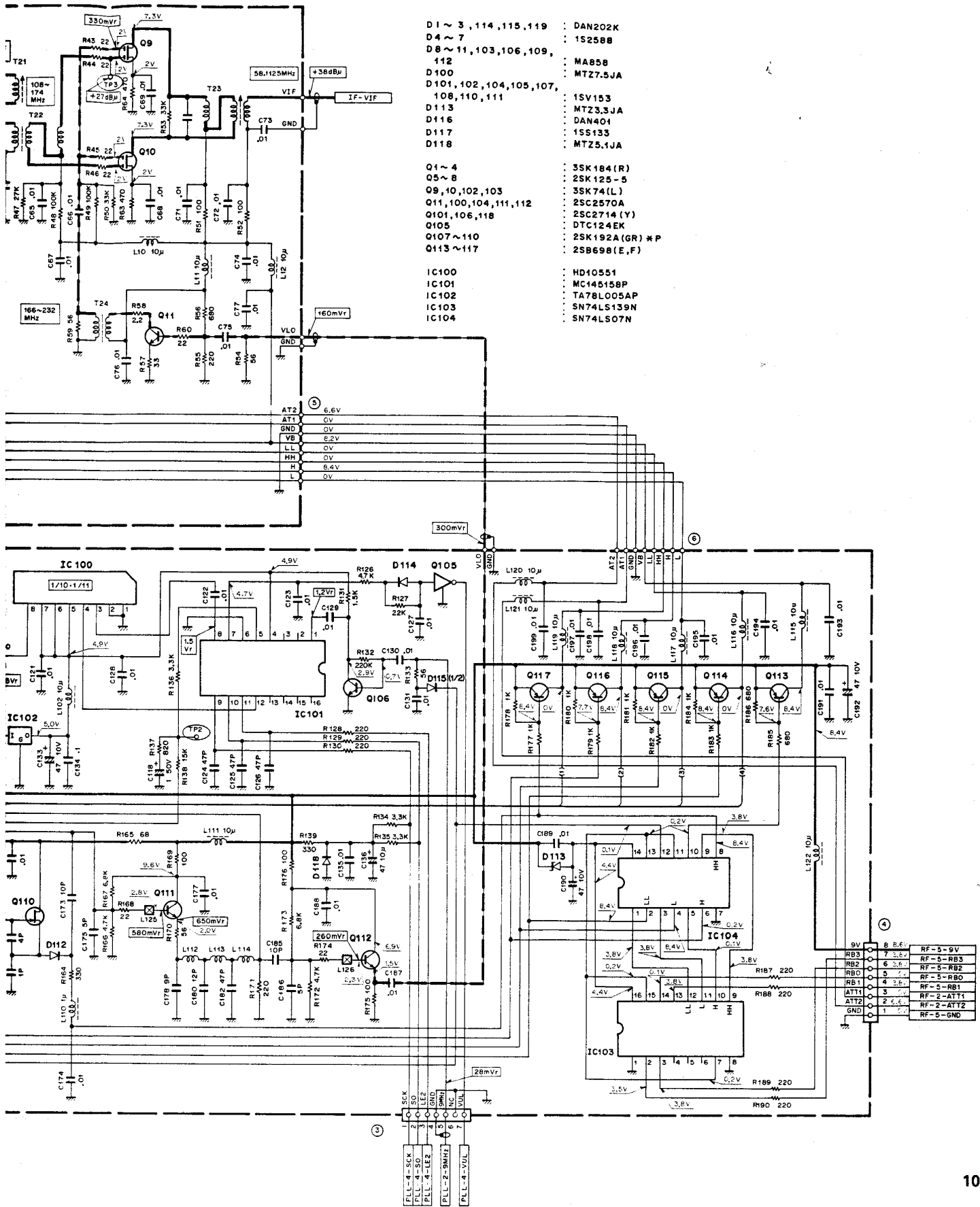

## INSTALLATION OF OPTIONS

### RS-232C Interface Chip IC-10

- (1) Remove the top and bottom covers of the receiver.
- (2) Remove the four screws at the sides of the front panel and pull the front panel forward.
- (3) Remove the five screws (two at the top and three at the bottom) holding the shield plate behind the front panel, and remove the shield plate.
- (4) Insert the IC package from the interface kit (IC54, IC55) in the socket on the board.

Make sure the IC package is inserted securely and in the right direction, and be careful not to damage any of the pins.

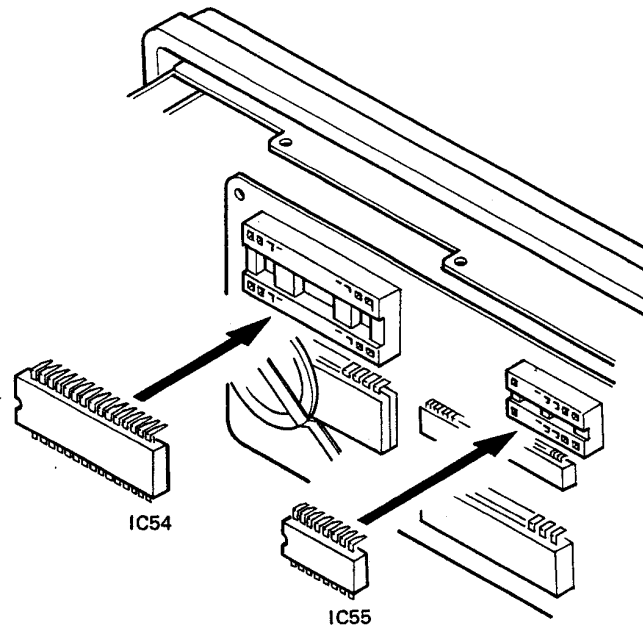

## INSTALLATION OF OPTIONS

### DC Power Cable Kit DCK-2

The DCK-2 cable kit is provided for running the R-5000 set from a DC power supply. The installation procedure is as follows :

- (1) Remove the top cover of the case.
- (2) Remove the blind plate from the rear panel.
- (3) Mount the DC connector in the hole provided for it on the rear panel, using two screws.
- (4) Pass the cable with the 3-pin connector through the two lead holders and plug the connector onto location ⑤ on the AVR unit. The unused pin must be closer to the transformer.
- (5) Use the DC cables to connect the R-5000 to the DC power supply.

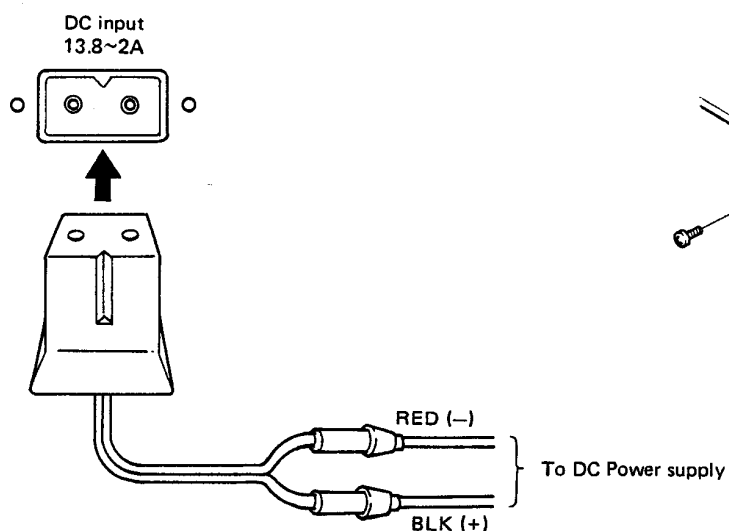
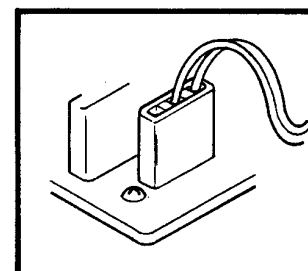
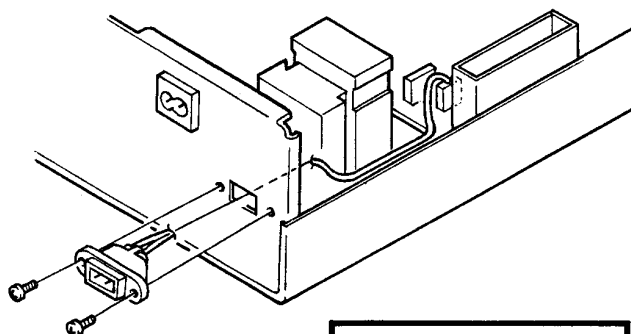
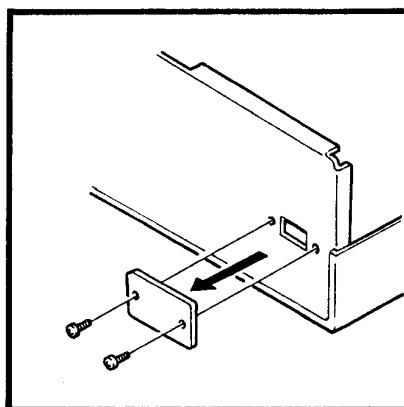

## INSTALLATION OF OPTIONS

### VHF Converter VC-20

The VC-20 VHF converter enables the R-5000 to receive the VHF band from 108MHz to 174MHz. The installation procedure is as follows.

- (1) Remove the top cover of the receiver.
- (2) Attach the two mounting brackets to the chassis with one screw (Bind screw M3 x 4) each.
- (3) Insert the VC-20 from the rear with the antenna connector facing the rear, and attach the VC-20 to the rear panel with four screws (Tapping screw M3 x 6).
- (4) Attach the VC-20 to the two brackets with two screws (Bind screw M3 x 4).

- (5) Near the VC-20 is an unconnected 2-pin connector, a 7-pin connector, and an 8-pin connector. Plug the 2-pin connector onto location ② on the VC-20, the 7-pin connector onto location ③, and the 8-pin connector onto location ④.

- (6) Plug the coaxial cable from the VC-20 into the coaxial connector marked VIF on the IF unit.

**Warning :** Be careful not to break the speaker wires attached to the top cover. Remove these wires from the speaker terminals (speaker side) before installing the VC-20 unit. When installing the converter, be careful the wires not to be caught in the units.

The wires to the VC-20 are bound together with other wires in the IF unit. Remove the bead bands before connection.

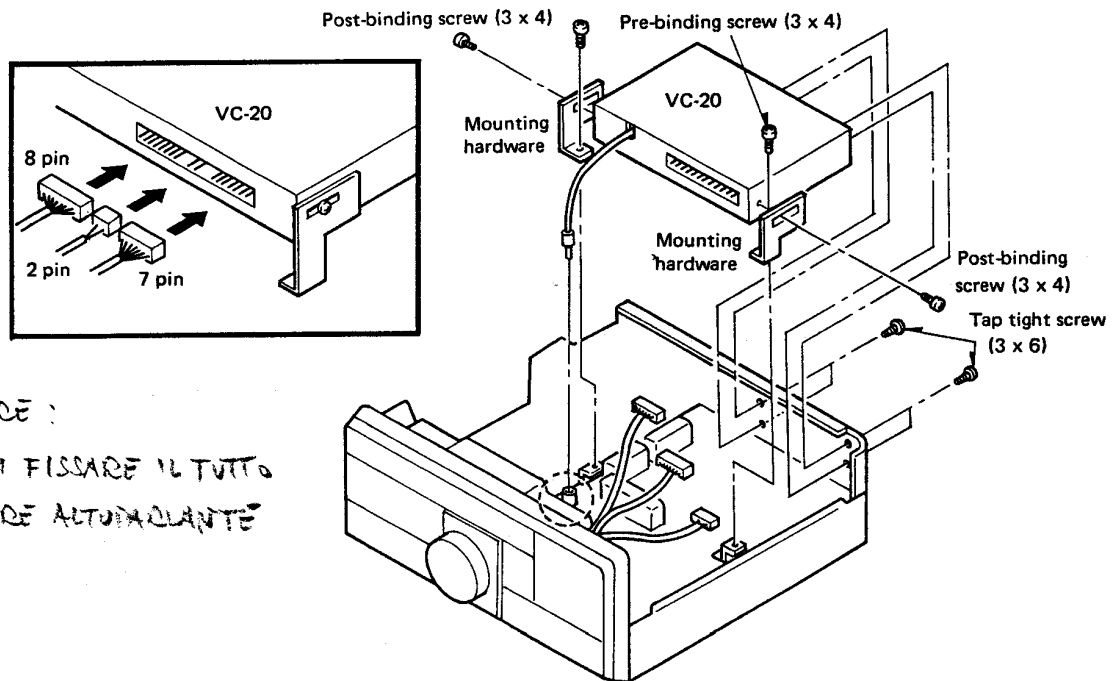

RICORDARE :  
PRIMA DI FISSARE IL TUTTO  
COLLEGARE AUTOMOLANTE

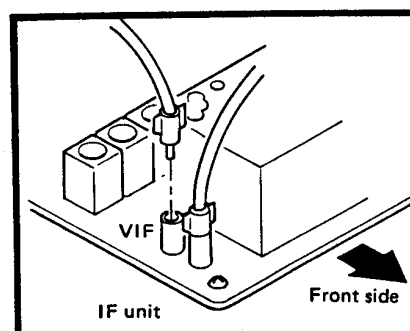

# R-5000

## SPECIFICATIONS

### <GENERAL>

#### Receive frequency range

100kHz~30MHz

#### Mode

A1 (CW), A3J (SSB), A3 (AM), F1 (FSK), F3 (FM)

#### Antenna impedance

50/500Ω

#### Power requirement

AC 100V±10%, DC 13.8V±15%

#### Power consumption

AC : 35W, DC : 2A

#### Frequency configuration

1st IF : 58.1125MHz  
 2nd IF : 8.83MHz  
 3rd IF (FM mode only) : 455kHz  
 CW, SSB, AM, FSK; Double conversion superheterodyne  
 FM; Triple conversion superheterodyne

#### Image ratio

60dB or more (100kHz~1.8MHz)  
 80dB or more (1.8MHz~30MHz)

#### IF rejection ratio

60dB or more (100kHz~1.8MHz)  
 70dB or more (1.8MHz~30MHz)

#### IF SHIFT variable range

±0.9kHz or more

#### RIT/XIT variable range

±1kHz or more

#### Audio output power

1.5W or more (with 8Ω load, 10% distortion)

#### Audio output impedance

4~16Ω (including speakers and headphones)

#### Operating temperature

-10°C~+50°C

#### Dimensions ( ) includes projection

W 270(279) x H 96(107) x D 270(307)mm

#### Weight

5.5kg (1210lbs)

### <FREQUENCY STABILITY>

#### Frequency accuracy

Within ±10 × 10<sup>-6</sup>

#### Frequency stability (RIT/XIT OFF)

Within ±10 × 10<sup>-6</sup> (-10°C~+50°C)

#### Reference oscillators frequency

18MHz

#### Sensitivity

Mode \ Range	100~150kHz	150~500kHz	500kHz~1.6MHz	1.6~30MHz
SSB, CW, FSK (S + N/N = 10dB)	2.5μV or less	1μV or less	4μV or less	0.25μV or less
AM (30% Mod. S + N/N = 10dB)	25μV or less	10μV or less	16μV or less	2μV or less
FM (12dB SINAD)	-	-	-	0.5μV or less

#### Squelch sensitivity (Threshold)

Mode \ Range	100~150kHz	150~500kHz	500kHz~1.6MHz	1.6~30MHz
SSB, CW, AM, FSK	20μV or less	10μV or less	20μV or less	2μV or less
FM	-	-	-	0.32μV or less

#### Selectivity

Mode \ Range	-6dB	-50dB	-60dB
SSB, CW, FSK	2.5kHz or more	-	5.8kHz or less
AM	4kHz or more	20kHz or more	-
FM	12kHz or more	25kHz or more	-

Note : Circuit and ratings subject to change without notice due to developments in technology.

## KENWOOD CORPORATION

Shionogi Shibuya Building, 17-5, 2-chome Shibuya, Shibuya-ku, Tokyo 150, Japan

### KENWOOD U.S.A. CORPORATION

P.O. BOX 22745, 2201 East Dominguez St., Long Beach, CA 90801-5745, U.S.A.

### KENWOOD ELECTRONICS DEUTSCHLAND GMBH

Rembrücker Str. 15, 6056 Heusenstamm, West Germany

### KENWOOD ELECTRONICS BENELUX N.V.

Mechelsesteenweg 418 B-1930 Zaventem, Belgium

### TRIO-KENWOOD FRANCE S.A.

5, Boulevard Ney, 75018 Paris, France

### KENWOOD ELECTRONICS AUSTRALIA PTY. LTD.

(INCORPORATED IN N.S.W.)

4E, Woodcock Place, Lane Cove, N.S.W. 2066, Australia

## R - 5 0 0 0 E r a t t a

Please make the following change to your R - 5 0 0 0 Instruction Manual.

### 1. Page 8, "2-2. ACCESSORIES"

The DIN connector (7-pin) (PN E07-0751-05) is not provided.

### 2. Page 26, "4-5-2. CLOCK, B. Time set "

1. Select the CLOCK for which the time is to be set.
2. Press the TIME SET switch.
3. Simultaneously press the HOUR and MINUTE keys to stop the clock.
4. Set the desired time using the HOUR and MINUTE keys.
5. Turn the TIME SET switch to OFF, the colon on the clock display starts blinking, indicating the new time.

Synchronizing your clocks to a known time standard such as WWV or JJY.

1. Set CLOCK 1 according to the instructions above.
2. Set the time of CLOCK 2 so that it is one minute ahead of the time you wish to begin.  
For example , the present time is 5:59 UTC and you want the synchronization to begin at 6:00 UTC, so you would set CLOCK 2 to read 6:00.
3. To start the clock you would turn the TIME SET switch OFF in synchronization with the tone signal generated by the appropriate time standard. This will automatically synchronize both CLOCK 1 and CLOCK 2 to the time standard.

NOTE: An error of 1 minute between the minutes displayed on CLOCK 1 and CLOCK 2 may occur if both clocks are not displaying the same number of minutes , i.e. CLOCK 1 \_\_:59:00 and CLOCK 2 \_\_:00:00 when you set CLOCK 2.

# Other ManualsLib Projects



[www.manualslib.com](http://www.manualslib.com)



[www.manualslib.de](http://www.manualslib.de)



[www.manualslib.es](http://www.manualslib.es)



[www.manualslib.fr](http://www.manualslib.fr)



[www.manualslib.nl](http://www.manualslib.nl)



[www.manualslib.mx](http://www.manualslib.mx)



[www.manualslib.tech](http://www.manualslib.tech) 30+ Languages